

SERIES EA12 Oil Submerged Valve Actuators, Two-Position

APPLICATION

For two position operation of damper, valves and other equipment which require the return to normal position upon power interruption.

SPECIFICATIONS

Application: Valve Actuators.

Shaft Rotation: CW 170° when power is applied.

Spring Return: CCW to original position when actuator is de-energized.

Rated Torque: 60 lb.-in (6.8 N-m)

Case: Die cast aluminum with two 1/2" conduit openings.

Mounting: Output shaft horizontal. Allow 6" (152mm) clearance above the actuator wiring compartment.

Dimensions: 5-3/4" high x 5-3/8" wide x 6-9/16" deep (146 mm x 136mm x 167mm).

Environment:

Ambient temperature limits: -40 to 136°F (-40 to 58°C).

Humidity: 5 to 95% R.H., non-condensing.

Locations: NEMA Type 1.

Control Circuit: Two wire.

Connections: Coded screw terminals.

Input: 70 watts running; 25 watts holding.

No load timing: 20 sec. @ 75°F (24°C). (Spring return timing with full load opposing spring approximately 60 sec.)

Auxiliary Switch: 2 FLA, 12 LRA @ 240/120 Vac; 1 FLA, 6 LRA @ 240 Vac. SPDT makes or breaks circuit at powered end of stroke. (-0008X models; see Table 1).

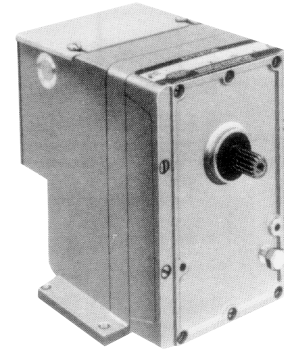

PRE-INSTALLATION

Inspection

Inspect the carton for damage. If damaged, notify the appropriate carrier immediately. Inspect the device for obvious damage. Return damaged products.

Required Installation Items

- Wiring diagram
- Mounting screws (not provided) and tools to place and fasten mounting screws
- Volt/Ohm meter

INSTALLATION

Always link the actuator to the load to allow the actuator to reach full end of travel.

CAUTION

1. Installer must be a qualified, experienced technician.
2. Disconnect power supply before installation to prevent electrical shock and equipment damage.
3. Make all connections in accordance with the wiring diagram, and in accordance with national and local electrical codes.
4. Do not exceed ratings of the device.
5. Avoid locations where excessive vibration, moisture or corrosive fumes are present. The case of the actuator is intended for use primarily to provide a degree of protection against contact with enclosed components, i.e., NEMA type 1.

Table 1. Electrical Specifications

Part Number	Power Supply		VA Run	Hold	Auxiliary Switch
	Vac	Hz			
EA12	120	60	108	42	No
EA12-00080	120	60	108	42	Yes
EA12-00003	240	60	120	39	No
EA12-00083	240	60	120	39	Yes
EA12-00005	24	60	92	32	No
EA12-00085	24	60	92	32	Yes

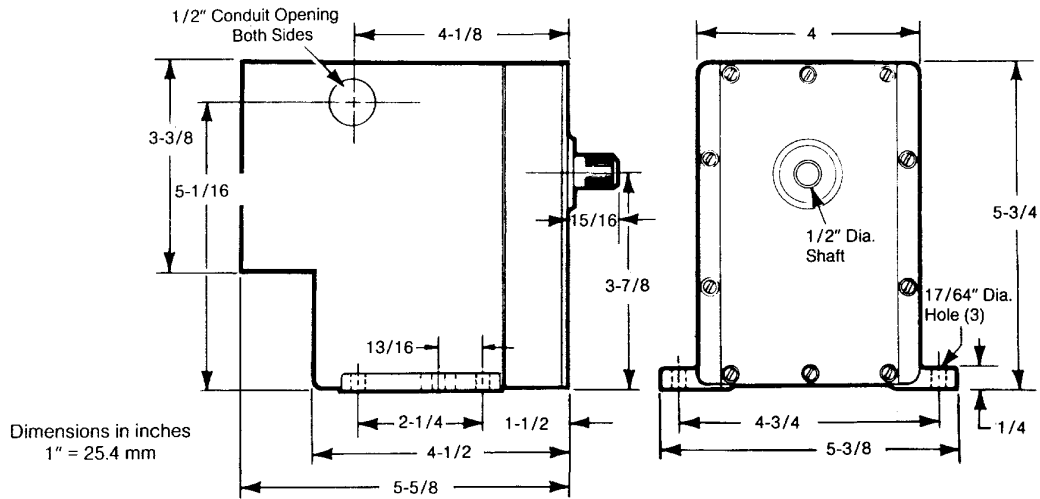

Figure 1. Mounting Dimensions

Mounting Location

Allow 6" (152 mm) clearance above the actuator wiring compartment. Locate actuator in a weather protected area. Three 17/64" mounting holes are provided in the base of the actuator (see Figure 1 for mounting dimensions). EA12 series actuators output shaft must be mounted in a horizontal position.

Wiring

Two 1/2" conduit knockouts are provided on the actuator case. See Figure 3 and Table 2 for wiring information.

Table 2. Power Wire Selection

Actuator Series	Wire Size (AWG)	Maximum Run in ft. (m) (1 run has 2 wires)
EA12 EA12-00080	14	950 (290)
	12	1580 (482)
EA12-00003 EA12-00083 EA12-00005 EA12-00085	14	44 (13)
	12	68 (21)
	10	110 (34)

Opposite each model number and wire size is the maximum 2 wire run in feet for one actuator. To determine the maximum run when multiple actuators are used, divide the number of actuators into the corresponding maximum run.

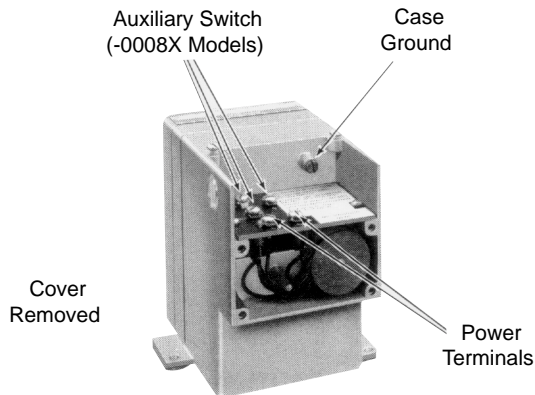
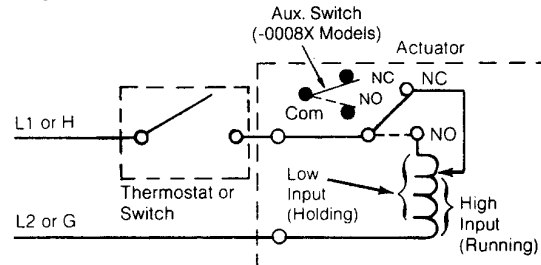

Figure 2. Terminal Locations

CAUTION

NEVER ATTEMPT TO TURN THE ACTUATOR SHAFT WITH A WRENCH OR CRANK. This will cause internal damage to the actuator.



Actuator rotates 170° CW when thermostat or switch contacts are closed. Actuator spring returns when thermostat or switch contacts are open.

Figure 3. Typical Wiring for EA12

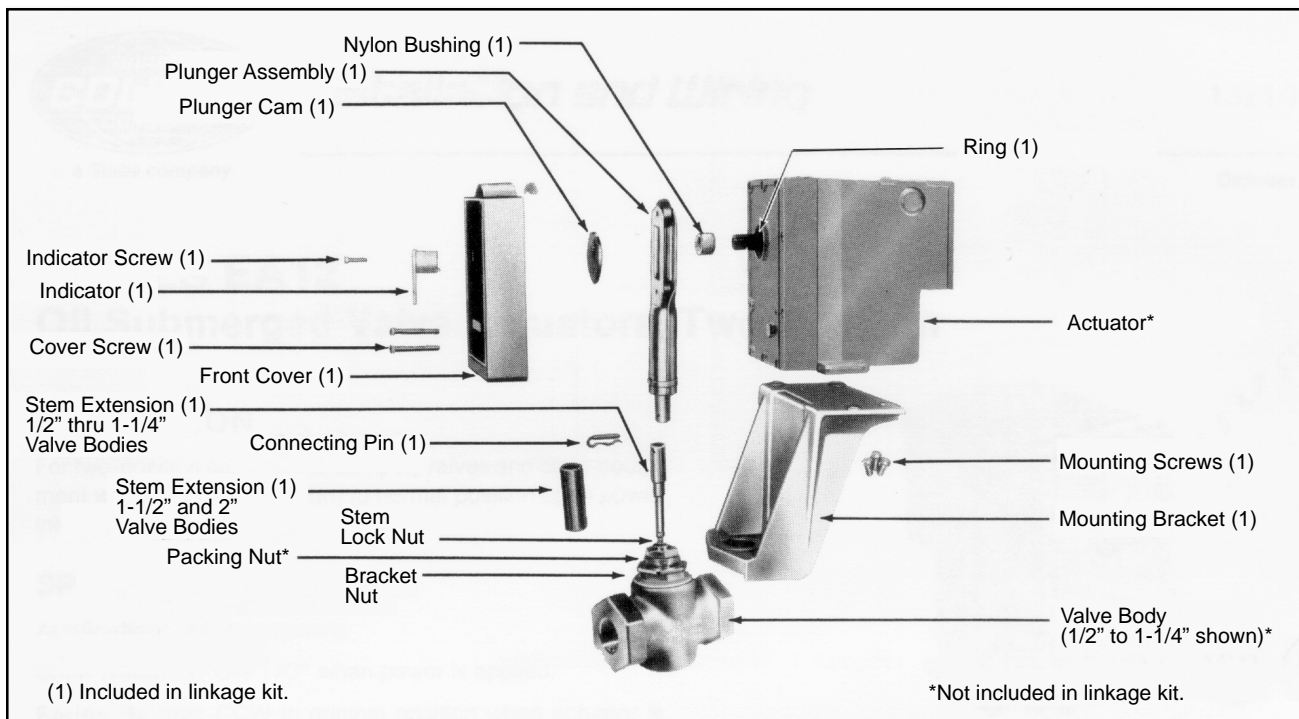

Figure 4. Typical Components for Valve Installation

VALVE INSTALLATION

Install all globe type valves maintaining proper flow direction as indicated by arrows on the valve body. Always install single-seat valves with pressure under the seat. Always install three-way mixing valves with two inlets and one outlet. Always install three-way diverting valves with one inlet and two outlets. For hot or chilled water valve applications, mount the actuator above valve body. For steam valve applications mount the actuator above the valve body at 45° from vertical.

CHECKOUT

After the entire system has been installed, the following check for proper operation can be made:

1. Make certain that the system wiring is connected and powered.
2. Be sure the controller (manual or automatic) is operating properly per system requirements.
3. When the controller (manual or automatic) energizes the actuator, the output shaft will run to the end of the stroke (170°CW).
4. When the controller (manual or automatic) de-energizes the actuator, the spring will return the output shaft to its original position.

5. The action of the auxiliary switch (-0008X models):

- C made to NC when actuator is de-energized.
- C made to NO when actuator is energized and the output shaft reaches the end of the stroke.

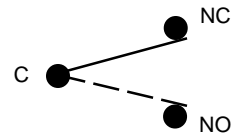

Figure 5. Auxiliary Switch (-0008X Models)

MAINTENANCE

Regular maintenance of the total system is recommended to assure sustained optimum performance.

FIELD REPAIR

None. Replace with a functional actuator.



InstruCon, Inc.
3415 Precision Drive,
Rockford, IL 61109

815-874-2000
815-874-2211 Fax

<http://www.instrucon.com/actuators>