

Wire and Accessories

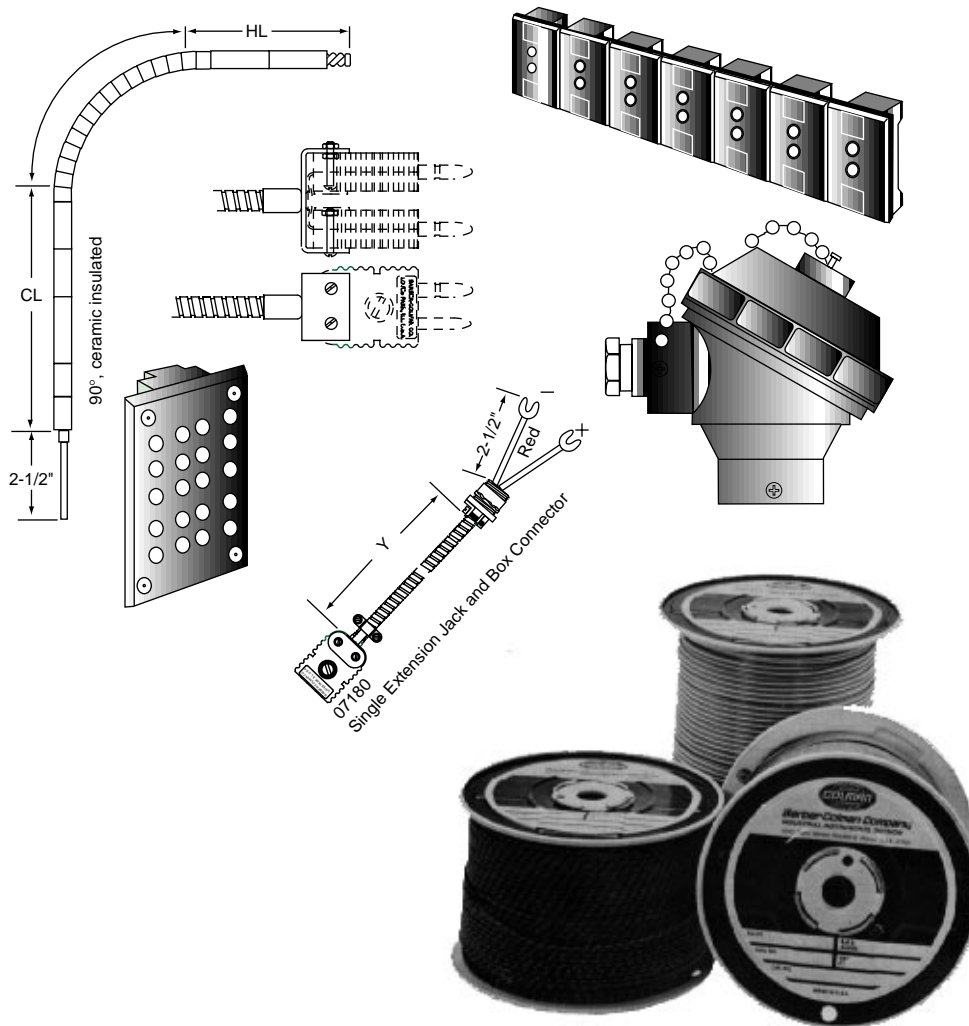

MqO Wire

BARCOPAC® Thermocouple Wire Metal Sheathed – MgO Insulated

Introduction

Each BARCOPAC® thermocouple wire is uniformly insulated with compacted magnesium oxide, and protected by a stainless steel or Inconel sheath. Bulk wire is provided without junction or terminal connections; its ends are sealed to prevent contamination.

Specifications

Sheath Thickness and AWG	Sheath o.d.	Tolerance o.d.	Wall Thickness	Nominal AWG Wire Size	
				Single	Dual
	0.040"	+0.001/-0.0005"	0.006"	33	n/a
	0.063"	±0.001"	0.009"	28*	20
	0.125"	+0.002/-0.001"	0.017"	22*	23
	0.188"	+0.002/-0.001"	0.025"	19	20
	0.250"	+0.002/-0.001"	0.033"	16	19

*AWG for types R and S is 30 for 0.063" o.d., and 26 for 0.125" o.d.

Weight	Sheath o.d.	Pounds per 100 feet	Standard Maximum Length
	0.063"	0.8	250 feet*
	0.125"	2.8	80 feet*
	0.188"	5.0	35 feet
	0.250"	12.5	30 feet

*Standard length for types R and S is 20 feet. Consult factory for longer length.

Ordering Information

Note: an alpha code in Field 2 indicates special limits; a numeric code indicates standard limits. Also, code "0" in Field 5 indicates single element; code "9" indicates dual element.

Special Limits	Model Number	Type	Elements	Sheath	Diameter
	MJ14 - 00000-000-0-00	J	single	304 SS	0.125"
	MJ15 - 00000-000-0-00	J	single	304 SS	0.187"
	MJ16 - 00000-000-0-00	J	single	304 SS	0.250"
	MJ16 - 90000-000-0-00	J	dual	304 SS	0.250"
	MJ24 - 00000-000-0-00	J	single	Inconel 600	0.125"
	MJ26 - 00000-000-0-00	J	single	Inconel 600	0.250"
	MJ36 - 00000-000-0-00	J	single	316 SS	0.250"
	MK12 - 00000-000-0-00	K	single	304 SS	0.040"
	MK13 - 00000-000-0-00	K	single	304 SS	0.063"
	MK16 - 00000-000-0-00	K	single	304 SS	0.250"
	MK16 - 90000-000-0-00	K	dual	304 SS	0.250"
	MK22 - 00000-000-0-00	K	single	Inconel 600	0.040"
	MK23 - 00000-000-0-00	K	single	Inconel 600	0.063"
	MK24 - 00000-000-0-00	K	single	Inconel 600	0.125"

MqO Wire

Ordering Information (continued)

Model Number	Type	Elements	Sheath	Diameter
MJ14 - 90000-000-0-00	J	dual	304 SS	0.125"
MK24 - 90000-000-0-00	K	dual	Inconel 600	0.125"
MK25 - 90000-000-0-00	K	dual	Inconel 600	0.188"
MK26 - 90000-000-0-00	K	dual	Inconel 600	0.250"
MK25 - 00000-000-0-00	K	single	Inconel 600	0.188"
MK26 - 00000-000-0-00	K	single	Inconel 600	0.250"
MK26 - 90000-000-0-00	K	dual	Inconel 600	0.250"
MK64 - 00000-000-0-00	K	single	Hoskins 2300	0.125"
MK66 - 00000-000-0-00	K	single	Hoskins 2300	0.250"
ME16 - 00000-000-0-00	E	single	304 SS	0.250"
ME16 - 90000-000-0-00	E	dual	304 SS	0.250"
MT16 - 00000-000-0-00	T	single	304 SS	0.250"
MT16 - 90000-000-0-00	T	dual	304 SS	0.250"

Standard Limits

M112 - 00000-000-0-00	J	single	304 SS	0.040"
M113 - 00000-000-0-00	J	single	304 SS	0.063"
M113 - 90000-000-0-00	J	dual	304 SS	0.063"
M114 - 00000-000-0-00	J	single	304 SS	0.125"
M114 - 90000-000-0-00	J	dual	304 SS	0.125"
M115 - 00000-000-0-00	J	single	304 SS	0.188"
M115 - 90000-000-0-00	J	dual	304 SS	0.188"
M116 - 00000-000-0-00	J	single	304 SS	0.250"
M116 - 90000-000-0-00	J	dual	304 SS	0.250"
M117 - 00000-000-0-00	J	single	304 SS	0.375"
M123 - 00000-000-0-00	J	single	Inconel 600	0.063"
M124 - 00000-000-0-00	J	single	Inconel 600	0.125"
M125 - 00000-000-0-00	J	single	Inconel 600	0.188"
M126 - 00000-000-0-00	J	single	Inconel 600	0.250"
M126 - 90000-000-0-00	J	dual	Inconel 600	0.250"
M133 - 00000-000-0-00	J	single	316 SS	0.063"
M133 - 90000-000-0-00	J	dual	316 SS	0.063"
M134 - 00000-000-0-00	J	single	316 SS	0.125"
M134 - 90000-000-0-00	J	dual	316 SS	0.125"
M135 - 00000-000-0-00	J	single	316 SS	0.188"
M135 - 90000-000-0-00	J	dual	316 SS	0.188"
M136 - 00000-000-0-00	J	single	316 SS	0.250"
M136 - 90000-000-0-00	J	dual	316 SS	0.250"
M143 - 00000-000-0-00	J	single	310 SS	0.063"
M144 - 00000-000-0-00	J	single	310 SS	0.125"
M213 - 00000-000-0-00	K	single	304 SS	0.063"
M214 - 00000-000-0-00	K	single	304 SS	0.125"
M215 - 00000-000-0-00	K	single	304 SS	0.188"
M216 - 00000-000-0-00	K	single	304 SS	0.250"
M216 - 90000-000-0-00	K	dual	304 SS	0.250"
M222 - 00000-000-0-00	K	single	Inconel 600	0.040"
M223 - 00000-000-0-00	K	single	Inconel 600	0.063"
M223 - 90000-000-0-00	K	dual	Inconel 600	0.073"
M224 - 00000-000-0-00	K	single	Inconel 600	0.125"
M224 - 90000-000-0-00	K	dual	Inconel 600	0.125"
M225 - 00000-000-0-00	K	single	Inconel 600	0.188"
M225 - 90000-000-0-00	K	dual	Inconel 600	0.188"
M226 - 00000-000-0-00	K	single	Inconel 600	0.250"
M226 - 90000-000-0-00	K	dual	Inconel 600	0.250"
M227 - 00000-000-0-00	K	single	Inconel 600	0.375"
M233 - 00000-000-0-00	K	single	316 SS	0.063"

MqO Wire

Ordering Information (continued)

<u>Model Number</u>	<u>Type</u>	<u>Elements</u>	<u>Sheath</u>	<u>Diameter</u>
M234 - 00000-000-0-00	K	single	316 SS	0.125"
M235 - 00000-000-0-00	K	single	316 SS	0.188"
M236 - 00000-000-0-00	K	single	316 SS	0.250"
M236 - 90000-000-0-00	K	dual	316 SS	0.250"
M244 - 00000-000-0-00	K	single	310 SS	0.125"
M245 - 00000-000-0-00	K	single	310 SS	0.188"
M246 - 00000-000-0-00	K	single	310 SS	0.188"
M313 - 00000-000-0-00	E	single	304 SS	0.063"
M314 - 00000-000-0-00	E	single	304 SS	0.125"
M314 - 00000-000-0-00	E	dual	304 SS	0.125"
M315 - 00000-000-0-00	E	single	304 SS	0.188"
M316 - 00000-000-0-00	E	single	304 SS	0.250"
M334 - 00000-000-0-00	E	single	316 SS	0.125"
M336 - 00000-000-0-00	E	single	316 SS	0.250"
M336 - 90000-000-0-00	E	dual	316 SS	0.250"
M413 - 00000-000-0-00	T	single	304 SS	0.063"
M414 - 00000-000-0-00	T	single	304 SS	0.125"
M415 - 00000-000-0-00	T	single	304 SS	0.188"
M416 - 00000-000-0-00	T	single	304 SS	0.250"
M436 - 00000-000-0-00	T	single	316 SS	0.250"
M436 - 90000-000-0-00	T	dual	316 SS	0.250"
M726 - 00000-000-0-00	N	single	Inconel 600	0.250"

Extension Wire

Introduction

The factory offers bare and insulated thermocouple wire as well as insulated extension wire. Two conductor and three conductor insulated extension wire is commonly used with thermocouples; and three conductor wire with RTD's. We also offer multi-pair insulated thermocouple extension wire and cable for panel or other wiring needs.

Color Codes

Thermocouple Compensating Cable Color Codes

Thermocouple Material	British BS 1843	American ANSI MC 96.1	German DIN 43710	French NFE 18001
T Copper Constantan	+ White - Blue Blue	+ Blue - Red Blue	+ Red - Brown Brown	+ Yellow - Blue Blue
J/L Iron Constantan	+ Yellow - Blue Black	+ White - Red Black	+ Red - Blue Blue	+ Yellow - Black Black
K Nickel Chromium Nickel Aluminum	+ Brown - Blue Red	+ Yellow - Red Yellow	+ Red - Green Green	+ Yellow - Purple Yellow
R Platinum/Platinum 13% Rhodium	+ White - Blue Green	+ Black - Red Green	+ Red - White White	+ Yellow - Green Green
S Platinum/Platinum 10% Rhodium	+ White - Blue Green	+ Black - Red Green	+ Red - White White	+ Yellow - Green Green
E Chromel Constantan	+ Brown - Blue Brown	+ Violet - Red Violet	Red Black Black	+ Yellow - Purple Purple
B Platinum 30% Rh Platinum 6% Rh	- -	+ Grey - Red Grey	Red Black Black	
N Nicrosil / Nisil	+ Orange - Red Orange	+ Orange - Red Orange	+ Orange - Red Orange	+ Orange - Red Orange

Specifications

Bare Thermocouple Wire

Bare, solid wire is available in 8, 14, 16, 18, 20 and 22 gauge, and calibration Types J, K, T and E.

Insulated Multi-pair Wire

20 gauge, insulated, solid, multi-pair extension wire is available in calibration Types J, K and T. Insulation (Fields 6 through 9, code 1900) is 0.015" PVC 0.015" aluminum backed Mylar taped (50% overlaid) with drain and signal wire, 0.045" PVC overall. Individual pairs are twisted.

Insulated Duplex Wire

Thermocouple extension wire must be compatible with the alloys used in the thermocouple. Extension wire for base metal thermocouples is usually constructed of the same alloys as the element. For noble metal elements, base metal alloys are selected to match the characteristics of the element within the operating range of 0° to 150°C.

Two types of wire available – thermocouple grade and extension grade. Thermocouple grade wire is manufactured with alloys to meet the required tolerance. Extension grade wire for base metal thermocouples is made with similar material but is not rated for accuracy at high temperature.

Insulation is the largest factor determining performance of extension wire. Moisture resistance, abrasion resistance, temperature rating and cost are factors to be considered. The following table identifies the characteristics of thermocouple insulated wire. "Code" is the characters that appears in Fields 6 through 9 of the part number.

RTD Extension Wire

Insulated strand wire is available for RTD's with three 16 gauge copper conductors; and two and three 22 gauge nickel clad copper conductors.

Wire Insulation Characteristics

Specifications (continued)

Insulation Construction and Characteristics					Moisture Resistance			Comments		
					Abrasion Resistance					
Insulation					ANSI Color Coded			Rating °C (°F)		
					Code		Each Conductor			
155	Fiberglass 0.015" (replaces 151)	Hot melt compound	Braided synthetic fiber .030"	Moisture resistant compound	290 (550)	-	Y	G	F	Impregnation retained to 150°C (300°F)
157	Teflon TFE tape and Fiberglass 0.020" (replaces 153)	Silicone modified resin	Braided synthetic fiber	Moisture resistance compound	290 (550)	-	Y	G	G	Impregnation retained to 204°C (400°F); Teflon good to 260°C (500°F)
251	Felted synthetic fiber 0.010"	Silicone modified resin	Glass braid 0.006"	Silicone modified resin	288 (550)	343 (650)	Y	G	F	Impregnation retained to 204°C (400°F)
301	Vitreous Silica fiber 0.015"	None	Vitreous Silica fiber 0.020"	None	871 (1600)	1093 (2000)	N	F	F	
302	Double glass braid 0.006"	Silicone modified resin	Glass braid 0.006"	Silicone modified resin	482 (900)	538 (1000)	Y	G	G	Impregnation retained to 204°C (400°F)
303	Enamel/glass braid 0.006"	Silicone modified resin	Glass braid 0.006"	Silicone modified resin	482 (900)	-	Y	F	G	
304	Glass braid 0.006"	Silicone modified resin	Glass braid 0.006"	Silicone modified resin	482 (900)	538 (1000)	Y	F	G	Impregnation retained to 204°C (400°F)
305	Double glass wrap 0.005"	High temp. varnish	Glass braid 0.006"	Silicone modified resin	482 (900)	538 (1000)	Y	F	G	Impregnation retained to 204°C (400°F)
307	Teflon TFE tape (not fused) 0.004" TFE coated glass 0.006"		Teflon coated glass braid 0.006"		482 (900)	538 (1000)	Y	G	E	
309	High temp glass braid 0.012"	-	High temp glass braid 0.012"	Silicone modified resin	704 (1300)	871 (1600)	Y (2)	G	F	Impregnation retained to 204°C (400°F)
311	High temp glass braid 0.012"	-	High temp glass braid 0.012"	Lacquer coated	704 (1300)	871 (1600)	N	F	F	Impregnation retained to 149°F (300°F)
313	Glass braid 0.008/0.006"	Silicone modified resin	Glass braid .008/.006"	Silicone modified resin	482 (900)	538 (1000)	Y	G	G	Impregnation retained to 204°C (400°F)
314	High temp glass braid 0.008"	Silicone modified resin	None - twisted	-	704 (1300)	871 (1600)	Y	G	G	Impregnation retained to 204°C (400°F)
315	Glass braid 0.008"	Silicone Modified resin	None - twisted	-	482 (900)	538 (1000)	Y	G	G	Impregnation retained to 204°C (400°F)
316	Glass braid 0.008/0.006"	Silicone modified resin	High temp glass braid .013/.012"	Silicone modified resin	482 (900)	538 (1000)	Y	G	G	Impregnation retained to 149°C (300°F)
350	Ceramic fiber 0.018"	-	Ceramic fiber 0.018"	-	1430 (2600)	1430 (2600)	N	G	F	
355	Ceramic fiber 0.014"	-	Ceramic fiber 0.014"	-	1430 (2600)	1430 (2600)	N	G	F	

Y = yes, N = No, T = tracers, F = fair, G = good, VG = very good, E = excellent, (2) = both legs

Wire Insulation Characteristics

Specifications (continued)

Insulation Construction and Characteristics (continued)					Moisture Resistance			Comments		
					Abrasion Resistance					
Code	Insulation				ANSI Color Coded					
					Rating °C (°F)		Cont.			
	Each Conductor	Impreg-nation	Overall	Impreg-nation						
401	PVC 0.013" to #20, 0.014" to #16, 0.016" to #14	-	Cotton braid	Wax	88 (190)	-	Y	G	E	
502	PVC 0.013" to #20, 0.014" to #16, 0.016" to #14	-	PVC 0.016"	-	-29 to +105 (-20 to +221)	-	Y	G	E	
503	PVC 0.015"	-	Twisted with filler cotton serve/PVC 0.030"	-	-29 to +105 (-20 to +221)	-	Y	G	E	Strand conductor only
504	Nylon 0.010"	-	Nylon 0.008" to 0.010"	-	177 (356)	-	Y	E	F	
505	PVC 0.012" to 0.014"	-	Ripcord	-	-29 to +105 (-20 to +221)	-	Y	G	E	
507	Teflon FEP extr. 0.008"	-	Teflon FEP extr. 0.010"	-	204 (400)	316 (600)	Y	V-G	E	
508	Teflon TFE tape fused 0.005"	-	Teflon TFE tape fused 0.0075"	-	260 (500)	316 (600)	Y	G	E	
509	Teflon FEP extr. 0.009"	-	Teflon FEP extr. 0.010"	-	204 (400)	316 (600)	Y	V-G	E	Aluminum/Mylar shield with #20 drain wire
510	PVC 0.015"	-	pvc 0.020" twisted	-	-29 to +105 (-20 to +221)	-	Y	G	E	Aluminum/Mylar shield for computer app. #16 uses #18 drain wire, #20 uses #20 drain wire
512	Fused Kapton tape 0.004"	-	Fused Kapton tape 0.004"	-	316 (600)	427 (800)	T	E	E	
513	Fused Kapton tape 0.006"	-	Fused Kapton tape 0.004"	-	316 (600)	427 (800)	T	E	E	
514	Tefzel 0.008"	-	Tefzel 0.010"	-	150 (302)	-	Y	E	E	
515	Tefzel 0.008"	-	Tefzel 0.010" twisted	-	150 (302)	-	Y	E	E	Aluminum/Mylar shield with #20 drain wire
591	Kapton/Kapton tape 0.007/0.004"	-	Kapton tape w/ SS overraid	-	316 (600)	427 (800)	Y	E	E	

Y = yes, N = No, T = tracers, F = fair, G = good, VG = very good, E = excellent, (2) = both legs

Trade Names

Teflon and Kapton are trade names of E. I. duPont de Nemours & Co. Chromel and Alumel are trade names of Hoskins Mfg. Co. Platinel is a trade name of Englehard Industries.

T/C and Extension Wire

Ordering Information

Bare, Insulated Duplex, and Insulated Multi-pair Thermocouple Extension Wire

Following is a list of our standard wire products. Additional wire products are available through special order. Consult the factory for all your wiring needs.

Model No. W - - - **0 - 0 0**
Field No. 1 2 3 4 5 6 7 8 9 10 11 12 13 14 15

Field 1. BASE MODEL

W - Wire

Field 2. WIRE TYPE (ANSI DESIGNATION)

Base Metal

J - Iron-Constantan See following Table
K - Chromel-Alumel See following Table
T - Copper-Constantan See following Table
E - Chromel-Constantan See following Table

Noble Metal

B - Platinum, 30% Rhodium-Platinum, 6% Rhodium See following Table
C - Tungsten, 5% Rhenium-Tungsten, 26% Rhenium See following Table
F - Platinel II See following Table
R - Platinum, 13% Rhodium-Platinum See following Table
S - Platinum, 10% Rhodium-Platinum See following Table

Fields 3, 4. AMERICAN WIRE GAUGE

XX - AWG Number See following Table

Field 5. WIRE GRADE, CONSTRUCTION, AND LIMITS OF ERROR

1 - T/C grade, solid, standard limits See following Table
2 - T/C grade, solid, special limits See following Table
3 - T/C grade, stranded, standard limits See following Table
4 - T/C grade, stranded, special limits See following Table
5 - Extension grade, solid, standard limits See following Table
6 - Extension grade, solid, special limits See following Table
7 - Extension grade, stranded, standard limits See following Table
8 - Extension grade, stranded, special limits See following Table

Field 6. STAINLESS STEEL OVERBRAID

1 - No
2 - Yes

Fields 7 through 9. INSULATION

Bare Wire

000 - None

T/C and Extension Wire

Ordering Information (continued)

Fields 7 through 9. INSULATION (continued)

Insulated Duplex Wire

155 -	Fiberglass 0.015"	See following Table
157 -	Teflon TFE tape and Fiberglass 0.020"	See following Table
251 -	Felted synthetic fiber 0.010"	See following Table
301 -	Viterous Silica fiber	See following Table
302 -	Double glass braid	See following Table
303 -	Enamel/glass braid	See following Table
304 -	Glass braid	See following Table
305 -	Double glass wrap	See following Table
307 -	Teflon coated glass wrap	See following Table
309 -	High temperature glass braid	See following Table
311 -	High temperature glass braid	See following Table
313 -	Glass braid	See following Table
314 -	High temperature glass braid	See following Table
315 -	Glass braid	See following Table
316 -	Glass braid	See following Table
350 -	Ceramic fiber	See following Table
355 -	Ceramic fiber	See following Table
401 -	PVC	See following Table
502 -	PVC	See following Table
503 -	PVC with Cotton Filler	See following Table
504 -	Nylon	See following Table
505 -	PVC	See following Table
507 -	Teflon FEP	See following Table
508 -	Teflon TFE	See following Table
509 -	Teflon FEP	See following Table
510 -	PVC	See following Table
512 -	Fused Kapton tape	See following Table
513 -	Fused Kapton tape	See following Table
514 -	Tefzel	See following Table
515 -	Tefzel	See following Table
591 -	Kapton/Kapton tape	See following Table

Insulated Multi-pair Cable

100 -	PVC/Aluminized Mylar	See following Table
-------	----------------------------	---------------------

Field 10. CONDUCTOR ALLOY

Insulated Duplex Wire and Insulated Multi-pair Cable

0 -	Not applicable
-----	----------------

Bare Wire

1 -	Positive leg only (first alloy listed in Wire Type, Field 2)	See following Table
2 -	Negative leg only (second alloy listed in Wire Type, Field 2)	See following Table

Fields 11, 12. NUMBER OF CONDUCTORS

Insulated Duplex Wire

00 -	One pair	See following Table
------	----------------	---------------------

Bare Wire

01 -	Single conductor	See following Table
------	------------------------	---------------------

Insulated Multi-pair Cable

04 -	Four pair	See following Table
08 -	Eight pair	See following Table
12 -	Twelve pair	See following Table
16 -	Sixteen pair	See following Table
20 -	Twenty pair	See following Table
24 -	Twenty-four pair	See following Table

Fields 13 through 15. RESERVED

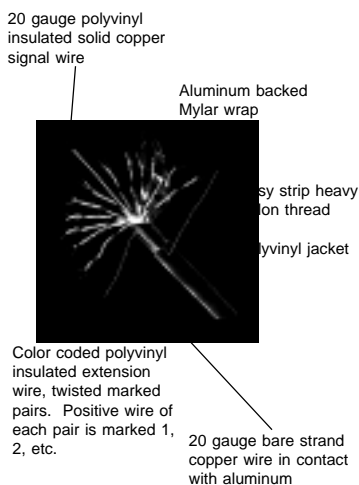

T/C and Extension Wire

Base Metal Wire Table

Bare Noble Metal Wire Sold by the inch

Model Number	Description
WB24-11000-101	Type B, 24 gauge, positive lead
WB24-11000-201	Type B, 24 gauge, negative lead
WC24-11000-101	Type C, 24 gauge, positive lead
WC24-11000-201	Type C, 24 gauge, negative lead
WR24-11000-101	Type R, 24 gauge, positive lead
WR24-11000-201	Type R, 24 gauge, negative lead
WS24-11000-101	Type S, 24 gauge, positive lead
WS24-11000-201	Type S, 24 gauge, negative lead Use WR24-11000-201

Bare Base Metal Wire Sold by the pound

Model Number	Description
WE08-11000-101-0-01	Type eE, 08 gauge, positive lead Use
WE08-11000-201-0-01, 20 ft./lb.	Type E, 08 gauge, negative lead
WE14-11000-101-0-01	Type E, 14 gauge, positive lead Use
WE14-11000-201-0-01, 80 ft./lb.	Type E, 14 gauge, negative lead
WJ08-11000-101-0-01, 23 ft./lb.	Type J, 08 gauge, positive lead
WJ08-11000-201-0-01, 20 ft./lb.	Type J, 08 gauge, negative lead
WJ14-11000-101-0-01, 80 ft./lb.	Type J, 14 gauge, positive lead
WJ14-11000-201-0-01, 91 ft./lb.	Type J, 14 gauge, negative lead
WJ20-11000-101-0-01, 366 ft./lb.	Type J, 20 gauge, positive lead
WJ20-11000-201-0-01, 322 ft./lb.	Type J, 20 gauge, negative lead
WK08-11000-101-0-01, 21 ft./lb.	Type K, 08 gauge, positive lead
WK08-11000-201-0-01, 21 ft./lb.	Type K, 08 gauge, negative lead
WK08-21000-101-0-01, 21 ft./lb.	Type K, 08 gauge, positive lead
WK08-21000-201-0-01, 21 ft./lb.	Type K, 08 gauge, negative lead
WK14-11000-101-0-01, 83 ft./lb.	Type K, 14 gauge, positive lead
WK14-11000-201-0-01, 83 ft./lb.	Type K, 14 gauge, negative lead
WK14-21000-101-0-01, 83 ft./lb.	Type K, 14 gauge, positive lead
WK14-21000-201-0-01, 83 ft./lb.	Type K, 14 gauge, negative lead
WK20-11000-101-0-01, 331 ft./lb.	Type K, 20 gauge, positive lead
WK20-11000-201-0-01, 331 ft./lb.	Type K, 20 gauge, negative lead
WK20-21000-101-0-01, 331 ft./lb.	Type K, 20 gauge, positive lead
WK20-21000-201-0-01, 331 ft./lb.	Type K, 20 gauge, negative lead
WT14-11000-101-0-01, 81 ft./lb.	Type T, 14 gauge, positive lead (Obsolete)
WT14-11000-201-0-01, 80 ft./lb.	Type T, 14 gauge, negative lead (Obsolete)
WT20-11000-101-0-01, 324 ft./lb.	Type T, 20 gauge, positive lead
WT20-11000-201-0-01, 322 ft./lb.	Type T, 20 gauge, negative lead
WT20-21000-101-0-01, 324 ft./lb.	Type T, 20 gauge, positive lead
WT20-21000-201-0-01, 322 ft./lb.	Type T, 20 gauge, negative lead

T/C and Extension Wire

Insulated Wire

Inventoried wire can be purchased in any length. There is a \$10.00 spooling charge for lengths less than 1000 feet. The minimum order for wire that is not inventoried is 2000 feet. We reserve the right to ship and invoice plus or minus 10% of the requested length.

Type B insulated wire, extension grade

Model Number	Description
WB20-51304	Type B, 20 gauge, solid, extension grade
WB20-51502	Type B, 20 gauge, solid, extension grade

Type C insulated wire, extension grade

Model Number	Description
WC24-51304	Type C, 24 gauge, solid, extension grade

Type E insulated wire, thermocouple grade

Model Number	Description
WE20-11304	Type E, 20 gauge, solid, thermocouple grade
WE20-12304	Type E, 20 gauge, solid, thermocouple grade

Type E insulated wire, extension grade

Model Number	Description
WE20-51502	Type E, 20 gauge, solid, extension grade

Type J insulated wire, thermocouple grade

Model Number	Description
WJ18-31304	Type J, 18 gauge, stranded, thermocouple grade
WJ20-11304	Type J, 20 gauge, solid, thermocouple grade
WJ20-11305	Type J, 20 gauge, solid, thermocouple grade
WJ20-11307	Type J, 20 gauge, solid, thermocouple grade
WJ20-11321	Type J, 20 gauge, solid, thermocouple grade
WJ20-11504	Type J, 20 gauge, solid, thermocouple grade
WJ20-11505	Type J, 20 gauge, solid, thermocouple grade
WJ20-11507	Type J, 20 gauge, solid, thermocouple grade
WJ20-11508	Type J, 20 gauge, solid, thermocouple grade
WJ20-11509	Type J, 20 gauge, solid, thermocouple grade
WJ20-12305	Type J, 20 gauge, solid, thermocouple grade
WJ20-21305	Type J, 20 gauge, solid, thermocouple grade
WJ20-31302	Type J, 20 gauge, stranded, thermocouple grade
WJ20-32302	Type J, 20 gauge, stranded, thermocouple grade
WJ20-32507	Type J, 20 gauge, stranded, thermocouple grade
WJ20-41302	Type J, 20 gauge, stranded, thermocouple grade
WJ20-42302	Type J, 20 gauge, stranded, thermocouple grade
WJ24-11304	Type J, 24 gauge, solid, thermocouple grade
WJ24-11305	Type J, 24 gauge, solid, thermocouple grade
WJ24-11505	Type J, 24 gauge, solid, thermocouple grade
WJ24-12305	Type J, 24 gauge, solid, thermocouple grade
WJ24-31305	Type J, 24 gauge, stranded, thermocouple grade
WJ24-32305	Type J, 24 gauge, stranded, thermocouple grade
WJ30-11304	Type J, 30 gauge, solid, thermocouple grade

T/C and Extension Wire

Insulated Wire (continued)

Type J insulated wire, extension grade

Model Number	Description
WJ14-51502	Type J, 14 gauge, solid, extension grade
WJ16-51155	Type J, 16 gauge, solid, extension grade
WJ16-51157	Type J, 16 gauge, solid, extension grade
WJ16-51303	Type J, 16 gauge, solid, extension grade (Obsolete)
WJ16-51502	Type J, 16 gauge, solid, extension grade
WJ16-51510	Type J, 16 gauge, solid, extension grade
WJ16-71155	Type J, 16 gauge, stranded, extension grade
WJ16-71515	Type J, 16 gauge, stranded, extension grade
WJ20-51502	Type J, 20 gauge, solid, extension grade
WJ20-51510	Type J, 20 gauge, solid, extension grade
WJ20-71502	Type J, 20 gauge, stranded, extension grade
WJ20-71510	Type J, 20 gauge, stranded, extension grade
WJ20-51100-002	Type J, 20 gauge, solid, extension grade
WJ20-51100-004	Type J, 20 gauge, solid, extension grade
WJ20-51100-008	Type J, 20 gauge, solid, extension grade
WJ20-51100-012	Type J, 20 gauge, solid, extension grade
WJ20-51100-016	Type J, 20 gauge, solid, extension grade
WJ20-51100-020	Type J, 20 gauge, solid, extension grade
WJ20-51100-024	Type J, 20 gauge, solid, extension grade

Type K insulated wire, thermocouple grade

Model Number	Description
WK14-11309	Type K, 14 gauge, solid, thermocouple grade
WK20-11301	Type K, 20 gauge, solid, thermocouple grade
WK20-11304	Type K, 20 gauge, solid, thermocouple grade
WK20-11305	Type K, 20 gauge, solid, thermocouple grade
WK20-11311	Type K, 20 gauge, solid, thermocouple grade
WK20-11313	Type K, 20 gauge, solid, thermocouple grade
WK20-11314	Type K, 20 gauge, solid, thermocouple grade
WK20-11315	Type K, 20 gauge, solid, thermocouple grade
WK20-11321	Type K, 20 gauge, solid, thermocouple grade
WK20-11507	Type K, 20 gauge, solid, thermocouple grade
WK20-11509	Type K, 20 gauge, solid, thermocouple grade
WK20-11511	Type K, 20 gauge, solid, thermocouple grade
WK20-11513	Type K, 20 gauge, solid, thermocouple grade
WK20-12305	Type K, 20 gauge, solid, thermocouple grade
WK20-21301	Type K, 20 gauge, solid, thermocouple grade
WK20-21311	Type K, 20 gauge, solid, thermocouple grade
WK20-21350	Type K, 20 gauge, solid, thermocouple grade
WK20-31302	Type K, 20 gauge, stranded, thermocouple grade
WK20-31507	Type K, 20 gauge, stranded, thermocouple grade
WK20-32302	Type K, 20 gauge, stranded, thermocouple grade
WK24-11304	Type K, 24 gauge, solid, thermocouple grade
WK24-11305	Type K, 24 gauge, solid, thermocouple grade

T/C and Extension Wire

Insulated Wire (continued)

Type K insulated wire, extension grade

Model Number	Description
WK14-51155	Type K, 14 gauge, solid, extension grade
WK14-71155	Type K, 14 gauge, stranded, extension grade
WK16-51155	Type K, 16 gauge, solid, extension grade
WK16-51157	Type K, 16 gauge, solid, extension grade
WK16-51502	Type K, 16 gauge, solid, extension grade
WK16-71155	Type K, 16 gauge, stranded, extension grade
WK20-51502	Type K, 20 gauge, solid, extension grade
WK20-51510	Type K, 20 gauge, solid, extension grade
WK20-71502	Type K, 20 gauge, stranded, extension grade
WK20-71510	Type K, 20 gauge, stranded, extension grade
WK20-51100-002	Type K, 20 gauge, solid, extension grade
WK20-51100-004	Type K, 20 gauge, solid, extension grade
WK20-51100-008	Type K, 20 gauge, solid, extension grade
WK20-51100-012	Type K, 20 gauge, solid, extension grade
WK20-51100-016	Type K, 20 gauge, solid, extension grade
WK20-51100-020	Type K, 20 gauge, solid, extension grade
WK20-51100-024	Type K, 20 gauge, solid, extension grade
WN20-31302	Type N, 20 gauge, stranded, thermocouple grade

Type R insulated wire, extension grade

Model Number	Description
WR16-51155	Type R, 16 gauge, solid, extension grade
WR16-51157	Type R, 16 gauge, solid, extension grade
WR16-71155	Type R, 16 gauge, stranded, extension grade
WR20-51304	Type R, 20 gauge, solid, extension grade
WR20-51502	Type R, 20 gauge, solid, extension grade
WR20-51507	Type R, 20 gauge, solid, extension grade
WR20-51509	Type R, 20 gauge, solid, extension grade
WR20-51510	Type R, 20 gauge, solid, extension grade

Type T insulated wire, thermocouple grade

Model Number	Description
WT20-11304	Type T, 20 gauge, solid, thermocouple grade
WT20-11305	Type T, 20 gauge, solid, thermocouple grade
WT20-11507	Type T, 20 gauge, solid, thermocouple grade
WT20-11508	Type T, 20 gauge, solid, thermocouple grade
WT20-21508	Type T, 20 gauge, solid, thermocouple grade
WT20-31512	Type T, 20 gauge, stranded, thermocouple grade
WT24-11304	Type T, 24 gauge, solid, thermocouple grade
WT30-11305	Type T, 30 gauge, solid, thermocouple grade
WT16-51502	Type T, 16 gauge, solid, extension grade

Type T insulated wire, extension grade

Model Number	Description
WT16-71515	Type T, 16 gauge, stranded, extension grade
WT20-51502	Type T, 20 gauge, solid, extension grade
WT20-51510	Type T, 20 gauge, solid, extension grade
WT20-71502	Type T, 20 gauge, stranded, extension grade
WT20-51100-004	Type T, 20 gauge, solid, extension grade
WT20-51100-008	Type T, 20 gauge, solid, extension grade
WT20-51100-012	Type T, 20 gauge, solid, extension grade
WT20-51100-024	Type T, 20 gauge, solid, extension grade

T/C Elements

Base Metal Thermocouple Elements

Introduction

Elements are available in both base metal and noble metal. Noble metal elements are listed near the end of this section.

Base metal thermocouples are used directly as temperature sensing elements, or as replacement or component items for insertion into a protection tube. Part numbers for elements for most common sensor configurations can be easily composed as illustrated later in this section. However, sensors with code 24, 30, 41 or 42 protection tubes (Fields 5, 6 of the sensor part number) may require special element assemblies as indicated in the table below. Complete part numbers for these special assemblies are listed immediately after the common configuration listing. (See Quick Reference Index below.)

Gauge	Tube*	Straight		90°		
		Single	Dual	Single	Dual	
8	24 or 30	A-11727				
	41	A-11888	A-11712	A-11809		
	42	A-11711		A-10462		
14 or 20	41	A-11888		A-11809	A-10504	
	42	A-11711	A-11712	A-10462		

*These are codes that appear in Fields 5, 6 of the sensor model number. They are defined as follows:
 24 - 11/16" o.d. high temperature Mullite
 30 - 11/16" o.d. aluminum oxide
 41 - 1-1/4" o.d. ceramic coated steel
 42 - 1-1/4" o.d. ceramic coated steel with spring

Quick Reference Index

Base metal, common configuration	Page 6-18
Base metal, special configuration	Page 6-25
Noble metal	Page 6-28

Element Construction

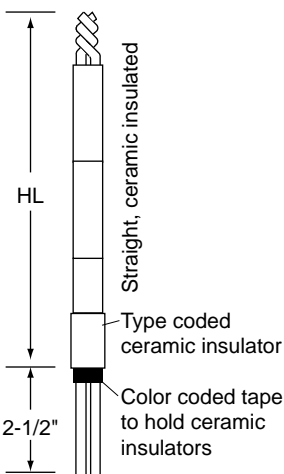

Element construction codes I and H (Field 4) define ceramic insulated elements on which the following insulators are used:

Gauge	Single Element Insulator	Dual Element Insulator
8	51-008	51-008 (two separate elements)
14	51-022	51-051
20	51-027	51-052

Compatibility between these constructions and a given protection tube depends on the inside diameter of the tube. Inside diameter must be at least as large as the maximum outside diameter listed in the following compatibility table (C = compatible):

Gauge Code (Fields 2, 3)	Thermocouple Type (Field 1)					Max o.d. w/insulators	
	J	K	I	E	N	Single	Dual
08, 09	C	C	n/a	C	C	31/64"	9/16"
14, 15	C	C	C	C	C	5/16"	5/16"
20, 21	C	C	C	C	C	10/32"	3/16"

T/C Elements

Element Construction (continued)

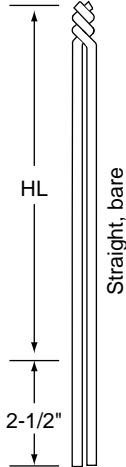

Element construction code O (Field 4) defines non-insulated (bare) elements for which the user must provide suitable insulation.

Compatible base metal element codes (Field 4) are shown in the table below for each protection tube/wire gauge combination.

I = 1, 2, 3, 4

H = H, 5, 6

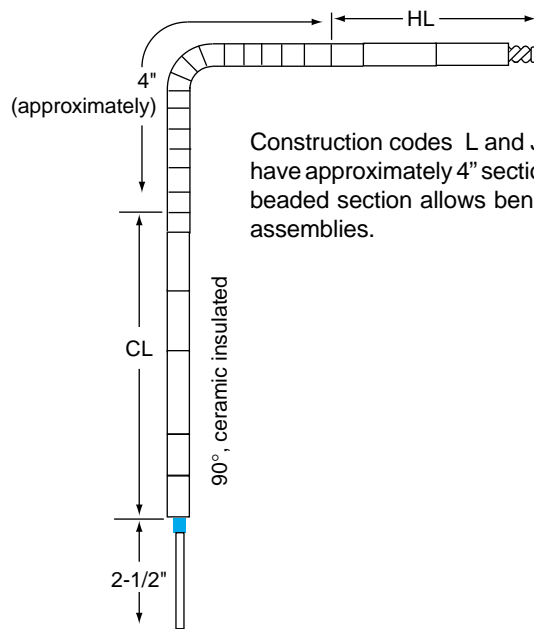

Construction codes L and J (Field 4) define ceramic insulated elements which have approximately 4" section of bead insulation between hot and cold legs. This beaded section allows bending the element for placement into the 90° elbow assemblies.

Element Compatibility

Note: "I" is the letter "I," not the numeral "1."

Field 4. Element, Junction Style Definition	Field 4 Code		
	Straight	90° Elbow	90° Bend
Single, twisted, grounded	I	L	A
Single, twisted, ungrounded	2	C	R
Single, butt welded, grounded	3	E	S
Single, butt welded, ungrounded	4	F	T
Dual, twisted, grounded	H	J	K
Dual, common butt welded, ungrounded	5	G	U
Dual, isolated butt welded, ungrounded	6	M	V

T/C Elements

Element Compatibility (continued)

Compatible element codes (Field 4) are shown in the table below for each protection tube/wire gauge combination.

Note: "I" is the letter "I," not the numeral "1."

Fields 5, 6. Protection Tube		Fields 2, 3. Wire Gauge Codes		
Code / Description		08 or 09	14 or 15	20 or 21
01	Cast iron coated	I, 2, 3, 4, H, 5, 6, L, C, E, F, J, G, M	I, 2, 3, 4, H, 5, 6, L, C, E, F, J, G, M	I, 2, 3, 4, H, 5, 6, L, C, E, F, J, G, M
02	Black steel, 1/4" NPS	n/a		
03	Black steel, 1/2" NPS	I, 2, 3, 4, L, C, E, F, A, R, S, T		
04	Black steel, 3/4" NPS	All except K, U, V	All	
05	Black steel, 1" NPS			
06	Welded steel, 1/8" NPS	n/a	n/a	I, 2, 3, 4, H, 5, 6
07	Welded steel, 1/4" NPS	n/a	I, 2, 3, 4, H, 5, 6	
08	Welded steel, 1" NPS	All except K, U, V	All	
09	Cast iron	I, 2, 3, 4, H, 5, 6, L, C, E, F, J, G, M	I, 2, 3, 4, H, 5, 6, L, C, E, F, J, G, M	
11	446 SS, 3/4" NPS	All except K, U, V	All except A, R, S, T	All except A, R, S, T
12	446 SS, 1/2" NPS	I, 2, 3, 4, L, C, E, F, A, R, S, T		
13	446 SS, 1" NPS	All except K, U, V		
14	Pure nickel, 1/2" NPS	I, 2, 3, 4, L, C, E, F		
16	Inconel 601, 1/2" NPS	I, 2, 3, 4, L, C, E, F, A, R, S, T		
17	Inconel 601, 3/4" NPS	All except K, U, V		
18	304 SS, 1/4" NPS	n/a		
19	304 SS, 1/2" NPS	I, 2, 3, 4, L, C, E, F, A, R, S, T	All	
21	Silicon carbide, 1-3/4" o.d.	I, 2, 3, 4, H, 5, 6, L, C, E, F	I, 2, 3, 4, H, 5, 6	
22	Silicon carbide w/collar	I, 2, 3, 4, H, 5, 6	n/a	I, 2, 3, 4, H, 5, 6, L, C, E, F, J, G, M
23	H.T. Mullite, 3/8" o.d.	n/a	I, 4	I, 4, H, 5, 6
24	H.T. Mullite, 11/16" o.d.	A-11727	I, 4, H, 5, 6, L, F, J, G, M	
25	H.T. Mullite, 1" o.d.	I, 4, H, 5, 6, L, F, J, G, M	I, 4, H, 5, 6, L, F, J, G, M	
26	Incoloy 800, 1/2" NPS	I, 2, 3, 4, L, C, E, F, A, R, S, T	I, 2, 3, 4, H, 5, 6, L, C, E, F, J, G, M	
27	Incoloy 800, 3/4" NPS	I, 2, 3, 4, H, 5, 6, L, C, E, F, J, G, M	I, 2, 3, 4, H, 5, 6, L, C, E, F, J, G, M	
28	Metal ceramic, 7/8" o.d.	I, L, F	I, 2, 3, 4, H, 5, 6, L, C, E, F, J, G, M	
29	Aluminum oxide, 3/8" o.d.	n/a	I, 4	I, 4, H, 5, 6
30	Aluminum oxide, 11/16" o.d.	A-11727	I, 4, H, 5, 6, L, F, J, G, M	
31	Aluminum oxide, 1" o.d.	I, 4, H, 5, 6, L, F, J, G, M	I, 4, H, 5, 6, L, F, J, G, M	
41	Ceramic clad	A-10462, A-10504, A-11711 A-11712, A-11809, A-11888	I, 2, 3, 4, H, 5, 6, L, C, E, F, J, G, M	
42	Ceramic clad w/spring			
44	316 SS, 1/2" NPS	I, 2, 3, 4, L, C, E, F, A, R, S, T	All	
46	Silicon carbide pipe, reinforced	I, 2, 3, 4, L, C, E, F	I, 2, 3, 4, H, 5, 6, L, C, E, F, J, G, M	
47	316 SS, 3/4" NPS	All except K, U, V	All	
65	304 SS, 0.160" x 0.185"	n/a	n/a	I
66	304 SS, 0.194" x 0.250"			
67	304 SS, 0.305" x 0.375"	n/a	I, 4	I, 2, 3, 4, H, 5, 6
68	316 SS, 0.160" x 0.185"	n/a	n/a	I, 4
69	316 SS, 0.194" x 0.250"			
70	316 SS, 0.305" x 0.375"	n/a	I	I, 2, 3, 4, H, 5, 6
72	Inconel 601, 0.194" x 0.250	n/a	n/a	I
73	Inconel 601, 0.305" x 0.375"	n/a	I	I, 2, 3, 4, H, 5, 6

T/C Elements

Ordering Information

Complete this part number, then refer to the tables on following pages. Straight element part numbers are listed first, followed by 90° element part numbers.

Model No. - 0 0 0 - 0 - 0 - 0 0
Field No. 1 2 3 4 5 6 7 8 9 10 11 12 13 14 15

Field 1. THERMOCOUPLE TYPE

- J - Iron-Constantan
- K - Chromel-Alumel
- T - Copper-Constantan
- E - Chromel-Constantan

Fields 2, 3. WIRE GAUGE; LIMITS OF ERROR

- 08 - 8 gauge; standard (not compatible with Field 1, code T)
- 09 - 8 gauge; special (not compatible with Field 1, code T)
- 14 - 14 gauge; standard
- 15 - 14 gauge; special
- 20 - 20 gauge; standard
- 21 - 20 gauge; special

Field 4. ELEMENT CONSTRUCTION

- I - Straight single element two hole ceramic insulators
- L - 90° single element two hole ceramic insulators
- O - Bare wire element no insulators
- H -* Straight dual element two hole ceramic insul (2 separate elements)
- J - 90° dual element two hole ceramic insulators
- 2 - Twisted single ungrounded
- B - Twisted single beaded
- 3 - Butt welded single grounded
- 4 - Butt welded single ungrounded
- 5 - Butt welded dual common ungrounded
- 6 - Butt welded dual isolated ungrounded

*Dual 14 and 20 gauge elements are supplied with four hole insulators on straight element styles; 8 gauge uses two separate elements

Fields 5, 6, 7. RESERVED

Fields 8, 9. HOT LEG (DIMENSION "HL")

- HL - Length "HL" in whole inches

Field 10. RESERVED

Fields 11, 12. COLD LEG (DIMENSION "CL")

- 00 - None. Straight element
- CL - Length "CL" in whole inches

Fields 13, 14, 15. RESERVED

Note: "l" is the letter "l,"
not the numeral "1."

T/C Elements

T/C Element Table

Straight Elements ("1" is the letter "I," not the numeral "1.")

E142-000XX-000-0-00	Type E, 14 Gauge, Single, Standard Limits, Twisted Ungrounded Junction
E143-000XX-000-0-00	Type E, 14 Gauge, Single, Standard Limits, Butt Welded Grounded Junction
E144-000XX-000-0-00	Type E, 14 Gauge, Single, Standard Limits, Butt Welded Ungrounded Junction
E145-000XX-000-0-00	Type E, 14 Gauge, Dual, Standard Limits, Common Ungrounded Junction
E146-000XX-000-0-00	Type E, 14 Gauge, Dual, Standard Limits, Isolated Ungrounded Junction
E14H-000XX-000-0-00	Type E, 14 Gauge, Dual, Standard Limits, Twisted Grounded Junction
E14I-000XX-000-0-00	Type E, 14 Gauge, Single, Standard Limits, Twisted Grounded Junction
E14O-000XX-000-0-00	Type E, 14 Gauge, Single, Standard Limits, Twisted Grounded Junction, No Insulators
E152-000XX-000-0-00	Type E, 14 Gauge, Single, Special Limits, Twisted Ungrounded Junction
E153-000XX-000-0-00	Type E, 14 Gauge, Single, Special Limits, Butt Welded Grounded Junction
E154-000XX-000-0-00	Type E, 14 Gauge, Single, Special Limits, Butt Welded Ungrounded Junction
E155-000XX-000-0-00	Type E, 14 Gauge, Dual, Special Limits, Common Ungrounded Junction
E156-000XX-000-0-00	Type E, 14 Gauge, Dual, Special Limits, Isolated Ungrounded Junction
E15H-000XX-000-0-00	Type E, 14 Gauge, Dual, Special Limits, Twisted Grounded Junction
E15I-000XX-000-0-00	Type E, 14 Gauge, Single, Special Limits, Twisted Grounded Junction
E15O-000XX-000-0-00	Type E, 14 Gauge, Single, Special Limits, Twisted Grounded Junction, No Insulators
E202-000XX-000-0-00	Type E, 20 Gauge, Single, Standard Limits, Twisted Ungrounded Junction
E203-000XX-000-0-00	Type E, 20 Gauge, Single, Standard Limits, Butt Welded Grounded Junction
E204-000XX-000-0-00	Type E, 20 Gauge, Single, Standard Limits, Butt Welded Ungrounded Junction
E205-000XX-000-0-00	Type E, 20 Gauge, Dual, Standard Limits, Common Ungrounded Junction
E206-000XX-000-0-00	Type E, 20 Gauge, Dual, Standard Limits, Isolated Ungrounded Junction
E20H-000XX-000-0-00	Type E, 20 Gauge, Dual, Standard Limits, Twisted Grounded Junction
E20I-000XX-000-0-00	Type E, 20 Gauge, Single, Standard Limits, Twisted Grounded Junction
E20O-000XX-000-0-00	Type E, 20 Gauge, Single, Standard Limits, Twisted Grounded Junction, No Insulators
E212-000XX-000-0-00	Type E, 20 Gauge, Single, Special Limits, Twisted Ungrounded Junction
E213-000XX-000-0-00	Type E, 20 Gauge, Single, Special Limits, Butt Welded Grounded Junction
E214-000XX-000-0-00	Type E, 20 Gauge, Single, Special Limits, Butt Welded Ungrounded Junction
E215-000XX-000-0-00	Type E, 20 Gauge, Dual, Special Limits, Common Ungrounded Junction
E216-000XX-000-0-00	Type E, 20 Gauge, Dual, Special Limits, Isolated Ungrounded Junction
E21H-000XX-000-0-00	Type E, 20 Gauge, Dual, Special Limits, Twisted Grounded Junction
E21I-000XX-000-0-00	Type E, 20 Gauge, Single, Special Limits, Twisted Grounded Junction
E21O-000XX-000-0-00	Type E, 20 Gauge, Single, Special Limits, Twisted Grounded Junction, No Insulators
J082-000XX-000-0-00	Type J, 8 Gauge, Single, Standard Limits, Twisted Ungrounded Junction
J083-000XX-000-0-00	Type J, 8 Gauge, Single, Standard Limits, Butt Welded Grounded Junction
J084-000XX-000-0-00	Type J, 8 Gauge, Single, Standard Limits, Butt Welded Ungrounded Junction
J085-000XX-000-0-00	Type J, 8 Gauge, Dual, Standard Limits, Common Ungrounded Junction
J086-000XX-000-0-00	Type J, 8 Gauge, Dual, Standard Limits, Isolated Ungrounded Junction
J08H-000XX-000-0-00	Type J, 8 Gauge, Dual, Standard Limits, Twisted Grounded Junction
J08I-000XX-000-0-00	Type J, 8 Gauge, Single, Standard Limits, Twisted Grounded Junction
J08O-000XX-000-0-00	Type J, 8 Gauge, Single, Standard Limits, Twisted Grounded Junction, No Insulators
J092-000XX-000-0-00	Type J, 8 Gauge, Single, Special Limits, Twisted Ungrounded Junction
J093-000XX-000-0-00	Type J, 8 Gauge, Single, Special Limits, Butt Welded Grounded Junction
J094-000XX-000-0-00	Type J, 8 Gauge, Single, Special Limits, Butt Welded Ungrounded Junction
J095-000XX-000-0-00	Type J, 8 Gauge, Dual, Special Limits, Common Ungrounded Junction
J096-000XX-000-0-00	Type J, 8 Gauge, Dual, Special Limits, Isolated Ungrounded Junction
J09H-000XX-000-0-00	Type J, 8 Gauge, Dual, Special Limits, Twisted Grounded Junction
J09I-000XX-000-0-00	Type J, 8 Gauge, Single, Special Limits, Twisted Grounded Junction
J09O-000XX-000-0-00	Type J, 8 Gauge, Single, Special Limits, Twisted Grounded Junction, No Insulators
J142-000XX-000-0-00	Type J, 14 Gauge, Single, Standard Limits, Twisted Ungrounded Junction
J143-000XX-000-0-00	Type J, 14 Gauge, Single, Standard Limits, Butt Welded Grounded Junction
J144-000XX-000-0-00	Type J, 14 Gauge, Single, Standard Limits, Butt Welded Ungrounded Junction
J145-000XX-000-0-00	Type J, 14 Gauge, Dual, Standard Limits, Common Ungrounded Junction
J146-000XX-000-0-00	Type J, 14 Gauge, Dual, Standard Limits, Isolated Ungrounded Junction
J14H-000XX-000-0-00	Type J, 14 Gauge, Dual, Standard Limits, Twisted Grounded Junction

T/C Elements

T/C Element Table (continued)

Straight Elements ("I" is the letter "I," not the numeral "1.")

J14I-000XX-000-0-00	Type J, 14 Gauge, Single, Standard Limits, Twisted Grounded Junction
J14O-000XX-000-0-00	Type J, 14 Gauge, Single, Standard Limits, Twisted Grounded Junction, No Insulators
J152-000XX-000-0-00	Type J, 14 Gauge, Single, Special Limits, Twisted Ungrounded Junction
J153-000XX-000-0-00	Type J, 14 Gauge, Single, Special Limits, Butt Welded Grounded Junction
J154-000XX-000-0-00	Type J, 14 Gauge, Single, Special Limits, Butt Welded Ungrounded Junction
J155-000XX-000-0-00	Type J, 14 Gauge, Dual, Special Limits, Common Ungrounded Junction
J156-000XX-000-0-00	Type J, 14 Gauge, Dual, Special Limits, Isolated Ungrounded Junction
J15H-000XX-000-0-00	Type J, 14 Gauge, Dual, Special Limits, Twisted Grounded Junction
J15I-000XX-000-0-00	Type J, 14 Gauge, Single, Special Limits, Twisted Grounded Junction
J15O-000XX-000-0-00	Type J, 14 Gauge, Single, Special Limits, Twisted Grounded Junction, No Insulators
J202-000XX-000-0-00	Type J, 20 Gauge, Single, Standard Limits, Twisted Ungrounded Junction
J203-000XX-000-0-00	Type J, 20 Gauge, Single, Standard Limits, Butt Welded Grounded Junction
J204-000XX-000-0-00	Type J, 20 Gauge, Single, Standard Limits, Butt Welded Ungrounded Junction
J205-000XX-000-0-00	Type J, 20 Gauge, Dual, Standard Limits, Common Ungrounded Junction
J206-000XX-000-0-00	Type J, 20 Gauge, Dual, Standard Limits, Isolated Ungrounded Junction
J20H-000XX-000-0-00	Type J, 20 Gauge, Dual, Standard Limits, Twisted Grounded Junction
J20I-000XX-000-0-00	Type J, 20 Gauge, Single, Standard Limits, Twisted Grounded Junction
J20O-000XX-000-0-00	Type J, 20 Gauge, Single, Standard Limits, Twisted Grounded Junction, No Insulators
J212-000XX-000-0-00	Type J, 20 Gauge, Single, Special Limits, Twisted Ungrounded Junction
J213-000XX-000-0-00	Type J, 20 Gauge, Single, Special Limits, Butt Welded Grounded Junction
J214-000XX-000-0-00	Type J, 20 Gauge, Single, Special Limits, Butt Welded Ungrounded Junction
J215-000XX-000-0-00	Type J, 20 Gauge, Dual, Special Limits, Common Ungrounded Junction
J216-000XX-000-0-00	Type J, 20 Gauge, Dual, Special Limits, Isolated Ungrounded Junction
J21H-000XX-000-0-00	Type J, 20 Gauge, Dual, Special Limits, Twisted Grounded Junction
J21I-000XX-000-0-00	Type J, 20 Gauge, Single, Special Limits, Twisted Grounded Junction
J21O-000XX-000-0-00	Type J, 20 Gauge, Single, Special Limits, Twisted Grounded Junction, No Insulators
K082-000XX-000-0-00	Type K, 8 Gauge, Single, Standard Limits, Twisted Ungrounded Junction
K083-000XX-000-0-00	Type K, 8 Gauge, Single, Standard Limits, Butt Welded Grounded Junction
K084-000XX-000-0-00	Type K, 8 Gauge, Single, Standard Limits, Butt Welded Ungrounded Junction
K085-000XX-000-0-00	Type K, 8 Gauge, Dual, Standard Limits, Common Ungrounded Junction
K086-000XX-000-0-00	Type K, 8 Gauge, Dual, Standard Limits, Isolated Ungrounded Junction
K08H-000XX-000-0-00	Type K, 8 Gauge, Dual, Standard Limits, Twisted Grounded Junction
K08I-000XX-000-0-00	Type K, 8 Gauge, Single, Standard Limits, Twisted Grounded Junction
K08O-000XX-000-0-00	Type K, 8 Gauge, Single, Standard Limits, Twisted Grounded Junction, No Insulators
K092-000XX-000-0-00	Type K, 8 Gauge, Single, Special Limits, Twisted Ungrounded Junction
K093-000XX-000-0-00	Type K, 8 Gauge, Single, Special Limits, Butt Welded Grounded Junction
K094-000XX-000-0-00	Type K, 8 Gauge, Single, Special Limits, Butt Welded Ungrounded Junction
K095-000XX-000-0-00	Type K, 8 Gauge, Dual, Special Limits, Common Ungrounded Junction
K096-000XX-000-0-00	Type K, 8 Gauge, Dual, Special Limits, Isolated Ungrounded Junction
K09H-000XX-000-0-00	Type K, 8 Gauge, Dual, Special Limits, Twisted Grounded Junction
K09I-000XX-000-0-00	Type K, 8 Gauge, Single, Special Limits, Twisted Grounded Junction
K09O-000XX-000-0-00	Type K, 8 Gauge, Single, Special Limits, Twisted Grounded Junction, No Insulators
K142-000XX-000-0-00	Type K, 14 Gauge, Single, Standard Limits, Twisted Ungrounded Junction
K143-000XX-000-0-00	Type K, 14 Gauge, Single, Standard Limits, Butt Welded Grounded Junction
K144-000XX-000-0-00	Type K, 14 Gauge, Single, Standard Limits, Butt Welded Ungrounded Junction
K145-000XX-000-0-00	Type K, 14 Gauge, Dual, Standard Limits, Common Ungrounded Junction
K146-000XX-000-0-00	Type K, 14 Gauge, Dual, Standard Limits, Isolated Ungrounded Junction
K14H-000XX-000-0-00	Type K, 14 Gauge, Dual, Standard Limits, Twisted Grounded Junction
K14I-000XX-000-0-00	Type K, 14 Gauge, Single, Standard Limits, Twisted Grounded Junction
K14O-000XX-000-0-00	Type K, 14 Gauge, Single, Standard Limits, Twisted Grounded Junction, No Insulators
K152-000XX-000-0-00	Type K, 14 Gauge, Single, Special Limits, Twisted Ungrounded Junction
K153-000XX-000-0-00	Type K, 14 Gauge, Single, Special Limits, Butt Welded Grounded Junction
K154-000XX-000-0-00	Type K, 14 Gauge, Single, Special Limits, Butt Welded Ungrounded Junction

T/C Elements

T/C Element Table (continued)

Straight Elements ("I" is the letter "I," not the numeral "1.")

K155-000XX-000-0-00	Type K, 14 Gauge, Dual, Special Limits, Common Ungrounded Junction
K156-000XX-000-0-00	Type K, 14 Gauge, Dual, Special Limits, Isolated Ungrounded Junction
K15H-000XX-000-0-00	Type K, 14 Gauge, Dual, Special Limits, Twisted Grounded Junction
K15I-000XX-000-0-00	Type K, 14 Gauge, Single, Special Limits, Twisted Grounded Junction
K15O-000XX-000-0-00	Type K, 14 Gauge, Single, Special Limits, Twisted Grounded Junction, No Insulators
K202-000XX-000-0-00	Type K, 20 Gauge, Single, Standard Limits, Twisted Ungrounded Junction
K203-000XX-000-0-00	Type K, 20 Gauge, Single, Standard Limits, Butt Welded Grounded Junction
K204-000XX-000-0-00	Type K, 20 Gauge, Single, Standard Limits, Butt Welded Ungrounded Junction
K205-000XX-000-0-00	Type K, 20 Gauge, Dual, Standard Limits, Common Ungrounded Junction
K206-000XX-000-0-00	Type K, 20 Gauge, Dual, Standard Limits, Isolated Ungrounded Junction
K20H-000XX-000-0-00	Type K, 20 Gauge, Dual, Standard Limits, Twisted Grounded Junction
K20I-000XX-000-0-00	Type K, 20 Gauge, Single, Standard Limits, Twisted Grounded Junction
K20O-000XX-000-0-00	Type K, 20 Gauge, Single, Standard Limits, Twisted Grounded Junction, No Insulators
K212-000XX-000-0-00	Type K, 20 Gauge, Single, Special Limits, Twisted Ungrounded Junction
K213-000XX-000-0-00	Type K, 20 Gauge, Single, Special Limits, Butt Welded Grounded Junction
K214-000XX-000-0-00	Type K, 20 Gauge, Single, Special Limits, Butt Welded Ungrounded Junction
K215-000XX-000-0-00	Type K, 20 Gauge, Dual, Special Limits, Common Ungrounded Junction
K216-000XX-000-0-00	Type K, 20 Gauge, Dual, Special Limits, Isolated Ungrounded Junction
K21H-000XX-000-0-00	Type K, 20 Gauge, Dual, Special Limits, Twisted Grounded Junction
K21I-000XX-000-0-00	Type K, 20 Gauge, Single, Special Limits, Twisted Grounded Junction
K21O-000XX-000-0-00	Type K, 20 Gauge, Single, Special Limits, Twisted Grounded Junction, No Insulators
T142-000XX-000-0-00	Type T, 14 Gauge, Single, Standard Limits, Twisted Ungrounded Junction
T143-000XX-000-0-00	Type T, 14 Gauge, Single, Standard Limits, Butt Welded Grounded Junction
T144-000XX-000-0-00	Type T, 14 Gauge, Single, Standard Limits, Butt Welded Ungrounded Junction
T145-000XX-000-0-00	Type T, 14 Gauge, Dual, Standard Limits, Common Ungrounded Junction
T146-000XX-000-0-00	Type T, 14 Gauge, Dual, Standard Limits, Isolated Ungrounded Junction
T14H-000XX-000-0-00	Type T, 14 Gauge, Dual, Standard Limits, Twisted Grounded Junction
T14I-000XX-000-0-00	Type T, 14 Gauge, Single, Standard Limits, Twisted Grounded Junction
T14O-000XX-000-0-00	Type T, 14 Gauge, Single, Standard Limits, Twisted Grounded Junction, No Insulators
T152-000XX-000-0-00	Type T, 14 Gauge, Single, Special Limits, Twisted Ungrounded Junction
T153-000XX-000-0-00	Type T, 14 Gauge, Single, Special Limits, Butt Welded Grounded Junction
T154-000XX-000-0-00	Type T, 14 Gauge, Single, Special Limits, Butt Welded Ungrounded Junction
T155-000XX-000-0-00	Type T, 14 Gauge, Dual, Special Limits, Common Ungrounded Junction
T156-000XX-000-0-00	Type T, 14 Gauge, Dual, Special Limits, Isolated Ungrounded Junction
T15H-000XX-000-0-00	Type T, 14 Gauge, Dual, Special Limits, Twisted Grounded Junction
T15I-000XX-000-0-00	Type T, 14 Gauge, Single, Special Limits, Twisted Grounded Junction
T15O-000XX-000-0-00	Type T, 14 Gauge, Single, Special Limits, Twisted Grounded Junction, No Insulators
T202-000XX-000-0-00	Type T, 20 Gauge, Single, Standard Limits, Twisted Ungrounded Junction
T203-000XX-000-0-00	Type T, 20 Gauge, Single, Standard Limits, Butt Welded Grounded Junction
T204-000XX-000-0-00	Type T, 20 Gauge, Single, Standard Limits, Butt Welded Ungrounded Junction
T205-000XX-000-0-00	Type T, 20 Gauge, Dual, Standard Limits, Common Ungrounded Junction
T206-000XX-000-0-00	Type T, 20 Gauge, Dual, Standard Limits, Isolated Ungrounded Junction
T20H-000XX-000-0-00	Type T, 20 Gauge, Dual, Standard Limits, Twisted Grounded Junction
T20I-000XX-000-0-00	Type T, 20 Gauge, Single, Standard Limits, Twisted Grounded Junction
T20O-000XX-000-0-00	Type T, 20 Gauge, Single, Standard Limits, Twisted Grounded Junction, No Insulators
T212-000XX-000-0-00	Type T, 20 Gauge, Single, Special Limits, Twisted Ungrounded Junction
T213-000XX-000-0-00	Type T, 20 Gauge, Single, Special Limits, Butt Welded Grounded Junction
T214-000XX-000-0-00	Type T, 20 Gauge, Single, Special Limits, Butt Welded Ungrounded Junction
T215-000XX-000-0-00	Type T, 20 Gauge, Dual, Special Limits, Common Ungrounded Junction
T216-000XX-000-0-00	Type T, 20 Gauge, Dual, Special Limits, Isolated Ungrounded Junction
T21H-000XX-000-0-00	Type T, 20 Gauge, Dual, Special Limits, Twisted Grounded Junction
T21I-000XX-000-0-00	Type T, 20 Gauge, Single, Special Limits, Twisted Grounded Junction
T21O-000XX-000-0-00	Type T, 20 Gauge, Single, Special Limits, Twisted Grounded Junction, No Insulators

T/C Elements

T/C Element Table (continued)

90° Elements ("I" is the letter "I," not the numeral "1.")

 To obtain total length, add hot leg (Fields 8, 9) and cold leg (Fields 11, 12)

E14C-000XX-0YY-000-0-00	Type E, 14 Gauge, Single, Standard Limits, Twisted Ungrounded Junction
E14E-000XX-0YY-000-0-00	Type E, 14 Gauge, Single, Standard Limits, Butt Welded Grounded Junction
E14F-000XX-0YY-000-0-00	Type E, 14 Gauge, Single, Standard Limits, Butt Welded Ungrounded Junction
E14G-000XX-0YY-000-0-00	Type E, 14 Gauge, Dual, Standard Limits, Common Ungrounded Junction
E14J-000XX-0YY-000-0-00	Type E, 14 Gauge, Dual, Standard Limits, Twisted Grounded Junction
E14L-000XX-0YY-000-0-00	Type E, 14 Gauge, Single, Standard Limits, Twisted Grounded Junction
E14M-000XX-0YY-000-0-00	Type E, 14 Gauge, Dual, Standard Limits, Isolated Ungrounded Junction
E15C-000XX-0YY-000-0-00	Type E, 14 Gauge, Single, Special Limits, Twisted Ungrounded Junction
E15E-000XX-0YY-000-0-00	Type E, 14 Gauge, Single, Special Limits, Butt Welded Grounded Junction
E15F-000XX-0YY-000-0-00	Type E, 14 Gauge, Single, Special Limits, Butt Welded Ungrounded Junction
E15G-000XX-0YY-000-0-00	Type E, 14 Gauge, Dual, Special Limits, Common Ungrounded Junction
E15J-000XX-0YY-000-0-00	Type E, 14 Gauge, Dual, Special Limits, Twisted Grounded Junction
E15L-000XX-0YY-000-0-00	Type E, 14 Gauge, Single, Special Limits, Twisted Grounded Junction
E15M-000XX-0YY-000-0-00	Type E, 14 Gauge, Dual, Special Limits, Isolated Ungrounded Junction
E20C-000XX-0YY-000-0-00	Type E, 20 Gauge, Single, Standard Limits, Twisted Ungrounded Junction
E20E-000XX-0YY-000-0-00	Type E, 20 Gauge, Single, Standard Limits, Butt Welded Grounded Junction
E20F-000XX-0YY-000-0-00	Type E, 20 Gauge, Single, Standard Limits, Butt Welded Ungrounded Junction
E20G-000XX-0YY-000-0-00	Type E, 20 Gauge, Dual, Standard Limits, Common Ungrounded Junction
E20J-000XX-0YY-000-0-00	Type E, 20 Gauge, Dual, Standard Limits, Twisted Grounded Junction
E20L-000XX-0YY-000-0-00	Type E, 20 Gauge, Single, Standard Limits, Twisted Grounded Junction
E20M-000XX-0YY-000-0-00	Type E, 20 Gauge, Dual, Standard Limits, Isolated Ungrounded Junction
E21C-000XX-0YY-000-0-00	Type E, 20 Gauge, Single, Special Limits, Twisted Ungrounded Junction
E21E-000XX-0YY-000-0-00	Type E, 20 Gauge, Single, Special Limits, Butt Welded Grounded Junction
E21F-000XX-0YY-000-0-00	Type E, 20 Gauge, Single, Special Limits, Butt Welded Ungrounded Junction
E21G-000XX-0YY-000-0-00	Type E, 20 Gauge, Dual, Special Limits, Common Ungrounded Junction
E21J-000XX-0YY-000-0-00	Type E, 20 Gauge, Dual, Special Limits, Twisted Grounded Junction
E21L-000XX-0YY-000-0-00	Type E, 20 Gauge, Single, Special Limits, Twisted Grounded Junction
E21M-000XX-0YY-000-0-00	Type E, 20 Gauge, Dual, Special Limits, Isolated Ungrounded Junction
J08C-000XX-0YY-000-0-00	Type J, 8 Gauge, Single, Standard Limits, Twisted Ungrounded Junction
J08E-000XX-0YY-000-0-00	Type J, 8 Gauge, Single, Standard Limits, Butt Welded Grounded Junction
J08F-000XX-0YY-000-0-00	Type J, 8 Gauge, Single, Standard Limits, Butt Welded Ungrounded Junction
J08G-000XX-0YY-000-0-00	Type J, 8 Gauge, Dual, Standard Limits, Common Ungrounded Junction
J08J-000XX-0YY-000-0-00	Type J, 8 Gauge, Dual, Standard Limits, Twisted Grounded Junction
J08L-000XX-0YY-000-0-00	Type J, 8 Gauge, Single, Standard Limits, Twisted Grounded Junction
J08M-000XX-0YY-000-0-00	Type J, 8 Gauge, Dual, Standard Limits, Isolated Ungrounded Junction
J09C-000XX-0YY-000-0-00	Type J, 8 Gauge, Single, Special Limits, Twisted Ungrounded Junction
J09E-000XX-0YY-000-0-00	Type J, 8 Gauge, Single, Special Limits, Butt Welded Grounded Junction
J09F-000XX-0YY-000-0-00	Type J, 8 Gauge, Single, Special Limits, Butt Welded Ungrounded Junction
J09G-000XX-0YY-000-0-00	Type J, 8 Gauge, Dual, Special Limits, Common Ungrounded Junction
J09J-000XX-0YY-000-0-00	Type J, 8 Gauge, Dual, Special Limits, Twisted Grounded Junction
J09L-000XX-0YY-000-0-00	Type J, 8 Gauge, Single, Special Limits, Twisted Grounded Junction
J09M-000XX-0YY-000-0-00	Type J, 8 Gauge, Dual, Special Limits, Isolated Ungrounded Junction
J14C-000XX-0YY-000-0-00	Type J, 14 Gauge, Single, Standard Limits, Twisted Ungrounded Junction
J14E-000XX-0YY-000-0-00	Type J, 14 Gauge, Single, Standard Limits, Butt Welded Grounded Junction
J14F-000XX-0YY-000-0-00	Type J, 14 Gauge, Single, Standard Limits, Butt Welded Ungrounded Junction
J14G-000XX-0YY-000-0-00	Type J, 14 Gauge, Dual, Standard Limits, Common Ungrounded Junction
J14J-000XX-0YY-000-0-00	Type J, 14 Gauge, Dual, Standard Limits, Twisted Grounded Junction
J14L-000XX-0YY-000-0-00	Type J, 14 Gauge, Single, Standard Limits, Twisted Grounded Junction
J14M-000XX-0YY-000-0-00	Type J, 14 Gauge, Dual, Standard Limits, Isolated Ungrounded Junction

T/C Elements

T/C Element Table (continued)

90° Elements (“I” is the letter “I,” not the numeral “1.”)

 To obtain total length, add hot leg (Fields 8, 9) and cold leg (Fields 11, 12)

J15C-000XX-0YY-000-0-00	Type J, 14 Gauge, Single, Special Limits, Twisted Ungrounded Junction
J15E-000XX-0YY-000-0-00	Type J, 14 Gauge, Single, Special Limits, Butt Welded Grounded Junction
J15F-000XX-0YY-000-0-00	Type J, 14 Gauge, Single, Special Limits, Butt Welded Ungrounded Junction
J15G-000XX-0YY-000-0-00	Type J, 14 Gauge, Dual, Special Limits, Common Ungrounded Junction
J15J-000XX-0YY-000-0-00	Type J, 14 Gauge, Dual, Special Limits, Twisted Grounded Junction
J15L-000XX-0YY-000-0-00	Type J, 14 Gauge, Single, Special Limits, Twisted Grounded Junction
J15M-000XX-0YY-000-0-00	Type J, 14 Gauge, Dual, Special Limits, Isolated Ungrounded Junction
J20C-000XX-0YY-000-0-00	Type J, 20 Gauge, Single, Standard Limits, Twisted Ungrounded Junction
J20E-000XX-0YY-000-0-00	Type J, 20 Gauge, Single, Standard Limits, Butt Welded Grounded Junction
J20F-000XX-0YY-000-0-00	Type J, 20 Gauge, Single, Standard Limits, Butt Welded Ungrounded Junction
J20G-000XX-0YY-000-0-00	Type J, 20 Gauge, Dual, Standard Limits, Common Ungrounded Junction
J20J-000XX-0YY-000-0-00	Type J, 20 Gauge, Dual, Standard Limits, Twisted Grounded Junction
J20L-000XX-0YY-000-0-00	Type J, 20 Gauge, Single, Standard Limits, Twisted Grounded Junction
J20M-000XX-0YY-000-0-00	Type J, 20 Gauge, Dual, Standard Limits, Isolated Ungrounded Junction
J21C-000XX-0YY-000-0-00	Type J, 20 Gauge, Single, Special Limits, Twisted Ungrounded Junction
J21E-000XX-0YY-000-0-00	Type J, 20 Gauge, Single, Special Limits, Butt Welded Grounded Junction
J21F-000XX-0YY-000-0-00	Type J, 20 Gauge, Single, Special Limits, Butt Welded Ungrounded Junction
J21G-000XX-0YY-000-0-00	Type J, 20 Gauge, Dual, Special Limits, Common Ungrounded Junction
J21J-000XX-0YY-000-0-00	Type J, 20 Gauge, Dual, Special Limits, Twisted Grounded Junction
J21L-000XX-0YY-000-0-00	Type J, 20 Gauge, Single, Special Limits, Twisted Grounded Junction
J21M-000XX-0YY-000-0-00	Type J, 20 Gauge, Dual, Special Limits, Isolated Ungrounded Junction
K08C-000XX-0YY-000-0-00	Type K, 8 Gauge, Single, Standard Limits, Twisted Ungrounded Junction
K08E-000XX-0YY-000-0-00	Type K, 8 Gauge, Single, Standard Limits, Butt Welded Grounded Junction
K08F-000XX-0YY-000-0-00	Type K, 8 Gauge, Single, Standard Limits, Butt Welded Ungrounded Junction
K08G-000XX-0YY-000-0-00	Type K, 8 Gauge, Dual, Standard Limits, Common Ungrounded Junction
K08J-000XX-0YY-000-0-00	Type K, 8 Gauge, Dual, Standard Limits, Twisted Grounded Junction
K08L-000XX-0YY-000-0-00	Type K, 8 Gauge, Single, Standard Limits, Twisted Grounded Junction
K08M-000XX-0YY-000-0-00	Type K, 8 Gauge, Dual, Standard Limits, Isolated Ungrounded Junction
K09C-000XX-0YY-000-0-00	Type K, 8 Gauge, Single, Special Limits, Twisted Ungrounded Junction
K09E-000XX-0YY-000-0-00	Type K, 8 Gauge, Single, Special Limits, Butt Welded Grounded Junction
K09F-000XX-0YY-000-0-00	Type K, 8 Gauge, Single, Special Limits, Butt Welded Ungrounded Junction
K09G-000XX-0YY-000-0-00	Type K, 8 Gauge, Dual, Special Limits, Common Ungrounded Junction
K09J-000XX-0YY-000-0-00	Type K, 8 Gauge, Dual, Special Limits, Twisted Grounded Junction
K09L-000XX-0YY-000-0-00	Type K, 8 Gauge, Single, Special Limits, Twisted Grounded Junction
K09M-000XX-0YY-000-0-00	Type K, 8 Gauge, Dual, Special Limits, Isolated Ungrounded Junction
K14C-000XX-0YY-000-0-00	Type K, 14 Gauge, Single, Standard Limits, Twisted Ungrounded Junction
K14E-000XX-0YY-000-0-00	Type K, 14 Gauge, Single, Standard Limits, Butt Welded Grounded Junction
K14F-000XX-0YY-000-0-00	Type K, 14 Gauge, Single, Standard Limits, Butt Welded Ungrounded Junction
K14G-000XX-0YY-000-0-00	Type K, 14 Gauge, Dual, Standard Limits, Common Ungrounded Junction
K14J-000XX-0YY-000-0-00	Type K, 14 Gauge, Dual, Standard Limits, Twisted Grounded Junction
K14L-000XX-0YY-000-0-00	Type K, 14 Gauge, Single, Standard Limits, Twisted Grounded Junction
K14M-000XX-0YY-000-0-00	Type K, 14 Gauge, Dual, Standard Limits, Isolated Ungrounded Junction
K15C-000XX-0YY-000-0-00	Type K, 14 Gauge, Single, Special Limits, Twisted Ungrounded Junction
K15E-000XX-0YY-000-0-00	Type K, 14 Gauge, Single, Special Limits, Butt Welded Grounded Junction
K15F-000XX-0YY-000-0-00	Type K, 14 Gauge, Single, Special Limits, Butt Welded Ungrounded Junction
K15G-000XX-0YY-000-0-00	Type K, 14 Gauge, Dual, Special Limits, Common Ungrounded Junction
K15J-000XX-0YY-000-0-00	Type K, 14 Gauge, Dual, Special Limits, Twisted Grounded Junction
K15L-000XX-0YY-000-0-00	Type K, 14 Gauge, Single, Special Limits, Twisted Grounded Junction
K15M-000XX-0YY-000-0-00	Type K, 14 Gauge, Dual, Special Limits, Isolated Ungrounded Junction

T/C Elements

T/C Element Table (continued)

90° Elements (“I” is the letter “I,” not the numeral “1.”)

 To obtain total length, add hot leg (Fields 8, 9) and cold leg (Fields 11, 12)

K20C-000XX-0YY-000-0-00	Type K, 20 Gauge, Single, Standard Limits, Twisted Ungrounded Junction
K20E-000XX-0YY-000-0-00	Type K, 20 Gauge, Single, Standard Limits, Butt Welded Grounded Junction
K20F-000XX-0YY-000-0-00	Type K, 20 Gauge, Single, Standard Limits, Butt Welded Ungrounded Junction
K20G-000XX-0YY-000-0-00	Type K, 20 Gauge, Dual, Standard Limits, Common Ungrounded Junction
K20J-000XX-0YY-000-0-00	Type K, 20 Gauge, Dual, Standard Limits, Twisted Grounded Junction
K20L-000XX-0YY-000-0-00	Type K, 20 Gauge, Single, Standard Limits, Twisted Grounded Junction
K20M-000XX-0YY-000-0-00	Type K, 20 Gauge, Dual, Standard Limits, Isolated Ungrounded Junction
K21C-000XX-0YY-000-0-00	Type K, 20 Gauge, Single, Special Limits, Twisted Ungrounded Junction
K21E-000XX-0YY-000-0-00	Type K, 20 Gauge, Single, Special Limits, Butt Welded Grounded Junction
K21F-000XX-0YY-000-0-00	Type K, 20 Gauge, Single, Special Limits, Butt Welded Ungrounded Junction
K21G-000XX-0YY-000-0-00	Type K, 20 Gauge, Dual, Special Limits, Common Ungrounded Junction
K21J-000XX-0YY-000-0-00	Type K, 20 Gauge, Dual, Special Limits, Twisted Grounded Junction
K21L-000XX-0YY-000-0-00	Type K, 20 Gauge, Single, Special Limits, Twisted Grounded Junction
K21M-000XX-0YY-000-0-00	Type K, 20 Gauge, Dual, Special Limits, Isolated Ungrounded Junction
T14C-000XX-0YY-000-0-00	Type T, 14 Gauge, Single, Standard Limits, Twisted Ungrounded Junction
T14E-000XX-0YY-000-0-00	Type T, 14 Gauge, Single, Standard Limits, Butt Welded Grounded Junction
T14F-000XX-0YY-000-0-00	Type T, 14 Gauge, Single, Standard Limits, Butt Welded Ungrounded Junction
T14G-000XX-0YY-000-0-00	Type T, 14 Gauge, Dual, Standard Limits, Common Ungrounded Junction
T14J-000XX-0YY-000-0-00	Type T, 14 Gauge, Dual, Standard Limits, Twisted Grounded Junction
T14L-000XX-0YY-000-0-00	Type T, 14 Gauge, Single, Standard Limits, Twisted Grounded Junction
T14M-000XX-0YY-000-0-00	Type T, 14 Gauge, Dual, Standard Limits, Isolated Ungrounded Junction
T15C-000XX-0YY-000-0-00	Type T, 14 Gauge, Single, Special Limits, Twisted Ungrounded Junction
T15E-000XX-0YY-000-0-00	Type T, 14 Gauge, Single, Special Limits, Butt Welded Grounded Junction
T15F-000XX-0YY-000-0-00	Type T, 14 Gauge, Single, Special Limits, Butt Welded Ungrounded Junction
T15G-000XX-0YY-000-0-00	Type T, 14 Gauge, Dual, Special Limits, Common Ungrounded Junction
T15J-000XX-0YY-000-0-00	Type T, 14 Gauge, Dual, Special Limits, Twisted Grounded Junction
T15L-000XX-0YY-000-0-00	Type T, 14 Gauge, Single, Special Limits, Twisted Grounded Junction
T15M-000XX-0YY-000-0-00	Type T, 14 Gauge, Dual, Special Limits, Isolated Ungrounded Junction
T20C-000XX-0YY-000-0-00	Type T, 20 Gauge, Single, Standard Limits, Twisted Ungrounded Junction
T20E-000XX-0YY-000-0-00	Type T, 20 Gauge, Single, Standard Limits, Butt Welded Grounded Junction
T20F-000XX-0YY-000-0-00	Type T, 20 Gauge, Single, Standard Limits, Butt Welded Ungrounded Junction
T20G-000XX-0YY-000-0-00	Type T, 20 Gauge, Dual, Standard Limits, Common Ungrounded Junction
T20J-000XX-0YY-000-0-00	Type T, 20 Gauge, Dual, Standard Limits, Twisted Grounded Junction
T20L-000XX-0YY-000-0-00	Type T, 20 Gauge, Single, Standard Limits, Twisted Grounded Junction
T20M-000XX-0YY-000-0-00	Type T, 20 Gauge, Dual, Standard Limits, Isolated Ungrounded Junction
T21C-000XX-0YY-000-0-00	Type T, 20 Gauge, Single, Special Limits, Twisted Ungrounded Junction
T21E-000XX-0YY-000-0-00	Type T, 20 Gauge, Single, Special Limits, Butt Welded Grounded Junction
T21F-000XX-0YY-000-0-00	Type T, 20 Gauge, Single, Special Limits, Butt Welded Ungrounded Junction
T21G-000XX-0YY-000-0-00	Type T, 20 Gauge, Dual, Special Limits, Common Ungrounded Junction
T21J-000XX-0YY-000-0-00	Type T, 20 Gauge, Dual, Special Limits, Twisted Grounded Junction
T21L-000XX-0YY-000-0-00	Type T, 20 Gauge, Single, Special Limits, Twisted Grounded Junction
T21M-000XX-0YY-000-0-00	Type T, 20 Gauge, Dual, Special Limits, Isolated Ungrounded Junction

T/C Elements

Thermocouple Elements Special Assemblies

Introduction

Code 24, 30 Tubes

Element is insulated with a single hole 51-009 insulator on the positive leg only.

Code 41, 42 Tubes

Straight elements: Leads have approximately 2" of insulating beads at cold end to provide flexibility required by ceramic coated steel tubes (code 42). 8 gauge element uses 51-052 insulators.

90° Elements: Code 41 protection tube requires a special 8 gauge element because of its small inside diameter. Code 42 protection tube requires special elements because of the spring extension which requires a bead section about 10" long.

Ordering Information

Complete this model number.

Model No. 0 0 0 A - - - -

Field No. 1 2 3 4 5 6 7 8 9 10 11 12 13 14 15

Fields 1 through 3. RESERVED

Fields 4 through 9. BASE MODEL

Specify Field 13 first

		Fields 4 through 9			
		Straight		90°	
Field 13	Tube	Single	Dual	Single	Dual
1	24 or 30	A-11727			
	41	A-11888	A-11712	A-11809	
	42	A-11711		A-10462	
2 or 3	41	A-11888		A-11809	A-10504
	42	A-11711	A-11712	A-10462	

Field 10. THERMOCOUPLE TYPE

- 1 - Type J
- 2 - Type K
- 3 - Type E
- 4 - Type T

Fields 11, 12. HOT LENGTH (DIMENSION "HL")

- XX - Specify in whole inches

Field 13. WIRE GAUGE

- 1 - 8 gauge
- 2 - 14 gauge
- 3 - 20 gauge

**Fields 14, 15. LIMITS OF ERROR (FOR STRAIGHT TUBES) OR
COLD LENGTH (DIMENSION "CL" FOR 90° TUBES)**

Straight Tubes

- 00 - Standard limits of error
- 01 - Special limits of error

90° Tubes

- XX - Specify "CL" dimension in whole inches

T/C Elements

Special Elements Table

 To obtain total length, add HL (Fields 11, 12) and CL (Fields 14, 15 – 90° only)

A-10462

90° elements for use with protection tube code 42

A-10462-1HL -1-CL	Type J, 8 gauge	standard limits
A-10462-1HL -2-CL	Type J, 14 gauge	standard limits
A-10462-1HL -3-CL	Type J, 20 gauge	standard limits
A-10462-2HL -1-CL	Type K, 8 gauge	standard limits
A-10462-2HL -2-CL	Type K, 14 gauge	standard limits
A-10462-2HL -3-CL	Type K, 20 gauge	standard limits
A-10462-3HL -1-CL	Type E, 8 gauge	standard limits
A-10462-3HL -2-CL	Type E, 14 gauge	standard limits
A-10462-3HL -3-CL	Type E, 20 gauge	standard limits
A-10462-4HL -2-CL	Type T, 14 gauge	standard limits (Obsolete)
A-10462-4HL -3-CL	Type T, 20 gauge	standard limits (Obsolete)

A-10504

90° dual elements for use with protection tube codes 41 and 42

A-10504-1HL -2-CL	Type J, 14 gauge	standard limits
A-10504-1HL -3-CL	Type J, 20 gauge	standard limits
A-10504-2HL -2-CL	Type K, 14 gauge	standard limits
A-10504-2HL -3-CL	Type K, 20 gauge	standard limits
A-10504-3HL -2-CL	Type E, 14 gauge	standard limits
A-10504-4HL -2-CL	Type T, 14 gauge	standard limits (Obsolete)
A-10504-4HL -3-CL	Type T, 20 gauge	standard limits (Obsolete)

A-11711

Straight elements for use with protection tube code 42

A-11711-1HL-1-00	Type J, 8 gauge	standard limits
A-11711-1HL-2-00	Type J, 14 gauge	standard limits
A-11711-1HL-3-00	Type J, 20 gauge	standard limits
A-11711-2HL-1-00	Type K, 8 gauge	standard limits
A-11711-2HL-2-00	Type K, 14 gauge	standard limits
A-11711-2HL-3-00	Type K, 20 gauge	standard limits
A-11711-3HL-1-00	Type E, 8 gauge	standard limits
A-11711-3HL-2-00	Type E, 14 gauge	standard limits
A-11711-3HL-3-00	Type E, 20 gauge	standard limits
A-11711-4HL-2-00	Type T, 14 gauge	standard limits (Obsolete)
A-11711-4HL-3-00	Type T, 20 gauge	standard limits (Obsolete)

A-11712

Straight dual elements for use with protection tube codes 41 and 42

A-11712-1HL-1-00	Type J, 8 gauge	standard limits
A-11712-1HL-2-00	Type J, 14 gauge	standard limits
A-11712-1HL-3-00	Type J, 20 gauge	standard limits
A-11712-2HL-1-00	Type K, 8 gauge	standard limits
A-11712-2HL-2-00	Type K, 14 gauge	standard limits
A-11712-2HL-3-00	Type K, 20 gauge	standard limits
A-11712-3HL-1-00	Type E, 8 gauge	standard limits
A-11712-3HL-2-00	Type E, 14 gauge	standard limits
A-11712-3HL-3-00	Type E, 20 gauge	standard limits
A-11712-4HL-2-00	Type T, 14 gauge	standard limits (Obsolete)
A-11712-4HL-3-00	Type T, 20 gauge	standard limits (Obsolete)

T/C Elements

Special Elements Table (continued)

A-11727

8 gauge elements for use with protection tube codes 24 and 30	A-11727-1HL-1-00	Type J, 8 gauge	standard limits
	A-11727-2HL-1-00	Type K, 8 gauge	standard limits
	A-11727-3HL-1-00	Type E, 8 gauge	standard limits

A-11809

90° elements for use with protection tube code 41	A-11809-1HL-1-CL	Type J, 8 gauge	standard limits
	A-11809-1HL-2-CL	Type J, 14 gauge	standard limits
	A-11809-1HL-3-CL	Type J, 20 gauge	standard limits
	A-11809-2HL-1-CL	Type K, 8 gauge	standard limits
	A-11809-2HL-2-CL	Type K, 14 gauge	standard limits
	A-11809-2HL-3-CL	Type K, 20 gauge	standard limits
	A-11809-3HL-1-CL	Type E, 8 gauge	standard limits
	A-11809-3HL-2-CL	Type E, 14 gauge	standard limits
	A-11809-3HL-3-CL	Type E, 20 gauge	standard limits
	A-11809-4HL-2-CL	Type T, 14 gauge	standard limits (Obsolete)
A-11809-4HL-3-CL	Type T, 20 gauge	standard limits (Obsolete)	

A-11888

Straight elements for use with protection tube code 41	A-11888-1HL-1-00	Type J, 8 gauge	standard limits
	A-11888-1HL-2-00	Type J, 14 gauge	standard limits
	A-11888-1HL-3-00	Type J, 20 gauge	standard limits
	A-11888-2HL-1-00	Type K, 8 gauge	standard limits
	A-11888-2HL-2-00	Type K, 14 gauge	standard limits
	A-11888-2HL-3-00	Type K, 20 gauge	standard limits
	A-11888-3HL-1-00	Type E, 8 gauge	standard limits
	A-11888-3HL-2-00	Type E, 14 gauge	standard limits
	A-11888-3HL-3-00	Type E, 20 gauge	standard limits
	A-11888-4HL-2-00	Type T, 14 gauge	standard limits (Obsolete)
A-11888-4HL-3-00	Type T, 20 gauge	standard limits (Obsolete)	

T/C Elements

Noble Metal and Other High Temperature Thermocouple Elements

Introduction

The elements consist of standardized and matched wires, individually checked. The hot junctions of noble metal elements are end contact welded. Cold ends are terminated with butt connectors.

Both bare elements and insulated elements are available. The positive lead of an insulated element is identified with a colored glass bead as follows: Type R - blue or black; type S - clear; type B - yellow; type F - yellow and blue or black; and, type C - green. Insulated elements are for use with general purpose or weatherproof heads.

Contamination

Platinum and platinum alloy thermocouple wire is extremely susceptible to contamination from elements such as silicon, iron, zinc, calcium, etc. Keep platinum and platinum alloy thermocouple wire clean both before and during use. Contamination causes negative direction drift and weakening of the wire.

Ordering Information

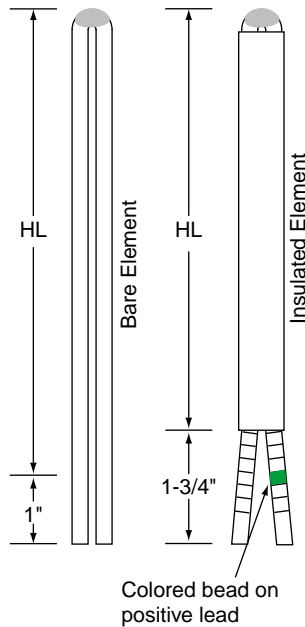

Note: "1" is the letter "I," not the numeral "1."

Complete this model number.

Model No. - 0 0 0 - 0 0 0 - 0 - 0 0
 Field No. 1 2 3 4 5 6 7 8 9 10 11 12 13 14 15

Field 1. THERMOCOUPLE TYPE

- R - Platinum, 13% Rhodium - Platinum
- S - Platinum, 10% Rhodium - Platinum
- B - Platinum, 30% Rhodium - Platinum, 6% Rhodium
- C - Tungsten, 5% Rhenium - Tungsten, 26% Rhenium

Fields 2, 3. WIRE GAUGE; LIMITS OF ERROR

- See compatibility table at front of Industrial Sensors section
- 24 - 24 gauge, standard limits
 - 25 - 24 gauge, special limits (Types B, S, and R only)

Field 4. ELEMENT CONSTRUCTION

- I - Straight single element two hole ceramic insulators
- O - Bare wire element no insulators
- H - Straight dual element two hole ceramic insulators

Fields 5, 6, 7. RESERVED

Fields 8, 9. HOT LEG ("HL" DIMENSION)

- HL - Length "HL" in whole inches

Fields 10 through 15 RESERVED

T/C Elements

Noble Metal T/C Elements Table

Noble Metal Thermocouple Elements

Note: in this list
"l" is the letter "l,"
not the numeral "1."

B24H-000HL-000-0-00
B24l-000HL-000-0-00
B24O-000HL-000-0-00
B25H-000HL-000-0-00
B25l-000HL-000-0-00
B25O-000HL-000-0-00

C24H-000HL-000-0-00
C24l-000HL-000-0-00
C24O-000HL-000-0-00

R24H-000HL-000-0-00
R24l-000HL-000-0-00
R24O-000HL-000-0-00
R25H-000HL-000-0-00
R25l-000HL-000-0-00
R25O-000HL-000-0-00

S24H-000HL-000-0-00
S24l-000HL-000-0-00
S24O-000HL-000-0-00
S25H-000HL-000-0-00
S25l-000HL-000-0-00
S25O-000HL-000-0-00

T/C Elements

Noble Metal Thermocouples for Silicon Carbide Protection Tube Assemblies

Ordering Information

Complete this model number.

Model No. 0 0 0 A - **- 0 0 - 0 -**

Field No. 1 2 3 4 5 6 7 8 9 10 11 12 13 14 15

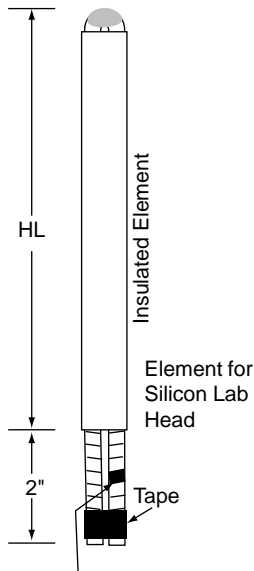

Colored bead on positive lead

Fields 1 through 3. RESERVED

Fields 4 through 9. BASE MODEL

For Silicon Carbide Protection Tube Assemblies

A-11670 - 24 gauge, single element, standard limits

A-11675 - 24 gauge, dual element, standard limits

Field 10. THERMOCOUPLE TYPE

- 0 - Type R
- 1 - Type S
- 2 - Type B
- 3 - Type C

Fields 11, 12, 13. RESERVED

Fields 14, 15. HOT LEG (HL DIMENSION)

HL - "HL" length in whole inches

Silicon Carbide Protection Tube Assemblies

- A-11670-000-0-HL
- A-11670-100-0-HL
- A-11670-200-0-HL
- A-11670-300-0-HL
- A-11675-000-0-HL
- A-11675-100-0-HL
- A-11675-200-0-HL
- A-11675-300-0-HL

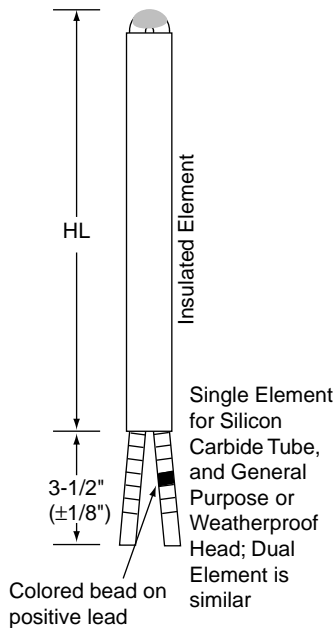

Colored bead on positive lead

Extensions

Extensions

Introduction

Extensions connect a thermocouple to an instrument. Types J and K extensions have 20 gauge, strand, fiberglass insulated wire. Types T, E and R/S are 20 gauge solid, with fiberglass insulation

Ordering Information

Model No. 0 0 0 A - - - -

Field No. 1 2 3 4 5 6 7 8 9 10 11 12 13 14 15

Fields 1 through 4. ASSEMBLY

000A - Assembly

Fields 5 through 9. BASE MODEL

Single Element with

- 07180 - Jack and junction box connector
- 07181 - Solid pin plug and box connector
- 13972 - Hollow pin plug and box connector
- 07182 - Solid pin plug and jack
- 13973 - Hollow pin plug and jack

Dual Element with

- 09254 - Jacks and junction box connector
- 09255 - Solid pin plugs and box connector
- 13975 - Hollow pin plugs and box connector
- 09256 - Solid pin plugs and jacks

Fields 10, 11, 12. TYPE

- 100 - Type J
- 200 - Type K
- 300 - Type R or S
- 400 - Type T
- 500 - Type E
- 600 - Uncompensated
- 700 - Three wire RTD

Fields 13, 14, 15. FLEXIBLE LENGTH ("Y" DIMENSION)

- Y-YY - "Y" dimension in whole inches – up to 99 inches.
- 9-99 - "Y" dimension 100 inches or greater. Specify on order.

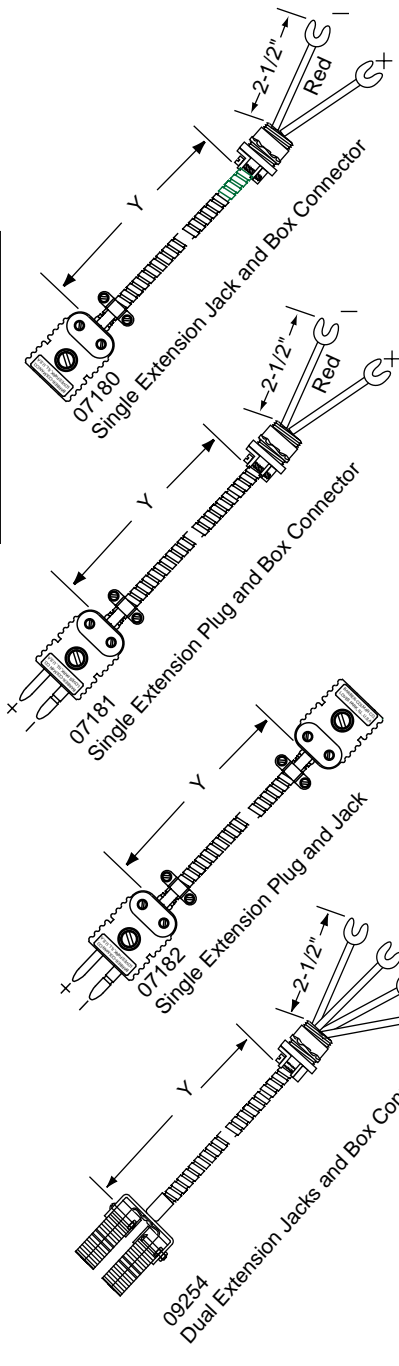

Insulators

Insulators

Introduction

Insulators are available in various materials and sizes to meet any thermocouple requirement. Operating temperatures and material compositions are shown under "specifications."

Mullite, Steatite and Cordierite are recommended only for base metal thermocouples.

Alumina

Recommended for noble metal thermocouples since there are few impurities to react with noble metal thermocouples at high temperatures. High physical strength. Good electrical properties. Fair resistance to thermal and electrical shock.

Mullite

Excellent high temperature material. Good thermal shock resistance. Low thermal expansion.

Steatite

High physical strength. Good electrical properties. Loses resistance at high temperatures. Poor heat shock resistance.

Cordierite

Excellent heat shock resistance. Fair physical strength and fair electrical properties.

Specifications

	Temp. (°F)		Chemical Composition							
	Useful	Max.	Al ₂ O ₃	SiO ₂	MgO	Na ₂ O	Fe ₂ O	CaO	K ₂ O	TiO ₂
Alumina	3400	3600	99.00	00.70	00.09	00.07	00.09	00.05	00.00	00.00
Mullite	3000	3200	55.40	42.00	00.04	00.46	00.80	00.10	00.70	00.50
Steatite	1850	2450	04.60	64.90	27.80	00.90	00.85	00.28	00.47	00.20
Cordierite	2050	2475	24.70	54.80	11.70	00.27	00.59	01.60	00.14	01.20

Ordering Information

In the following tables:

Wire = B&S gauge

Hole = Minimum/Maximum

O.D. = Outside diameter

L = (Length)

W = (Weight) = Number of ounces for ten pieces

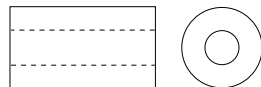

One Hole Round

Number	Wire	Material	Hole	O.D.	L	W
One Hole Round						
51-00009-000-0-00	8	Mullite	0.182"/0.192"	1/4"	3"	1
51-00014-000-0-00	14	Cordierite	0.083"/0.103"	9/64"	1"	1

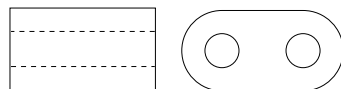

Two Hole Oval

Number	Wire	Material	Hole	O.D.	L	W
Two Hole Round						
51-00012-000-0-00	8	Cordierite	0.144"/0.164"	31/64"	1"	1/2
51-00018-000-0-00	14	Steatite	0.065"/0.085"	1/4"	1"	1/2
51-00019-000-0-00	14	Steatite	0.065"/0.085"	1/4"	6'	3
51-00021-000-0-00	14	Steatite	0.070"/0.090"	1/4"	2"	1
51-00022-000-0-00	14	Steatite	0.070"/0.090"	1/4"	3"	1-1/2
51-00056-000-0-00	15	Cordierite	0.062"/0.086"	1/4"	2-1/2"	1-1/2
51-00027-000-0-00	19	Steatite	0.038"/0.058"	5/32"	2-1/4"	1/2

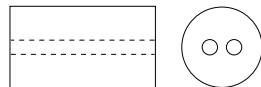

Two Hole Round

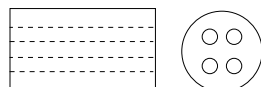

Four Hole Round

Insulators

Ordering Information (continued)

<u>Number</u>	<u>Wire</u>	<u>Material</u>	<u>Hole</u>	<u>O.D.</u>	<u>L</u>	<u>W</u>
Two Hole Round (continued)						
51-00031-000-0-00	20	Mullite	0.037"/0.043"	1/8"	6"	1-1/2"
51-00047-000-0-00	22	Alumina	0.037"/0.043"	1/8"	6"	1-1/2"
51-00060-000-0-00	22	Alumina	0.035"/0.045"	1/8"	35-1/2"	8"
51-00078-000-0-00	22	Alumina	0.035"/0.045"	1/8"	47-1/2"	

Two Hole Oval						
51-00003-000-0-00	6	Cordierite	0.181"/0.201"	5/16 x 9/16"	1"	1/2"
51-00006-000-0-00	7	Cordierite	0.158"/0.178"	9/32 x 31/64"	1"	1"
51-00008-000-0-00	7	Cordierite	0.153"/0.173"	9/32 x 31/64"	3"	1"
51-00013-000-0-00	11	Steatite	0.100"/0.110"	3/16 x 5/16"	1"	1/2"
51-00017-000-0-00	14	Cordierite	0.070"/0.090"	3/16 x 5/16"	1"	1/2"

Two Hole Oval - Special used in Code 14, 41 and 42 Protection Tubes

51-00062-000-0-00	8	Steatite	0.147"/0.153"	0.435 x 1/4"	1"	1"
-------------------	---	----------	---------------	--------------	----	----

Four Hole Round

51-00070-000-0-00	8	Cordierite	0.135"/0.150"	1/2"	1"	2"
51-00051-000-0-00	14	Steatite	0.068"/0.088"	5/16"	1"	1"
51-00052-000-0-00	20	Cordierite	0.036"/0.056"	3/16"	1"	1"
51-00064-000-0-00	24	Alumina	0.043"/0.051"	3/16"	17-1/2"	8"
51-00066-000-0-00	24	Alumina	0.043"/0.051"	3/16"	29-1/2"	14"
51-00067-000-0-00	24	Alumina	0.043"/0.051"	3/16"	35-1/2"	16"

Bead (Ball and Socket Style for "Fish Spine")

L = Approximate length per pound, in feet.

Q = Approximate quantity per pound.

O.D. = Outside Diameter and Length (Dimensions are equal).

<u>Number</u>	<u>Wire</u>	<u>Material</u>	<u>Hole</u>	<u>O.D.</u>	<u>L</u>	<u>Q</u>
52-00007-000-0-00	8	Steatite	0.142"/0.162"	17/64"	31.4	1575
52-00007-100-0-00		Same as above in 6" tube.				
52-00008-000-0-00	11	Steatite	0.106"/0.162"	17/64"	26.0	1300
52-00009-000-0-00	13	Steatite	0.082"/0.102"	13/64"	47.9	2875
52-00010-100-0-00		Same as above in 6" tube.				
52-00011-100-0-00		Same as above in 6" tube.				
52-00014-100-0-00	18	Steatite	0.046"/0.066"	7/64"	0.004 lbs per tube	

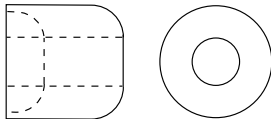

Heads

Thermocouple Heads

Introduction

Thermocouple heads provide the means for making connection between thermocouple and extension wire, and protect the connection against corrosion, abrasion and breakage caused by handling. Thermocouple heads are easy to install and are convenient for checking purposes. An outlet for conduct connection is provided with a selection of threaded outlet sizes for the protection tube.

General Purpose Heads

Available in aluminum or cast iron, these heads are superior in durability and convenience. A quick acting, tempered wire clamp holds the molded cover tightly against a gasket, making a positive seat. Aluminum head weighs 10 ounces; cast iron head weighs 27 ounces.

Weatherproof Head with Internal Threads

Weatherproof heads provide complete protection from weather in outdoor locations. In sheltered areas they provide greater protection in chemical and petroleum plants. The screw on cover, with close fitting threads, tightens against a gasket. The internal threads are protected from ambient atmosphere by the gasket seal. Double lugs, integral with the cast cover provide for removal by means of a screwdriver or wrench. Weighs 52 ounces.

Explosionproof Heads

HD11 is cast iron body, and copper free aluminum screw on cover for hazardous areas. Class I, groups C and D; class II, groups E, F, and G; class III. One outlet for element and two outlets for conduit connectors. Weighs 40 ounces.

HD16 is aluminum, single conduit connector head; class I, II groups A, B, C, D, E, F, G.

Plastic Weatherproof Head

The 1/4 NPT fitting will accept two, three or four 16 gauge wires. Weighs 3 ounces.

Miniature Connecting Head

The natural finish aluminum head is drilled to receive a 1/8 NPT fitting or protection tube through which the thermocouple wires are run to make a solder connection with the lead wire binding screw posts. The cover is attached to the head by means of two screws. Weighs two ounces.

Open Terminal Head

Generally for platinum thermocouples, this solid brass head is ideally suited for laboratory and many process applications. External terminal screws, with polarity encoded on heads, permit rapid change of lead wires for test purposes.

Open Ceramic Wafer Head

The open wafer head is designed for locations where protection is not required. The open head allows extension wires to be removed and replaced quickly and easily. Maximum temperature is 1000F°. Accepts 0.040", 0.062", 0.125", 0.188", and 0.250" diameter tubes. Weighs one ounce.

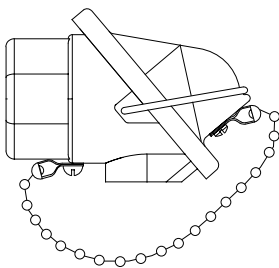

General Purpose
Code HD01, Cast Iron
Code HD03, Aluminum

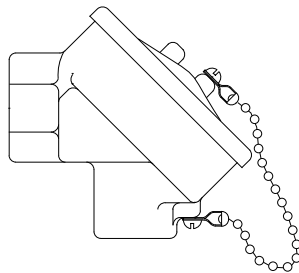

Weatherproof,
Code HD04, Cast Iron
Code HD12, Aluminum

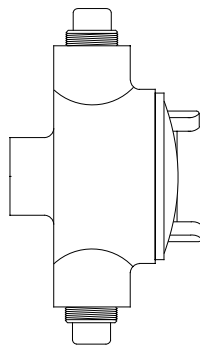

Explosion Proof
Cast Iron Body,
Aluminum Cover
Code HD11

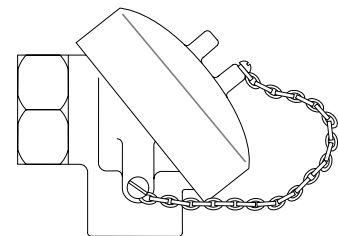

Explosion Proof
Class I, II; Groups
A, B, C, D, E, F, G
Code HD16

Heads

Ordering Information

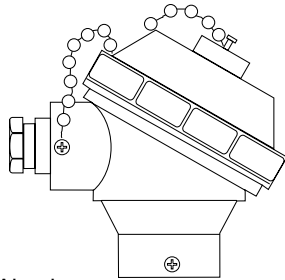

Aluminum ,
Transmitter Ready
Code HD17

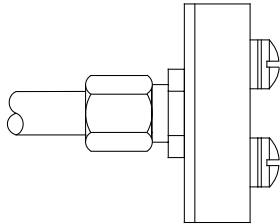

Ceramic Wafer
Code HD05

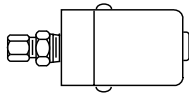

Miniature
Code HD06

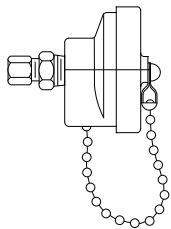

Plastic Weatherproof
Codes HD08, HD09

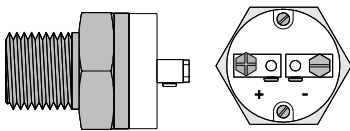

Open Terminal
Code HD14
Code HD15 (illustrated)

Model No. H D - **0** **0** - - **0 - 0 0**
Field No. 1 2 3 4 5 6 7 8 9 10 11 12 13 14 15

Compose model number from this list.

Fields 1, 2. BASE MODEL

HD - Head

Fields 3, 4. STYLE

- 01 - Cast iron general purpose (Obsolete use code "04")
- 03 - Aluminum general purpose (Obsolete use code "12")
- 04 - Cast iron, internal threads, weatherproof
- 05 - Open ceramic wafer
- 06 - Miniature connecting head
- 08 - Plastic weatherproof, 350°F maximum
- 09 - Plastic weatherproof, 800°F maximum
- 11 - Cast iron explosionproof (Fields 7 and 8 must be same NPT)
- 12 - Aluminum, internal threads, weatherproof
- 14 - Brass open head, without process mount threads
- 15 - Brass open head, with process mount threads
- 16 - Aluminum explosionproof (extended lead time)
- 17 - Aluminum, DIN size (Obsolete)

Field 5. TERMINAL BLOCK

- 0 - None
 - 1 - Single, 2 wire
 - 2 - Dual, 4 wire
- Applicable only codes 14, 15, 16, 17 in Fields 3,4**
- 3 - Single, 3 wire
 - 4 - Dual, 6 wire

Field 6. RESERVED

Field 7. TUBE NPT

- 0 - Not applicable.
- 1 - 1/8"
- 2 - 1/4"
- 4 - 1/2"
- 6 - 3/4"
- 8 - 1"

Field 8. CONDUIT NPT

- 4 - 1/2"
- 6 - 3/4"

Field 9. RESERVED

Fields 10, 11, 12. TUBE SIZE

- 000 - Not applicable – other than Ceramic Wafer style.
- 040 - Ceramic Wafer style only - 0.040" tube
- 062 - Ceramic Wafer style only - 0.0625" tube
- 125 - Ceramic Wafer style only - 0.125" tube
- 188 - Ceramic Wafer style only - 0.188" tube
- 250 - Ceramic Wafer style only - 0.250" tube

Fields 13, 14, 15. RESERVED

Filled cell = not compatible; blank cell = compatible

Fields 3, 4	Field 7						Field 8			
	0	1	2	4	6	8	0	2	4	6
01										
03										
04										
05										
06										
08										
09										
11										
12									Note	
14										
15										
16										
17										

Note: 3/4" conduit connector with 1/2" reducing bushing supplied.

Heads

Thermocouple Heads Table

HD01-00X40-000-0-00 (Obsolete)
HD01-10X40-000-0-00 (Obsolete)
HD01-20X40-000-0-00 (Obsolete)

HD03-00X40-000-0-00 (Obsolete)
HD03-10X40-000-0-00 (Obsolete)
HD03-20X40-000-0-00 (Obsolete)

HD04-00XX0-000-0-00
HD04-10XX0-000-0-00
HD04-20XX0-000-0-00

HD05-10000-XXX-0-00

HD06-10100-000-0-00
HD06-20100-000-0-00
HD08-20220-000-0-00
HD09-20220-000-0-00

HD11-00X40-000-0-00
HD11-10X40-000-0-00
HD11-20X40-000-0-00

HD12-00X40-000-0-00
HD12-10X40-000-0-00
HD12-20X40-000-0-00

HD14-10X00-000-0-00
HD14-20X00-000-0-00
HD14-30X00-000-0-00
HD14-40X00-000-0-00

HD15-10X00-000-0-00 (Obsolete)
HD15-20X00-000-0-00 (Obsolete)
HD15-30X00-000-0-00 (Obsolete)
HD15-40X00-000-0-00 (Obsolete)

HD16-10X60-000-0-00 (Obsolete)
HD16-20X60-000-0-00 (Obsolete)
HD16-40X60-000-0-00 (Obsolete)

HD17-00X60-000-0-00 (Obsolete)
HD17-10X60-000-0-00 (Obsolete)
HD17-20X60-000-0-00 (Obsolete)
HD17-30X60-000-0-00 (Obsolete)
HD17-40X60-000-0-00 (Obsolete)

Terminal Blocks

Terminal Blocks

Single



Brass terminal blocks mounted in molded porcelain to prevent shorts. Screws trap the lead wire between the corner of the block and the screw to make a good connection without the necessity of making a wire loop or sharp right angle bend. Weighs three ounces.

Duplex



Porcelain duplex terminal block provides connections for two sets of thermocouple wire and lead wire of 8 gauge or smaller. Brass terminal blocks minimize temperature gradient between connections. Polarity is indicated by raised characters on the block. Weighs 3 ounces.

A-12271-000-0-00 Single element terminal block (Obsolete)
A-12272-000-0-00 Dual element terminal block (Obsolete)

50-1863 Single element terminal block used on HD04, HD12, HD14 heads
50-1865 Dual element terminal block used on HD04, HD12, HD14 heads
50-1864 3 wire RTD or Thermowells terminal block used on HD04, HD12, HD14
50-1866 6 wire RTD or Thermowells terminal block used on HD04, HD12, HD14

Plugs and Jacks

Plugs and Jacks General Purpose

Introduction

Quick Disconnect

Quick disconnect plugs and jacks are molded, glass filled plastic with the attaching parts made of material to match a particular thermocouple type. Made to exacting specifications, these devices provide rapid connection/disconnection between thermocouple and lead wire with negligible contact resistance for transmission of the lowest millivoltages. Frequent make or break will not impair the accuracy of the mating parts. They are ideally suited for laboratory or industrial uses where the ambient temperature does not exceed 450°F. Minimum size: 33 AWG; maximum size: 14 AWG.

Ordering Information

Model No. H D - 0 0 0 0 - 0 0 0 - 0 - 0 0
Field No. 1 2 3 4 5 6 7 8 9 10 11 12 13 14 15

1-1/4" diameter
cutout

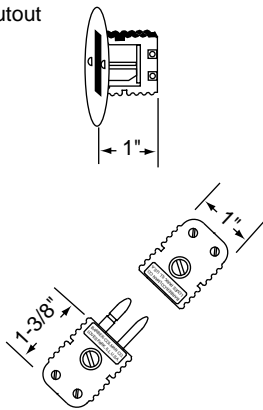

Fields 1, 2, 3, 4. BASE MODEL

- HD20 - Quick disconnect plug (solid machined pin)
- HD33 - Quick disconnect plug (hollow pin, Type J only)
- HD21 - Quick disconnect jack
- HD22 - Panel jack

Fields 5, 6, 7, 8. RESERVED

Field 9. THERMOCOUPLE TYPE

- C - Type C (red)
- E - Type E (purple)
- J - Type J (black)
- K - Type K (yellow)
- R - Type R or Type S (green)
- T - Type T (blue)
- U - Uncompensated (white)

Fields 10 through 15. RESERVED

Single Jack Panel Mounting Bracket. 1-1/4" hole cutout.

A-11903-000-0-00

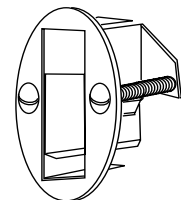

Plugs and Jacks

Plugs and Jacks High Temperature, and Three Pin

Introduction

Quick disconnect plugs and jacks are available in both two pin and three pin versions for thermocouples and RTDs.

High Temperature Two Pin

These high temperature jacks are compatible with all standard size industrial plugs, jacks and multiple jack panels. Negative pin and insert are larger for polarization. Rated to 800°F continuously, with short term rating to 1000°F – except thermocouple type U (uncompensated) is 400° maximum. The plug and jack bodies are glass filled silicone resin. The plug weighs one ounce; jack one-half ounce; and panel jack, one ounce.

Three Pin

Three pin connector used for three wire thermocouple or RTD. The third pin is copper for shield connection, except all pins are copper on Type U plug. Weight: 2 ounces.

Ordering Information

1-1/4" diameter cutout

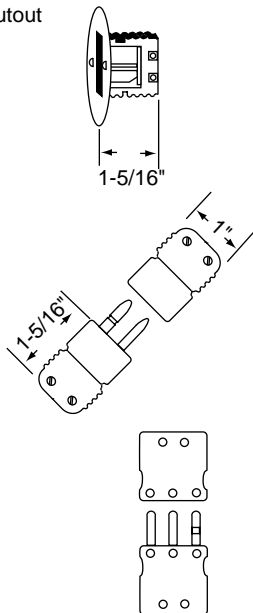

Model No. H D - **0 0 0 0** - **0 0 0 - 0 - 0 0**
Field No. 1 2 3 4 5 6 7 8 9 10 11 12 13 14 15

Fields 1, 2, 3, 4. BASE MODEL

Two Pin High Temperature

HD23 - Quick disconnect plug

HD24 - Quick disconnect jack

HD25 - Panel jack

Three Pin

HD29 - Quick disconnect plug

HD30 - Quick disconnect jack

Fields 5, 6, 7, 8. RESERVED

Field 9. THERMOCOUPLE TYPE

C - Type C (Two pin high temperature only)

E - Type E

J - Type J

K - Type K

R - Type R or Type S

T - Type T

U - Uncompensated

Fields 10 through 15. RESERVED

Plugs and Jacks

Plugs and Jacks Accessories

Connector Lock



To prevent accidental separation of plug and jack. Two can be used for additional protection. Material is nickel plated piano wire. Fits standard size plug or jack.

25-00170-100-0-00

Tube Adapters

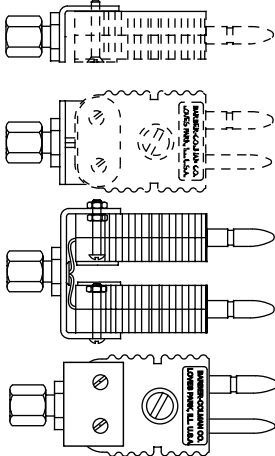

Attaches to either plug or jack with screws provided. Tube adapter makes rigid connection with tube – prevents twisting wires. Material is nickel plated steel. Each weighs one-half ounce.

A-10911-000-0-00	1/25" Tube	Single Plug or Jack
A-07389-000-0-00	1/16" Tube	Single Plug or Jack
A-07120-000-0-00	1/8" Tube	Single Plug or Jack
A-07121-000-0-00	3/16" Tube	Single Plug or Jack
A-07390-000-0-00	1/4" Tube	Single Plug or Jack
A-10872-000-0-00	1/16" Tube	Dual Plug or Jack
A-10485-000-0-00	1/8" Tube	Dual Plug or Jack
A-10486-000-0-00	3/16" Tube	Dual Plug or Jack
A-10873-000-0-00	1/4" Tube	Dual Plug or Jack

Single Plug Cable Clamp

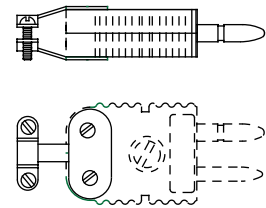

Attaches to either plug or jack with screws provided. Nickel plated steel. Weighs one-half ounce.

A-07124-000-0-00

Dual Extension Bracket

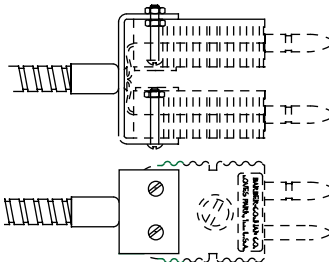

Weighs one-half ounce.

A-10380-000-0-00

Plugs and Jacks

Plugs and Jacks Miniature

Introduction

These plugs and jacks can be used where space is at a premium. Temperature not to exceed 300°F. Each item weighs one-half ounce.

Ordering Information

Model No. H D - 0 0 0 0 - 0 0 0 - 0 - 0 0
Field No. 1 2 3 4 5 6 7 8 9 10 11 12 13 14 15

Fields 3, 4. BASE MODEL

HD26 - Quick disconnect plug
HD27 - Quick disconnect jack
HD28 - Panel jack

Fields 5, 6, 7, 8. RESERVED

Field 9. THERMOCOUPLE TYPE

C - Type C
E - Type E
J - Type J
K - Type K
R - Type R or Type S
T - Type T
U - Uncompensated

Fields 10 through 15. RESERVED

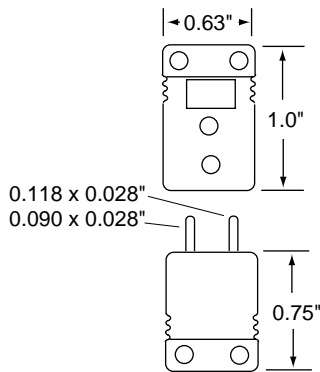

Miniature Jack Panel Adapter Clip
11-03661-000-0-00

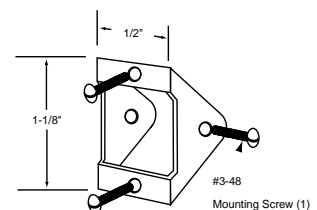

Jacks Panels

Multiple Jacks Panel

Introduction

The multiple jacks panel can be wired and installed from the front of the panel. Jack panels are available with up to 12 circuit connections. A self-contained fastening device is permanently attached for simplified mounting. Strong metal T nuts are drawn up against the back wall of the mounting surface and held in position by screws tightened from the front.

The jack panel matches ANSI thermocouple grade calibrations to maintain sensing accuracy. Alloy and circuit numbers are marked on the face of the panel. The corresponding circuit numbers and polarity identification are marked on the back.

The low mass of flange type spring-loaded inserts eliminates temperature gradients and spurious EMF. Correct polarity is achieved by having the negative inserts larger than the positive ones.

The jacks are molded of a high performance reinforced compound that will withstand ambient temperatures up to 300°F. They accept quick disconnect plugs. Each jack circuit weighs one ounce.

Mounting

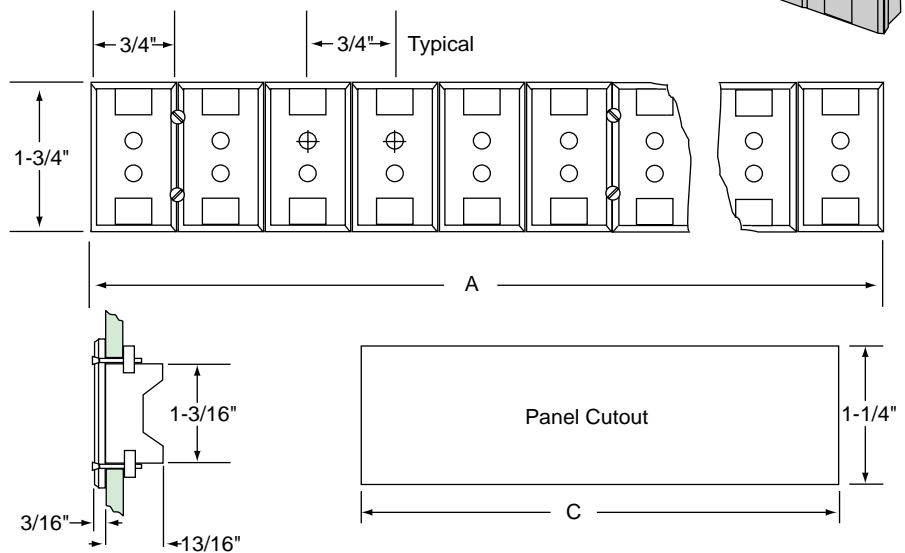
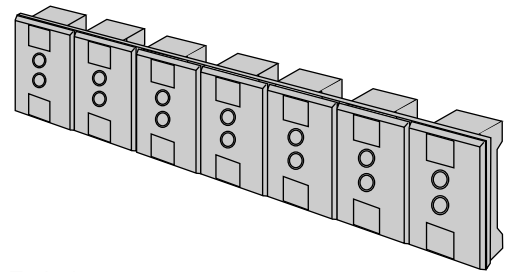

Dim	Number of Circuits										
	2	3	4	5	6	7	8	9	10	11	12
A	1-1/2	2-1/4	3	3-3/4	4-1/2	5-1/4	6	6-3/4	7-1/2	8-1/4	9
C	1-5/16	2-1/16	2-13/16	3-9/16	4-5/16	5-1/16	5-13/16	6-9/16	7-5/16	8-1/16	8-13/16

Note: Dimensions in inches.

Jacks Panels

Ordering Information

Model No. HD40-0000 - **000** - -
Field No. 1 2 3 4 5 6 7 8 9 10 11 12 13 14 15

Fields 1 through 4. BASE MODEL

HD40- Multiple Jacks Panel

Fields 5 through 8. RESERVED

Field 9. THERMOCOUPLE TYPE

- C - Type C
- E - Type E
- J - Type J
- K - Type K
- R - Type R or Type S
- T - Type T
- U - Uncompensated

Fields 10, 11, 12. RESERVED

Field 13. MOUNTING

- H - Horizontal
- V - Vertical

Fields 14, 15. NUMBER OF CIRCUITS

- 02 - Two
- 03 - Three
- 04 - Four
- 05 - Five
- 06 - Six
- 07 - Seven
- 08 - Eight
- 09 - Nine
- 10 - Ten
- 11 - Eleven
- 12 - Twelve

Jacks Panels

Five Jacks Panel

Introduction

This is a single unit, phenolic plastic, five jacks panel that can be mounted in a standard electrical conduit box (FS or FD). Panels can be connected to make a large panel with electrical conduit gang boxes. Contacts are of thermocouple calibration material and of standard size to accept the quick disconnect plug. On special order, the panel can be assembled in any combination of outlet calibrations. Etched aluminum discs on the front panel identify the thermocouple calibration. Weight: four ounces.

Mounting

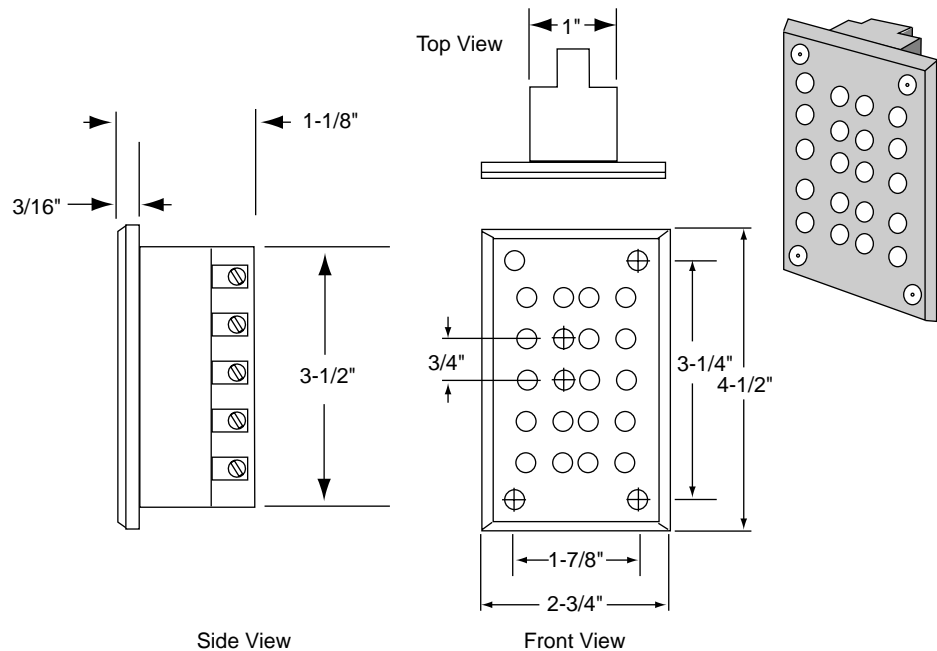

Ordering Information

Model No. HD41-0000□-000-0-05
Field No. 1 2 3 4 5 6 7 8 9 10 11 12 13 14 15

Fields 1 through 4. BASE MODEL
HD41- Five Jacks Panel

Fields 5 through 8. RESERVED

Field 9. THERMOCOUPLE TYPE

- J - Type J
- K - Type K
- T - Type T

Fields 10 through 15. RESERVED

Protection Tubes

Protection Tubes

Introduction

Selection Information

A thermocouple should have as little protection as possible consistent with the length of service consideration. Sensitivity will be reduced and slower response to temperature changes results from very heavy tubes.

To insure longer life with accuracy, thermocouples must be adequately protected. Corrosion, contamination and abrasion all shorten the life of thermocouples. Protection tubes are capable of withstanding these actions.

For continuous duty, the temperatures shown are the maximum recommended. For intermittent duty, tubes may be worked at slightly higher temperatures than shown, but total length of life may be less.

Thermocouple protection tubes are available in a wide range of types and sizes. The tubes listed here are those which have been in greater demand and many of these are stocked for fast delivery. Other tubes for special purposes are available.

Closed end metal tubes are spun and welded closed. Ceramic and cast iron tubes are cast with a closed end.

Specifications and Applications

The following comments, temperature ratings, and application information are offered as a general guide only. This information is not to imply a guarantee of adequate or successful use of any of the listed materials in any specific application. Numerous variables such as impurities, concentrations, vibration, shock, temperature cycling, abrasion, etc. greatly influence the satisfactory life experienced from a protection tube material.

The length of service considered satisfactory in one application may be unsatisfactory in another. Testing of selected materials should be performed in the application for final determination of a suitable material.

In the following table, the "code" column shows the identifiers that appear in Fields 5, 6 of the thermocouple part number.

Code	Typical Applications	Description	Composition or Form	Maximum Temperature	General Comments
18, 19, 65, 66, 67	Food preparation; petroleum; chemical processes: mixed acids, lactic acid, dyeing tanks	304 stainless steel	Uncontrolled amounts of nickel, chromium, carbon, manganese, silicon; traces of phosphorous & sulfur, balance iron	Oxidizing 1600°F; non-oxidizing 2300°F	Good resistance to corrosion. For wet process applications such as steam, oil, and many chemical solutions.
44, 68, 69, 70	Petroleum industry, chemical process industries	316 stainless steel	12% nickel, 17% chromium, 2.5% molybdenum, 2% manganese max., 1% silicon max., .08% carbon max., traces of phosphorous and sulfur, balance iron	Oxydizing 1600°F	Good resistance to corrosion. Resists pitting corrosion. More resistant to acids than 304 SS.

Protection Tubes

Specifications and Applications (continued)

Code	Typical Applications	Description	Composition or Form	Maximum Temperature	General Comments
11, 12, 13	High temperature hardening, nitriding, salt baths, vitreous enameling, non-ferrous metals (tin, lead, zinc or babbitt metal), smelting, low temperature blast furnaces	446 stainless steel	27% chromium, 0.25% nitrogen max., 0.20% carbon max. 1.00% silicon max. traces of phosphorous & sulfur, balance iron	Oxidizing 2000°F, non-oxidizing 2300°F	Good resistance to corrosion at high temperatures. Impervious to sulfurous atmospheres, salt bath or low temperature molten metals.
14	Potassium Cyanide salt baths 2000°F; caustic and brines; high temperature chemical applications 1200°F	Pure nickel	Drawn or drilled 99.5% nickel	<u>Maximum Temperature:</u> 2200°F oxidizing, 1000°F reducing, 2400°F neutral <u>General Comments:</u> For high temperature applications. Will withstand many chemical actions but must not be placed in the presence of sulphur. Frequently placed in caustic and molten salt baths. Drilled tube recommended for hydrogen atmospheres.	
16, 17, 72, 73	High temperature heat treating, carburizing, nitriding, salt baths, blast furnace operations, gas generators, ceramic kilns	Inconel 601	61% nickel, 23% chromium, 14% iron, 1.35% aluminum	Oxidizing 2300°F	Excellent resistance to corrosion and oxidation at high temperature. Good mechanical strength. More resistant to sulfur than Inconel 600. Hydrogen causes embrittlement.
06, 07, 08	Tinning, molten non-ferrous metals (babbitt, magnesium, tin, etc.), water lines, petroleum applications	SAE 1020 or SAE 1018 steel (black steel)	0.17% carbon, 0.75% manganese, 0.035% phosphorous max., 0.045% sulfur max., balance iron	Oxidizing 1000°F, non-oxidizing 2000°F	Economical for low temperature applications. Scales easily at higher temperature. For non-corrosive atmospheres
02, 03, 04, 05	Annealing, drawing, tempering, glass lens, power plant preheaters, food baking ovens, asphalt mixers	Low carbon black steel	Uncontrolled amounts of carbon, manganese, silicon and copper, traces of phosphorous and sulfur, balance iron	<u>Maximum Temperature:</u> 1250°F <u>General Comments:</u> For non-corrosive atmospheres and in low temperature molten metals. Balck steel is a replacement for YOLOY and wrought iron. YOLOY is a trade name of Youngstown Steel and Tube.	
09	Chemical industry: molten aluminum, die cast metals	Cast iron	Cast iron	<u>Maximum Temperature:</u> Oxidizing 1300°F, non-oxidizing 2000°F <u>General Comments:</u> To 1600°F in reducing atmospheres. Will withstand sulfuric acid and caustic solutions. Process coated tubes are available for extra long life. Cast iron tubes should be painted daily with whiting when measuring aluminum or die cast metal temperatures.	

Protection Tubes

Specifications and Applications (continued)

Code	Typical Applications	Description	Composition or Form	Maximum Temperature	General Comments
28	High temperature heat treating: molten copper base alloys to 2100°F, blast furnace and stack gases to 2400°F, sulfur burners to 2000°F, cement kilns to 2200°F, chemical process reactors to 2500°F	Metal-ceramic tubes	(Slip cast composite of chromium & aluminum oxide) 77% chromium, 23% aluminum oxide	2500°F	Superior oxidization resistance to 2500°F. Thermal conductivity equal to that of stainless steel. Good resistance to most molten metals to 2100°F. Not usable in molten aluminum. With noble metal element, a ceramic primary tube is required.
23, 24, 25	Ceramics industry: bright annealing, forging furnaces, glass making, high speed salt baths	Mullite	63.5% Al ₂ O ₃ , 34.2% SiO ₂ , 6% Fe ₂ O ₃ , 6% TiO ₂ , 1% CaO, 4% MgO, 6% Na ₂ O	<u>Maximum Temperature:</u> 2900°F <u>General Comments</u>	Impervious to gases at high temperature. Possesses good thermal shock but poor mechanical shock. Often necessary to provide secondary tube protection. Should be mounted vertically. Usable in barium chloride salt baths to 2350°F
29, 30, 31	Induction melting up to 3200°F applications for metal and ceramic industry requiring extreme temperatures	Alumina	99.8% Al ₂ O ₃ Trace SiO ₂ Trace MgO Trace Na ₂ O	3400°F	Fair resistance to thermal and mechanical shock. For very high temperature processes. Impervious to gases up to 3200°F
21, 22	Brick and ceramic kilns, steel soaking pits, applications requiring resistance to cutting action of flames and gases	Ceramic tubes silicon carbide	90% silicon carbide, 9% silicon dioxide, balance aluminum oxide and ferric oxide	3000°F	For molten non-ferrous metals. Also is a secondary protection tube for resistance to thermal shock.
41, 42	Foundries: aluminum and other non-ferrous metals	Ceramic clad tubes	Composite fiberglass fabric, silicon carbide tip and ceramic coating	<u>Maximum Temperature:</u> 1700°F <u>General Comments</u>	Not wetted by molten aluminum and other non-ferrous metals. No contamination. Resists thermal and mechanical shock. Brittle after heating; handle carefully. Code 42 is spring loaded
46	Molten tin, zinc, lead and aluminum	Silicon carbide over black steel	90% silicon carbide, 9% silicon dioxide, balance aluminum oxide and ferric oxide.	1600°F	For molten non-ferrous metals

Protection Tubes

Ordering Information

Model No. 0 0 □ □ - □ □ □ □ □ - □ 0 0 - □ - □ □
 Field No. 1 2 3 4 5 6 7 8 9 10 11 12 13 14 15

Notes

1. Consult factory for longer lengths of ceramic cast metal or gun drilled tubes.
2. Open ended tubes will be one inch shorter than specified length.

Fields 1, 2. RESERVED

Fields 3 through 9. BASE MODEL

 Complete Fields 14, 15 to determine length.

W = weight, in ounces, per 6"; L = minimum length available.

W L

42-02100 - Black steel, 1/4" NPS		
42-03121 - Black steel, 1/2" NPS	6.25	12"
42-04142 - Black steel, 3/4" NPS		
42-05170 - Black steel, 1" NPS	11	12"
42-06342 - Welded steel, 1/8" NPS	3.5	12"
42-07300 - Welded steel, 1/4" NPS	3	12"
42-08321 - Welded steel, 1" NPS	17	12"
42-09401 - Cast iron	38	12"
43-11333 - 446 stainless steel, 3/4" NPS	6	12"
43-12300 - 446 stainless steel, 1/2" NPS	6	12"
43-13307 - 446 stainless steel, 1" NPS	12.5	12"
43-14407 - Pure nickel, 1/2" NPS		
43-16500 - Inconel, 1/2" NPS	7	12"
43-17507 - Inconel, 3/4" NPS	9	12"
43-18607 - 304 stainless steel, 1/4" NPS	3	12"
43-19628 - 304 stainless steel, 1/2" NPS	6.5	12"
43-26522 - Incoloy 800, 1/2" NPS		
43-27530 - Incoloy 800, 3/4" NPS		
43-44650 - 316 stainless steel, 1/2" NPS	6.5	12"
43-47651 - 316 stainless steel, 3/4" NPS		
44-21200 - Silicon Carbide, 1-3/4" o.d.	13.5	12"
44-22207 - Silicon Carbide with collar		
44-23403 - High temp. porcelain, 3/8" o.d.	0.5	6"
44-24417 - High temp. porcelain, 11/16" o.d.	2	6"
44-25438 - High temp. porcelain, 1" o.d.	2	6"
44-28472 - Metal ceramic, 7/8" o.d.	4	12"
44-29100 - Aluminum oxide, 3/8" o.d.	0.5	6"
44-30107 - Aluminum oxide, 11/16" o.d.	2.25	6"
44-31114 - Aluminum oxide, 1" o.d.	4.5	6"
44-34121 - Aluminum oxide, 7 mm		
44-41016 - Ceramic clad	8	12"
0A-10555 - Ceramic clad with spring.	8	18"
0A-11884 - Reinforced silicon carbide.	19.5	18"
0A-10775 - 304 stainless steel, 0.160" x 0.185"		
0A-11228 - 304 stainless steel, 0.194" x 0.250"		

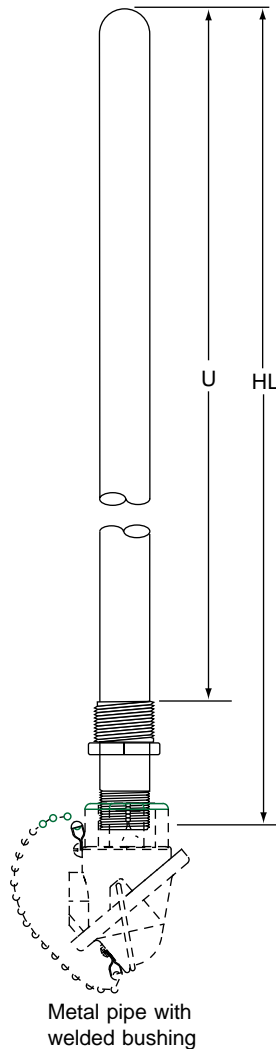

Protection Tubes

Ordering Information (continued)

Field 10. END CONFIGURATION

- 0 - Closed, no threads (standard for ceramic tubes)
- 1 - Closed, threaded (standard for metal tubes)
- 2 - Open, threaded (see note 2, preceding page)

Fields 11, 12. RESERVED

Field 13. MOUNTING FITTINGS

Either Metal Pipe or Ceramic Tube

- 0 - None (Required when base model, Fields 3 through 9, is 42-01408, 42-09401, 44-41016, or A-10555)
- 2 - Adjustable flange

Metal Pipe (Specify "U" dimension on order, max. "U" dim. = hot length minus 2")

- 8 - Welded bushing, black steel, one size larger than pipe (standard)
- A - 1/2" welded bushing, black steel
- B - 3/4" welded bushing, black steel
- C - 1" welded bushing, black steel
- D - 1-1/2" welded bushing, black steel
- M - 1-1/4" welded bushing, black steel
- E - 1/2" welded bushing, 316 stainless steel
- F - 3/4" welded bushing, 316 stainless steel
- G - 1" welded bushing, 316 stainless steel
- N - 1-1/4" welded bushing, 316 stainless steel
- H - 1-1/2" welded bushing, 316 stainless steel

Fittings for Metal Pipe Protection Tubes

Pipe Size	Available Fitting Codes
1/8" NPT	0, 2, 8, A, B, C, E, F, & G
1/4" NPT	0, 2, 8, A, B, C, E, F, & G
1/2" NPT	0, 2, 8, B, C, D, F, G, H, M & N
3/4" NPT	0, 2, 8, D, G, H, M & N
1" NPT	0, 2, 8, D, H, M & N

Ceramic Tube

- 1 - 4" Black steel sleeve
- 3 - 4" Stainless steel sleeve
- 4 - 4" Stainless steel sleeve and flange
- 5 - 4" Black steel sleeve and flange
- 6 - Single ended bushing
- Y - Reducing sleeve adapter (Thermocouple part number Fields 5, 6 code 21, silicon carbide tube only)
- 7 - Double ended bushing
- P - Double ended bushing, 1/2" x 3/4" (Base models, Fields 3 through 9, 44-24417 and 44-30107 only)
- R - Black steel sleeve longer than 4". Specify length on order.*
- T - Stainless steel sleeve longer than 4". Specify length on order.*
- V - Stainless steel sleeve and flange longer than 4". Specify length on order.*
- W - Black steel sleeve and flange longer than 4". Specify length on order.*

Fields 14, 15. HOT LENGTH (DIMENSION "HL")

-  Complete these Fields to determine length for Fields 6 through 9
- HL - HL dimension in whole inches

Thinwall Tube Protection Tubes

Thinwall Tube Protection Tubes

Ordering Information

Thinwall Protection tubes have a unique model numbering system.

Model No. A- - - -

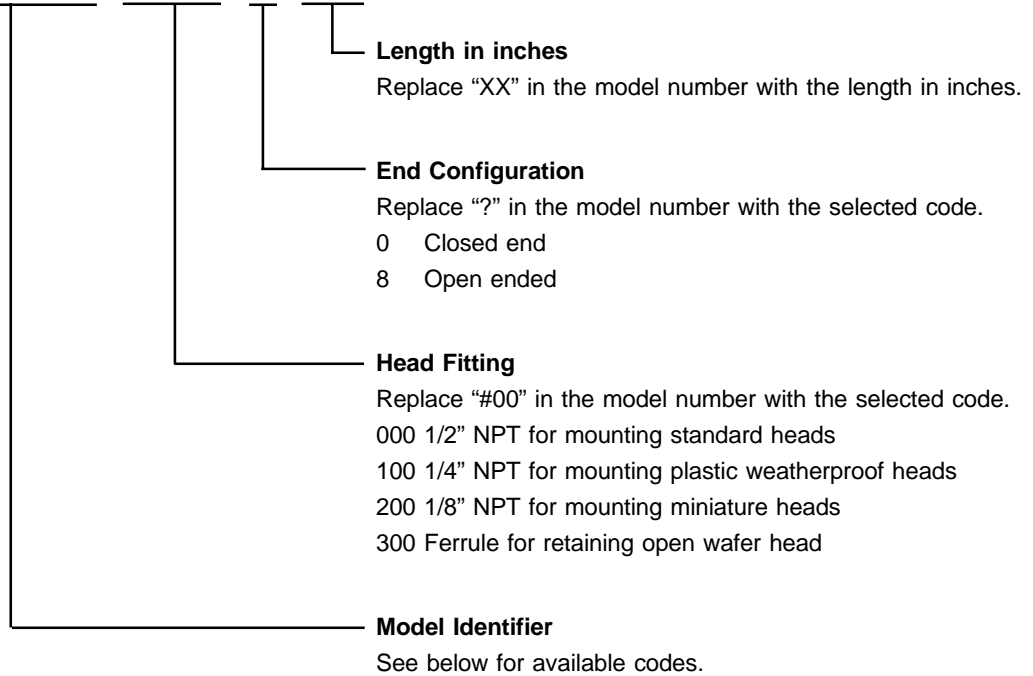

Wire & Accessories

Model Number

A-10775-#00-?-XX	.188" OD, (3/16") 304 Stainless Steel
A-11228-#00-?-XX	.250" OD, (1/4") 304 Stainless Steel
A-10782-#00-?-XX	.375" OD, (3/8") 304 Stainless Steel
A-10789-#00-?-XX	.188" OD, (3/16") 316 Stainless Steel
A-11235-#00-?-XX	.250" OD, (1/4") 316 Stainless Steel
A-10797-#00-?-XX	.375" OD, (3/8") 316 Stainless Steel
A-11242-#00-?-XX	.250" OD, (1/4") Inconel
A-11151-#00-?-XX	.375" OD, (3/8") Inconel

# Code	Head mounting
000	1/2" NPT for mounting standard heads
100	1/4" NPT for mounting plastic weatherproof head
200	1/8" NPT for mounting miniature heads
300	Ferrule for retaining open wafer head

? Code	End Configuration
0	Closed end
8	Open ended

XX Code Replace "XX" in the model number with the length in inches.

Bushings

Protection Tube Bushings

Ordering Information

Adapter Bushing

Threaded inside and outside to adapt the metal protection tube to the thermocouple head

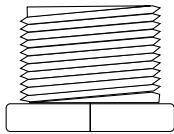

Steel Bushings		I.D.	O.D.	Ounces
PF10- C0102-000-0-00	1/8" NPT	1/4" NPT	1.0	
PF10- C0104-000-0-00	1/8" NPT	1/2" NPT	1.5	
PF10- C0106-000-0-00	1/8" NPT	3/4" NPT	3.0	
PF10- C0108-000-0-00	1/8" NPT	1" NPT	5.5	
PF10- C0204-000-0-00	1/4" NPT	1/2" NPT	1.0	
PF10- C0206-000-0-00	1/4" NPT	3/4" NPT	3.0	
PF10- C0208-000-0-00	1/4" NPT	1" NPT	1.5	
PF10- C0406-000-0-00	1/2" NPT	3/4" NPT	1.5	
PF10- C0408-000-0-00	1/2" NPT	1" NPT	4.0	
PF10- C0410-000-0-00	1/2" NPT	1-1/4" NPT	3.0	
PF10- C0412-000-0-00	1/2" NPT	1-1/2" NPT	6.0	
PF10- C0608-000-0-00	3/4" NPT	1" NPT	3.0	
PF10- C0612-000-0-00	3/4" NPT	1-1/2" NPT	8.0	

Stainless Steel Bushings		I.D.	O.D.	Ounces
PF10- F0102-000-0-00	1/8" NPT	1/4" NPT	1.5	
PF10- F0104-000-0-00	1/8" NPT	1/2" NPT	2.0	
PF10- F0106-000-0-00	1/8" NPT	3/4" NPT	3.5	
PF10- F0108-000-0-00	1/8" NPT	1" NPT	6.0	
PF10- F0204-000-0-00	1/4" NPT	1/2" NPT	1.5	
PF10- F0206-000-0-00	1/4" NPT	3/4" NPT	3.0	
PF10- F0208-000-0-00	1/4" NPT	1" NPT	2.0	
PF10- F0406-000-0-00	1/2" NPT	3/4" NPT	1.25	
PF10- F0408-000-0-00	1/2" NPT	1" NPT	5.5	
PF10- F0410-000-0-00	1/2" NPT	1-1/4" NPT	3.5	
PF10- F0412-000-0-00	1/2" NPT	1-1/2" NPT	6.5	
PF10- F0608-000-0-00	3/4" NPT	1" NPT	3.5	
PF10- F0612-000-0-00	3/4" NPT	1-1/2" NPT	8.5	

Process Mounting Bushing

Single ended steel bushing with outside tapered threads, and smooth bore for welding or cementing on protection tube. Stainless steel bushing for tubing, or MgO sheath.

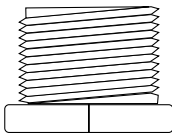

Zinc Plated Steel Bushings		I.D.	O.D.	Ounces
PF30- M0400-500-0-00	0.500"	1/2" NPT	2	
PF30- M0600-750-0-00	0.750"	3/4" NPT	2	
PF30- M0800-A09-0-00	1.093"	1" NPT	2	
304 Stainless Steel Bushings		I.D.	O.D.	Ounces
PF30- E0100-062-0-00	0.062"	1/8" NPT	2	
PF30- E0100-125-0-00	0.125"	1/8" NPT	2	
PF30- E0100-191-0-00	0.191"	1/8" NPT	2	
PF30- E0100-254-0-00	0.254"	1/8" NPT	2	

Bushings

Ordering Information (continued)

Double Ended Bushing

Silver soldered to thin wall tubing. Used for process mounting and attaching cold end termination.

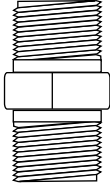

Model No. P F 3 5 - **-** **- 0 - 0 0**

Field No. 1 2 3 4 5 6 7 8 9 10 11 12 13 14 15

Fields 1, 2, 3, 4. BASE MODEL

PF35 - Double ended bushing

Fields 5 through 9. SIZE

F0202 - 1/4" NPT each end, 1-1/2" long

G0404 - 1/2" NPT each end, 1-3/4" long

E0606 - 3/4" NPT each end, 1-27/32" long

D0808 - 1" NPT each end, 2-7/32" long

Fields 10, 11, 12. TUBE OUTSIDE DIAMETER

040 - 0.040"

062 - 0.062"

125 - 0.125"

188 - 0.188"

250 - 0.250"

Fields 13, 14, 15. RESERVED

Compression Fittings

Protection Tube Compression Fittings

Introduction

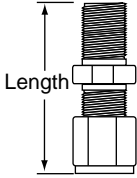

Compression fittings are placed on protection tubes or MgO sheathed wire. They cannot be moved after installation unless ferrule is Teflon.

Ordering Information

		Tube O.D.	NPT	Length	Ounces
316 Stainless Steel with Stainless Steel Ferrule					
PF70- F0100-040-0-00		1/25"	1/8"	1-1/32"	1/2
PF70- F0100-062-0-00		1/16"	1/8"	1-1/32"	1/2
PF70- F0100-125-0-00		1/8"	1/8"	1-3/16"	1
PF70- F0100-188-0-00		3/16"	1/8"	1-7/32"	1
PF70- F0100-250-0-00		1/4"	1/8"	1-9/32"	1
PF70- F0200-125-0-00		1/8"	1/4"	1-3/44"	1
PF70- F0200-188-0-00		3/16"	1/4"	1-3/4"	1
PF70- F0200-250-0-00		1/4"	1/4"	1-15/32"	1
PF70- F0400-375-0-00		3/8"	1/2"	1-13/16"	1
Nickel Plated Brass with Brass Ferrule					
PF70- K0100-040-0-00		1/25"	1/8"	1-1/16"	1/2
PF70- K0100-062-0-00		1/16"	1/8"	1"	1/2
PF70- K0100-125-0-00		1/8"	1/8"	1-1/16"	1/2
PF70- K0100-188-0-00		3/16"	1/8"	1-1/8"	1/2
PF70- K0100-250-0-00		1/4"	1/8"	1-1/8"	1/2
PF70- K0200-125-0-00		1/8"	1/4"	1-1/4"	1/2
PF70- K0200-188-0-00		3/16"	1/4"	1-1/4"	1
PF70- K0200-250-0-00		1/4"	1/4"	1-1/4"	1
PF70- K0400-250-0-00		1/4"	1/2"	1-1/2"	2
PF70- K0400-375-0-00		3/8"	1/2"	1-13/16"	2
316 Stainless Steel with Teflon Ferrule					
PF71- F0100-062-0-00		1/16"	1/8"	1-1/32"	1/2
PF71- F0100-188-0-00		3/16"	1/8"	1-7/32"	1
Nickel Plated Brass with Teflon Ferrule					
PF71- K0100-125-0-00		1/8"	1/8"	1-1/16"	1
PF71- K0100-188-0-00		3/16"	1/8"	1-1/8"	1
Teflon Fittings					
PF71 - L0100-250-0-00		1/4"	1/8"	1-1/2"	1/2

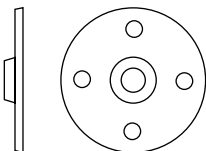

Compression Fitting Flange

1/4" NPT bore for any compression fitting with 1/4" NPT mounting threads. Flange is 2-13/16" diameter with four 1/4" diameter bolt holes on 1-7/8" diameter circle. Weight is 8 ounces.

PF45-A0000-002-0-00

Mounting Accessories

Protection Tube Mounting Accessories

Ordering Information

Adjustable Flange

Made of cast iron finished in black enamel. Provided with two set screws for clamping on the metal protecting tube or metal sleeve of a ceramic tube.

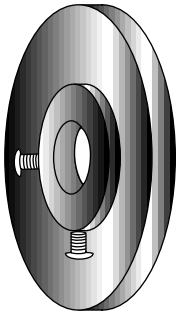

	<u>O.D. Tube</u>	<u>NPT</u>	<u>Bore</u>	<u>Flange</u>	<u>Ounces</u>
PF40-B0000 -001-0-00	0.405"	1/8"	27/64"	2-3/4"	5
PF40-B0000 -002-0-00	0.540"	1/4"	9/16"	3-1/4"	8
PF40-B0000 -003-0-00	0.675"	3/8"	11/16"	3-1/4"	7
PF40-B0000 -004-0-00	0.840"	1/2"	55/64"	3-5/8"	8
PF40-B0000 -006-0-00	1.050"	3/4"	1-5/64"	3-5/8"	9
PF40-B0000 -008-0-00	1.250"	1"	1-11/32"	4-1/2"	21
PF40-B0000 -010-0-00	1.660"	1-1/4"	1-3/4"	4-1/2"	22
PF40-B0000 -012-0-00	1.900"	1-1/2"	1-59/64"	4-1/2"	24

Reducing Sleeve Adapter

Provides a weatherproof and secure means of mounting a secondary protecting tube for silicon carbide noble metal thermocouple assemblies. Weighs 8 ounces. Inside diameter of 1-7/8", pipe thread size 3/4" NPT. For use with tube diameter of 1-3/4".

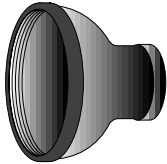

PF11-A0200-A75-0-00

Holder for Flanged Silicon Carbide Protection Tube

Flange is designed to mount on and hold a silicon carbide protection tube with collar protection tube code 22. Weight is 2 pounds, 5 ounces.



A-11212

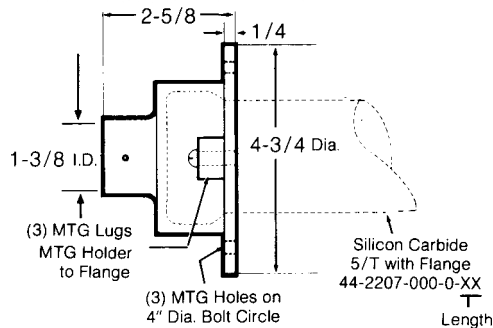

Potting Adapters

MgO Thermocouple Accessories Potting Adapters

Note: The following adapters are for single element thermocouples unless otherwise noted. Each adapter weighs 1/2 ounce maximum.



Transition between Thermocouple and Flexible Armor Cable

11-03446-000-0-00 0.063" outside diameter
11-03491-000-0-00 0.125" outside diameter
11-03447-000-0-00 0.188" outside diameter
11-03448-000-0-00 0.250" outside diameter



Transition between Thermocouple and Lead Wire

11-03445-000-0-00 0.040" outside diameter
11-03426-000-0-00 0.063" outside diameter
11-03427-000-0-00 0.125" outside diameter
11-03463-000-0-00 0.250" outside diameter
11-03461-000-0-00 0.063" outside diameter, dual element
11-03462-000-0-00 0.188" outside diameter, dual element