

# *Thermowells and Assemblies*



Thermowells

# Thermowells and Assemblies

## Introduction

Thermowells provide protection for thermocouples in pressure vessels and pipelines. A thermowell permits checking and replacing the thermocouple without draining the vessel or pipeline.

## Material

**The Longevity Factor.** In general, the thermowell material chosen for the installation is governed by the corrosion conditions of the well environment. Materials for various services are given in the corrosion table. The high mirror polish given to all stainless and monel wells provides maximum corrosion resistance.

Occasionally the material consideration is one of strength rather than corrosion. For example, a stainless steel well may be required for high pressure water service where otherwise a brass well would be satisfactory from a corrosion standpoint. Consult the pressure-temperature ratings given for each well type.

The standard materials listed for each well series will cover most requirements. A stock of material is carried at all times to insure fast delivery of wells of standard material.

## Connection

**The Installation Factor.** Threaded wells are made in readily welded or brazed materials. This is important for installations requiring seal welding or brazing. The pipe thread provides the mechanical strength; the weld merely seals.

## Insertion Length

**The Accuracy Factor.** The distance from the end of the well to the underside of the thread, or other connection means (designated as "U"), is the insertion length. For best accuracy, this length should be long enough to permit the entire temperature sensitive part of the thermometer bulb to project into the temperature medium being measured. A properly installed thermometer bulb will project into liquid an amount equal to its sensitive length plus at least one inch. In air or gas, the bulb should be immersed its sensitive length plus at least three inches.

Thermocouples and thermistors have short sensitive lengths and therefore can use the smallest insertion lengths.

Bi-metal thermometers, resistance temperature detectors, and liquid-in-glass thermometers have bulbs with sensitive portions between one and two inches long. Therefore, the minimum standard insertion length of 2-1/2" must be entirely immersed in liquid for proper accuracy.

Filled system thermometer bulbs may have sensitive portions from one to several inches in length. Determine the sensitive length of the bulb before choosing an insertion length.

Above all, be sure the dead length (that required to pass through walls, pipe fittings, etc.) is taken into account when choosing the necessary well insertion length.

## Bore Size

**The Interchangeability Factor.** Almost any installation uses several types of temperature measuring instruments. The selection of a standard bore diameter can produce extreme flexibility within the plant. The same well can accommodate a thermocouple, resistance temperature detector, bi-metal thermometer, or test thermometer. The bore size of wells shown in this document cover the most commonly used temperature sensing elements as follows:

### **0.260" Diameter Bore**

- Bi-metal thermometers (1-1/4" stem)
- RTD and MgO thermocouples
- Liquid-in-glass test thermometers (non-armored)
- Other elements having 0.252" maximum diameter

### **0.385" Diameter Bore**

- Bi-metal thermometers (3/8" stem)
- Thermocouples (14 and 20 gauge)
- Liquid-in-glass thermometers (armored)
- Other elements having 0.377" maximum diameter

# *Thermowells and Assemblies*

## Introduction (continued)

- Shank – Tapered or Straight**    **The Velocity Rating Factor.** Tapered shank wells provide greater stiffness for the same sensitivity. The higher strength to weight ratio gives these wells higher natural frequency than for equivalent length straight shank wells, thus permitting operation at higher fluid velocity. See “Velocity Rating of Wells.”
- With Lag and No Lag**            Thermowells are offered either with or without lag. Lag styles permit clearance for insulation or other material surrounding the pipe or process vessel.

# Thermowells and Assemblies

## Ordering and Pricing Instructions

The following are available:

### Thermowell Assemblies (element installed in thermowell)

- MgO insulated element
- Ceramic insulated element
- RTD element

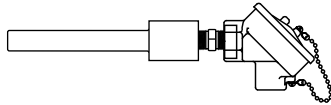

When ordering a complete assembly, you must specify dimensions for the thermowell (Fields 5 through 12) and the head to well connector (Field 13) before you can price the element. Therefore, begin the procedure with Field 5 from page 5-10; then complete Fields 13 through 15 from page 5-12. Finally, complete Fields 1 through 4 for the required element: MgO insulated, page 5-6; ceramic insulated, page 5-8; or RTD, page 5-9.

3
1
2

↓
↓
↓

3
1
2

□ □ □ □
□ □ □ □ □ □ □ □
□ □ □ □ □ □ □ □
□ □ □ □

Field No.
1 2 3 4
5 6 7 8 9
10 11 12
13
14
15

### Replacement Element, with or without Head and Connection

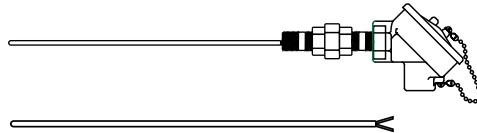

When ordering a replacement element, you need dimensions from the existing assembly into which the element will be placed. The illustration below shows components of a typical thermowell assembly, and the fields in the model number that specify each of these components. Note that dimensions "A" and "N" pertain to the sensor element. Various styles of thermowells (for dimension "A") are illustrated on pages 5-14, 5-15. Connections (for dimension "N") are illustrated on page 5-12.

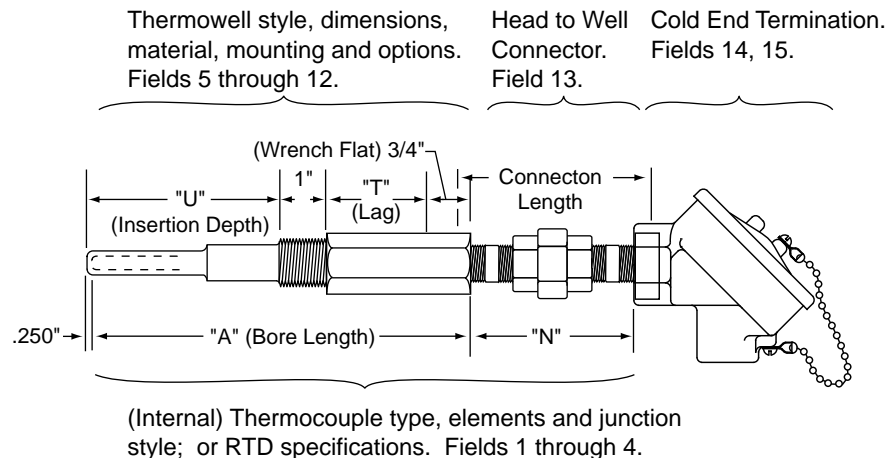

# Thermowells and Assemblies

## Ordering and Pricing Instructions (continued)

First, determine the length of the element. If you know the dimensions of the existing thermowell, you can calculate element length by adding A + N. A and N formulas are:

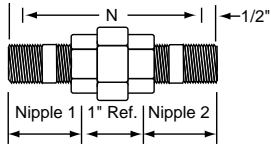
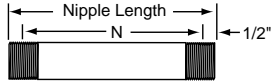

Field 13, Code	"N" =
0	0"
A, C, E, J	3"
B, D	Nipple length - 1"
F, K	Combined length of Nipple 1 and Nipple 2
L	Not applicable
G, H	Not applicable

For thermowell styles A, B, E, M, N, P, R (Field 5)  $A = U + T + 1-1/2"$   
 For thermowell styles D, Q, F, S, T, U (Field 5)  $A = U + T + 2"$

For connector codes A, C, E, J (Field 13)  $N = 3"$   
 For connector codes B, D (Field 13)  $N = \text{nipple length less } 1"$   
 For connector codes F, K (Field 13)  $N = \text{combined length of nipples 1 and 2}$   
 For connector codes O and L (Field 13)  $N \text{ is not applicable}$   
 For connector codes G and H (Field 13)  $N \text{ is not applicable}$

After determining the required length of the element, complete Fields 1 through 4: MgO insulated element, page 5-6; ceramic insulated element, page 5-8; or RTD element, page 5-9. Enter zeros in Fields 5 through 12; then complete Fields 13 through 15 from page 5-12. If you are not ordering a connection and head, enter zeros in these fields.

**NOTE:** Even if you are not ordering a connection and head with your element, you must identify (on your order, by codes from Fields 13 through 15) the connection and head on your present assembly. This information is required by the factory in order to provide the proper lead length.

Model No.     - 0 0 0 0 - 0 0 0 -  -

Field No. 1 2 3 4 5 6 7 8 9 10 11 12 13 14 15

### Thermowell only

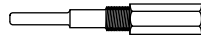

If you are ordering a thermowell only, complete the following part number from page 5-10.

Model No. T H 0 0 -      -    - 0 - 0 0

Thermowells

# Thermowells and Assemblies

## MgO Insulated Thermocouple Element

### Ordering Information

Model No.     -      -    -    -     
 Field No. 1 2 3 4 5 6 7 8 9 10 11 12 13 14 15

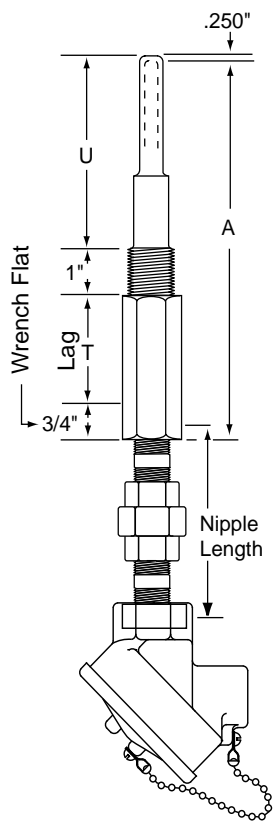

Representative of threaded styles A, M, B, N and P (Field 5) with union connector:

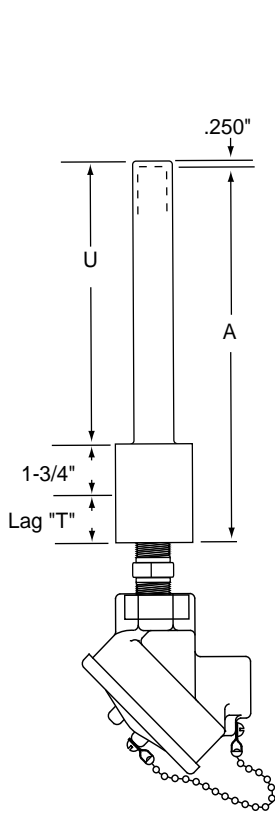

Representative of socketweld styles E and R (Field 5) with double ended bushing connector

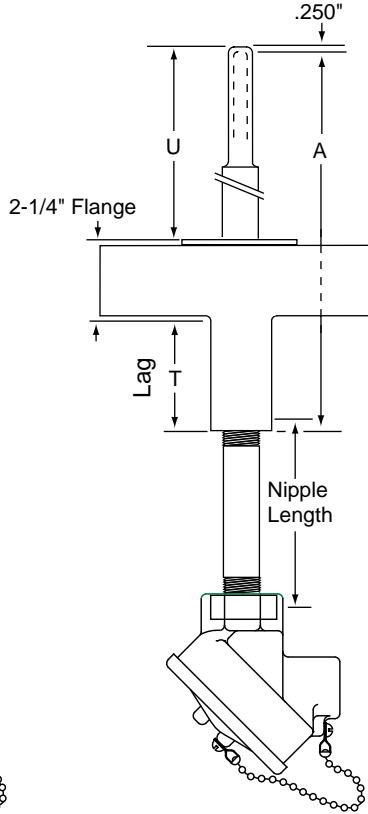

Representative of flanged styles D, Q, F, S, T, U (Field 5) with nipple connector

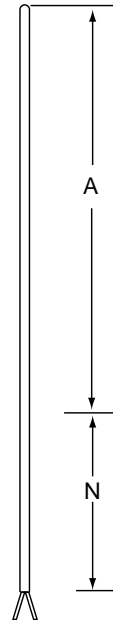

Representative of element only (Field 5). Measure "A" dimension when ordering replacement element.

### Fields 1, 2, 3, 4. THERMOCOUPLE TYPE, ELEMENTS, JUNCTION STYLE

☞ Complete Fields 5 through 13 to determine length.

	Type	Elements	Junction	Sheath	Diameter
J51W -	J	single	grounded	304 SS	0.188"
J51V -	J	dual	grounded	304 SS	0.188"
J51D -*	J	single	ungrounded	304 SS	0.188"
J51D -**	J	dual	isolated	304 SS	0.188"
J61W -	J	single	grounded	304 SS	0.250"
J61V -	J	dual	grounded	304 SS	0.250"
J61D -*	J	single	ungrounded	304 SS	0.250"
J61D -**	J	dual	isolated	304 SS	0.250"
J52W-	J	single	grounded	Inconel 600	0.188"
J52D -*	J	single	ungrounded	Inconel 600	0.188"
J62W-	J	single	grounded	Inconel 600	0.250"
J62V -	J	dual	grounded	Inconel 600	0.250"

# Thermowells and Assemblies

## Ordering Information (continued)

	Type	Elements	Junction	Sheath	Diameter
J62D -*	J	single	ungrounded	Inconel 600	0.250"
J62D -**	J	dual	isolated	Inconel 600	0.250"
J53W-	J	single	grounded	316 SS	0.188"
J53D -*	J	single	ungrounded	316 SS	0.188"
J63W-	J	single	grounded	316 SS	0.250"
J63V -	J	dual	grounded	316 SS	0.250"
J63D -*	J	single	ungrounded	316 SS	0.250"
J63D -**	J	dual	isolated	316 SS	0.250"
K51W-	K	single	grounded	304 SS	0.188"
K51D -*	K	single	ungrounded	304 SS	0.188"
K61W-	K	single	grounded	304 SS	0.250"
K61D -*	K	single	ungrounded	304 SS	0.250"
K52W-	K	single	grounded	Inconel 600	0.188"
K52V -	K	dual	grounded	Inconel 600	0.188"
K52D -*	K	single	ungrounded	Inconel 600	0.188"
K52D -**	K	dual	isolated	Inconel 600	0.188"
K62W-	K	single	grounded	Inconel 600	0.250"
K62V-	K	dual	grounded	Inconel 600	0.250"
K62D -*	K	single	ungrounded	Inconel 600	0.250"
K62D -**	K	dual	isolated	Inconel 600	0.250"
K53W-	K	single	grounded	316 SS	0.188"
K53D -	K	single	ungrounded	316 SS	0.188"
K63W-	K	single	grounded	316 SS	0.250"
K63V -	K	dual	grounded	316 SS	0.250"
K63D -*	K	single	ungrounded	316 SS	0.250"
K63D -**	K	dual	isolated	316 SS	0.250"
E51W-	E	single	grounded	304 SS	0.188"
E51D -*	E	single	ungrounded	304 SS	0.188"
E61W-	E	single	grounded	304 SS	0.250"
E61D -*	E	single	ungrounded	304 SS	0.250"
E63W-	E	single	grounded	316 SS	0.250"
E63D -*	E	single	ungrounded	316 SS	0.250"
T51W-	T	single	grounded	304 SS	0.188" (Obsolete)
T51D -	T	single	ungrounded	304 SS	0.188" (Obsolete)
T61W-	T	single	grounded	304 SS	0.250" (Obsolete)
T61D -	T	single	ungrounded	304 SS	0.250" (Obsolete)
T63W-	T	single	grounded	316 SS	0.250" (Obsolete)
T63V-	T	dual	grounded	316 SS	0.250" (Obsolete)
T63D -	T	single	ungrounded	316 SS	0.250" (Obsolete)

Note: Code "D" in Field 4 represents either of two different junction styles.

Therefore you must specify the desired style:

\*Specify code "W-2" on order. (W-2 = single element, ungrounded junction)

\*\*Specify code "V-3" on order. (V-3 = dual element, isolated junction)

### Fields 5 through 12. THERMOWELL AND OPTIONS

00000-0-00 None. Element, or element with head and connection only.  
 XXXXX-X-XX Complete Thermowell Assembly. See page 5-10

### Fields 13 through 15. CONNECTION, COLD END TERMINATION

0-00 None. Element only  
 X-XX Element with head and connection, or  
 complete thermowell assembly, see page 5-12

# Thermowells and Assemblies

## Ceramic Insulated Thermocouple Element (for wells with 0.385" bore only)

### Ordering Information

Model No.     -      -    -  -

Field No.            1    2    3    4        5    6    7    8    9        10 11 12    13    14 15

#### Fields 1, 2, 3. THERMOCOUPLE TYPE; WIRE GAUGE

 Complete Fields 5 through 13 to determine length.

	Type	Wire	Gauge	Limits
J14 -	J	Iron-Constantan	14	standard
J15 -	J	Iron-Constantan	14	special
J20 -	J	Iron-Constantan	20	standard
J21 -	J	Iron-Constantan	20	special
K14 -	K	Chromel-Alumel	14	standard
K15 -	K	Chromel-Alumel	14	special
K20 -	K	Chromel-Alumel	20	standard
K21 -	K	Chromel-Alumel	20	special
E14 -	E	Chromel-Constantan	14	standard
E15 -	E	Chromel-Constantan	14	special
E20 -	E	Chromel-Constantan	20	standard
E21 -	E	Chromel-Constantan	20	special
T14 -	T	Copper-Constantan	14	standard
T15 -	T	Copper-Constantan	14	special
T20 -	T	Copper-Constantan	20	standard
T21 -	T	Copper-Constantan	20	special

#### Field 4. NUMBER OF ELEMENTS AND JUNCTION STYLE

- W - Single, twisted, grounded
- V - Dual, twisted, grounded
- 2 - Single, twisted, ungrounded
- 3 - Single, butt welded, grounded
- 4 - Single, butt welded, ungrounded
- 5 - Dual common, butt welded, ungrounded
- 6 - Dual isolated, butt welded, ungrounded

#### Fields 5 through 12. THERMOWELL AND OPTIONS

- 00000-0-00            None. Element, or element with head and connection only.
- XXXXX-X-XX            Complete thermowell assembly. See page 5-10

#### Fields 13 through 15. CONNECTION, COLD END TERMINATION

- 0-00                    None. Element only.
- X-XX                    Element with head and connection, or complete thermowell assembly, see page 5-12

# Thermowells and Assemblies

## Resistance Temperature Detector Element

### Ordering Information

**Model No.**     -      -    -

Field No.      1    2    3    4    5    6    7    8    9    10 11 12    13    14 15

#### Fields 1, 2, 3. ELEMENT SPECIFICATIONS

 Complete Fields 5 through 13 to determine length.

<u>Description</u>	<u>Accuracy</u>	<u>Rating</u>
R51 - 0.00391 $\Omega/\Omega/^\circ\text{C}$	0.25%	500°F
R52 - 0.00391 $\Omega/\Omega/^\circ\text{C}$	0.10%	500°F
R53 - 0.00391 $\Omega/\Omega/^\circ\text{C}$	0.25%	932°F
R54 - 0.00391 $\Omega/\Omega/^\circ\text{C}$	0.10%	932°F
R71 - 0.00385 $\Omega/\Omega/^\circ\text{C}$	0.25%	500°F
R72 - 0.00385 $\Omega/\Omega/^\circ\text{C}$	0.10%	500°F
R73 - 0.00385 $\Omega/\Omega/^\circ\text{C}$	0.25%	932°F
R74 - 0.00385 $\Omega/\Omega/^\circ\text{C}$	0.10%	932°F

#### Field 4. NUMBER OF ELEMENTS AND WIRES

- 1 - Single element, 3 wire
- 2 - Dual element, 3 wire
- 5 - Single element, 4 wire

#### Fields 5 through 12. THERMOWELL AND OPTIONS

- 00000-0-00      None. Element, or element with head and connection only.
- XXXXXX-X-XX    Complete thermowell assembly. See page 5-10

#### Fields 13 through 15. CONNECTION, COLD END TERMINATION

- 0-00      None. Element, only.
- X-XX      Element with head and connection, or complete thermowell assembly, see page 5-12

# Thermowells and Assemblies

## Thermowell

### Ordering Information

**Model No.**     -       -    -  -    
Field No.      1   2   3   4        5   6   7   8   9        10 11 12    13    14 15

#### Fields 1, 2, 3, 4. BASE MODEL

TH00 - Thermowell only

XXXX - MgO Insulated Thermocouple. See page 5-6

XXXX - Ceramic Insulated Thermocouple. See page 5-8

XXXX - RTD. See page 5-9

#### Field 5. THERMOWELL STYLE

See thermowell illustrations on pages 5-14, 5-15;  
see compatibility table after Fields 10, 11.

##### **Threaded; 0.260" Bore**

M - Tapered shank

N - Straight shank

P - Straight shank, reduced tip

##### **Socketweld; 0.260" Bore**

R - Straight shank, reduced tip

##### **Flanged; 0.260" Bore**

Q - Straight shank

U - Straight shank, reduced tip

T - Tapered shank

S - Straight shank – Vanstone

##### **Threaded; 0.385" Bore**

A - Tapered shank

B - Straight shank

##### **Socketweld; 0.385" Bore**

E - Straight shank

##### **Flanged; 0.385" Bore**

D - Straight shank

F - Straight shank – Vanstone

#### Field 6. LAG ("T" DIMENSION)

 This Field required for Fields 10, 11. See thermowell illustrations

X - Actual whole inches up to 8"

9 - Other. Specify on order (Consult Factory)

#### Fields 7, 8, 9. INSERTION LENGTH ("U" DIMENSION)

 These Fields required for Fields 10, 11. See thermowell illustrations

##### **Fields 7, 8**

XX - Actual whole inches (minimum 02)

##### **Field 9**

0 - No increment

5 - 1/2" increment

Examples: 100 = 10"; 105 = 10-1/2"

Thermowell illustrations  
and dimensions on  
pages 5-14, 5-15

# Thermowells and Assemblies

## Ordering Information (continued)

### Fields 10, 11. THERMOWELL MATERIAL, MOUNTING

☞ These Fields required for Fields 1, 2, 3, 4 when element is specified.

☞ Use insertion length specified in Fields 7, 8, 9; use lag length specified in Field 6. See compatibility table below.

Note: Additional materials available. See page 5-16.

#### **304 Stainless Steel – Threaded or Socketweld**

- A L - 1/2" NPT
- A A - 3/4" NPT (or NPS socketweld)
- A B - 1" NPT (or NPS socketweld)
- A C - 1-1/4" NPT

#### **304 Stainless Steel – Flanged**

- A D - 1" pipe, 150 pounds
- A E - 1-1/2" pipe, 150 pounds
- A F - 1-1/2" pipe, 300 pounds
- A G - 1-1/2" pipe, 600 pounds
- A H - 1" pipe, Vanstone\*
- A J - 1-1/2" pipe, Vanstone\*

#### **316 Stainless Steel – Threaded or Socketweld**

- B L - 1/2" NPT
- B A - 3/4" NPT (or NPS socketweld)
- B B - 1" NPT (or NPS socketweld)
- B C - 1-1/4" NPT

#### **316 Stainless Steel – Flanged**

- B D - 1" pipe, 150 pounds
- B E - 1-1/2" pipe, 150 pounds
- B F - 1-1/2" pipe, 300 pounds
- B G - 1-1/2" pipe, 600 pounds
- B H - 1" pipe, Vanstone\*
- B J - 1-1/2" pipe, Vanstone\*

#### **C-1018 (Carbon Steel) – Threaded or Socketweld**

- C L - 1/2" NPT
- C A - 3/4" NPT (or NPS socketweld)
- C B - 1" NPT (or NPS socketweld)
- C C - 1-1/4" NPT

#### **C-1018 (Carbon Steel) – Flanged**

- C D - 1" pipe, 150 pounds
- C E - 1-1/2" pipe, 150 pounds
- C F - 1-1/2" pipe, 300 pounds
- C G - 1-1/2" pipe, 600 pounds
- C H - 1" pipe, Vanstone\*
- C J - 1-1/2" pipe, Vanstone\*

#### **Brass – Threaded or Socketweld**

- U L - 1/2" NPT
- U A - 3/4" NPT (or NPS socketweld)
- U B - 1" NPT (or NPS socketweld)
- U C - 1-1/4" NPT

#### **Brass – Flanged**

- U H - 1" pipe, Vanstone\*
- U J - 1-1/2" pipe, Vanstone\*

\*Flange not part of Vanstone thermowell; order separately.

Consult factory for availability.

### Compatibility Table

Field 10. Material	Field 11. Mounting	Field 5. Style
A, B, C or U	L, A, B or C	A, B, M, N or P (Threaded)
	A or B	E or R (Socketweld)
	H or J	F or S (Vanstone)
A, B or C	D, E, F or G	D, Q, T or U (Flanged)

# Thermowells and Assemblies

## Ordering Information (continued)

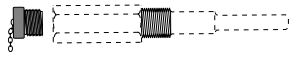

Plug and chain  
(code 1 or 2)

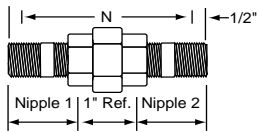
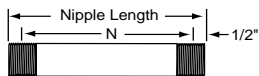

Field 13, Code	"N" =
0	0"
A, C, E, J	3"
B, D	Nipple length - 1"
F, K	Combined length of Nipple 1 and Nipple 2
L	Not applicable
G, H	Not applicable

### Field 12. OPTIONS

- 0 - None
- 1 - Brass plug and chain
- 2 - 304 stainless steel plug and chain
- 3 - Internal hydrostatic test
- 4 - Dye penetration test
- 5 - Full penetration weld
- 6 - Material certification
- 7 - Stress relief
- 9 - Two or more of the above listed options. Specify on order.

### Field 13. HEAD TO WELL CONNECTION

- 0 - None. Thermowell only, or element only. If element only, indicate the code from the following list that identifies the connector used on the present assembly.
- A - 4" black steel nipple
- B - Black steel nipple; specify length on order.
- C - 4" stainless steel nipple
- D - Stainless steel nipple; specify length on order.
- E - 4" black steel nipple and union
- F - Steel nipples and union; specify nipple lengths.
- J - 4" Galvanized steel nipples and union
- K - Galvanized nipples and union; specify nipple lengths.
- L - 1/2" NPT double ended bushing

### Fields 14, 15. COLD END TERMINATION

#### Thermowell Assembly; or Element with Head

Ceramic insulated elements are not available spring loaded. Use MgO insulated elements instead.

- 00 - None
- 08 - General purpose, cast iron head, non-spring loaded (Obsolete use code "10")
- 23 - General purpose, cast iron head, spring loaded (Obsolete use code "25")
- 09 - General purpose, aluminum head, non-spring loaded (Obsolete use code "27")
- 24 - General purpose, aluminum head, spring loaded (Obsolete use code "28")
- 10 - Weatherproof, cast iron head, non-spring loaded
- 25 - Weatherproof, cast iron head, spring loaded
- 22 - Explosionproof head, non-spring loaded
- 26 - Explosionproof head, spring loaded
- 27 - Weatherproof, aluminum head, non-spring loaded
- 28 - Weatherproof, aluminum head, spring loaded
- 32 - Transmitter ready, aluminum, non-spring loaded
- 34 - Transmitter ready, aluminum, spring loaded

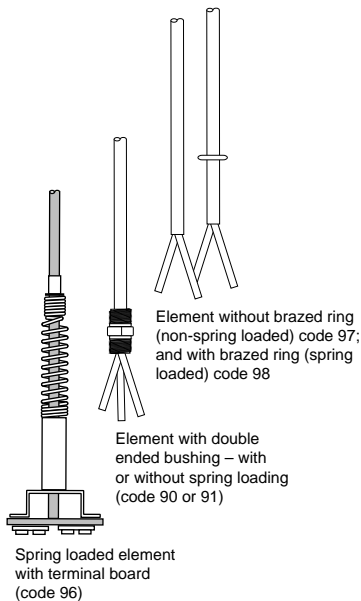

# Thermowells and Assemblies

## Ordering Information (continued)

### Ordering replacement elements for thermowells

- Code 90 – Double ended bushing, not spring loaded**
- Code 91 – Double ended bushing, spring loaded**

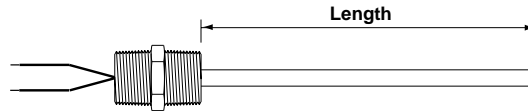

Select the type of element and enter the proper code in the first four digits of the model number. Example: J61W-  
 Enter "0" in fields 5 and 6 of the model number. Example: J61W-00  
 Measure the length of the old element as illustrated above. Enter that length in fields 7, 8 and 9. Use field 9 for fractions of  
 an inch. Example: For 6-1/2 inch length, enter J61W-00065-  
 Enter "0" in fields 10, 11, 12 and 13 of the model number. Example: J61W-00065-000-0-  
 Enter code "90" or code "91" in fields 14 and 15 of the model number. Example: J61W-00065-000-0-90

- Code 96 – Spring loaded with terminal board**
- Code 97 – Element only, not spring loaded**
- Code 98 – Element only, with ring for spring loading**

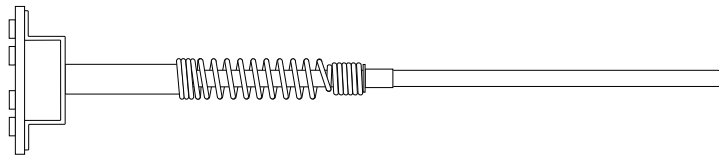

These elements are more difficult to specify. The following information is required:  
 The "A" dimension of the well  
 The "N" dimension which is the length of the head to well connection  
 The style of the thermocouple head

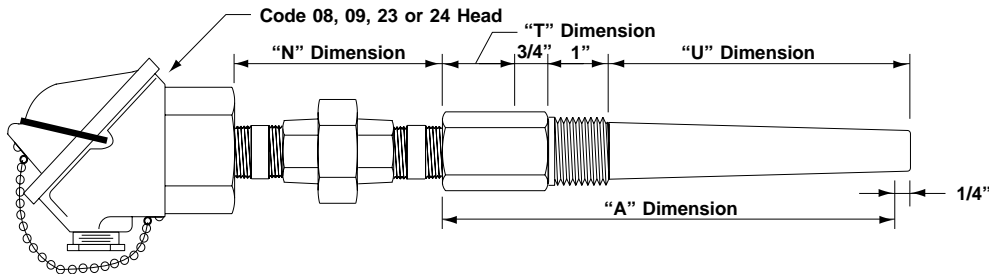

The "A" dimension is the overall length of the well less 1/4". For thermowell codes A, B, E, M, N, P or R (field 5 of the model number) add the "U" dimension plus the "T" dimension plus 1-1/2". For codes D, F, Q, S, T or U, add the "U" dimension plus 2". If the model number is not known, insert a piece of welding rod into the well and measure the "A" dimension.

The "N" dimension is the length of the head to well connector less allowance for thread immersion. For connector codes A, C, E or J, the length is 3-1/2". For connector codes B, D, F or K, the "N" dimension will have to be measured.

The various styles of thermocouple heads have different internal dimensions that impact the length of the element. The proper code for the head (fields 14 and 15) should be specified by description when ordering the element.

Select the type of element and enter the proper code in the first four digits of the model number. Example: J61W-  
 Enter "0" in fields 5 and 6 of the model number. Example: J61W-00  
 Calculate the length of the element by adding the "A" and "N" dimensions. Enter that length in fields 7, 8 and 9. Use field 9  
 for fractions of an inch. Example: For 6-1/2 inch length, enter J61W-00065-  
 Enter "0" in fields 10, 11, 12 and 13 of the model number. Example: J61W-00065-000-0-  
 Enter code "96" or code "91" in fields 14 and 15 of the model number. Example: J61W-00065-000-0-96, head code = 24.

# Thermowells and Assemblies

## Thermowell Styles

### Style M and A

Mounting	Diameter "Q"
3/4" NPT	0.875"
1" NPT	1.062"
1-1/4" NPT	1.437"

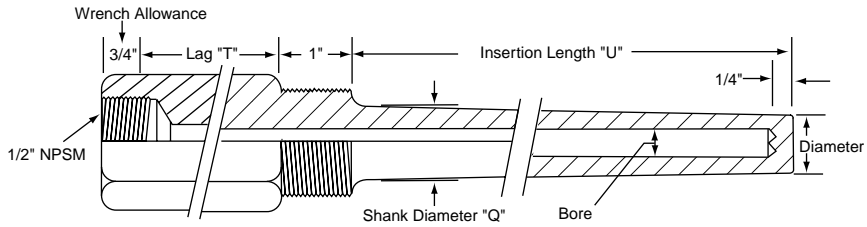

### Style P

Mounting	Diameter "Q"
3/4" NPT	0.750"
1" NPT	0.875"
1-1/4" NPT	1.437"

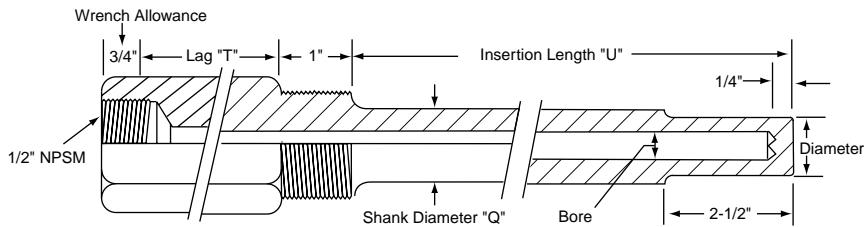

### Style R

Mounting	Diameter "Q"
3/4" Pipe Size	0.750"
1" Pipe Size	0.875"

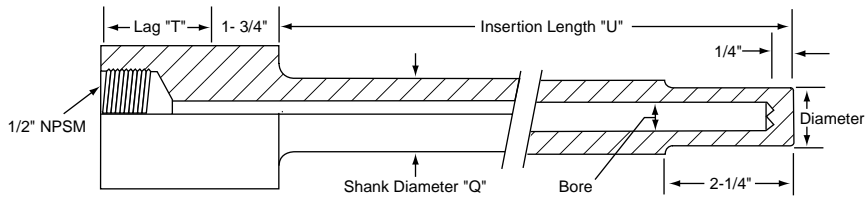

### Style N and B

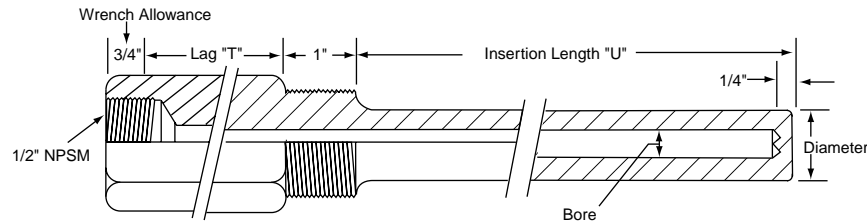

### Style Q and D

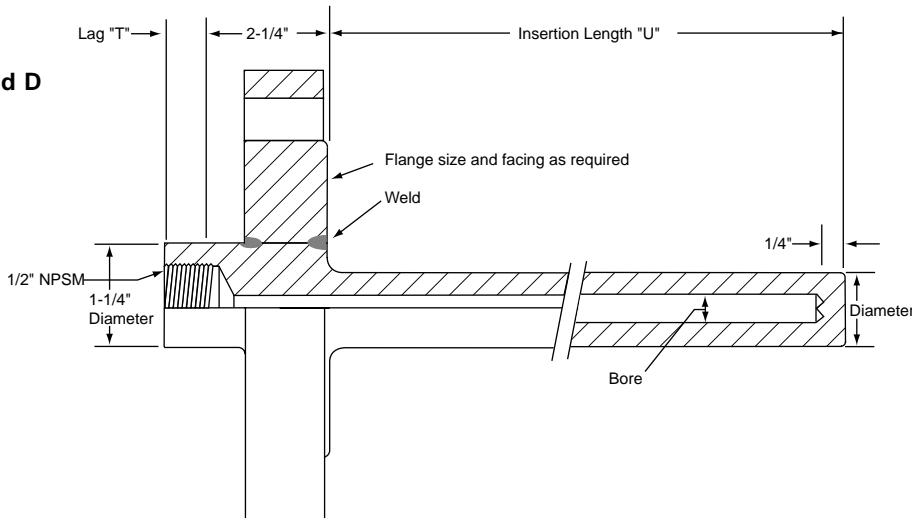

Style	Tip Diameter
A, B, E	0.766"
D, F	0.875"
M, N, T	0.625"
P, R, U	0.500"
Q, S	0.750"

# Thermowells and Assemblies

## Thermowell Styles (continued)

Style	Tip Diameter
A, B, E	0.766"
D, F	0.875"
M, N, T	0.625"
P, R, U	0.500"
Q, S	0.750"

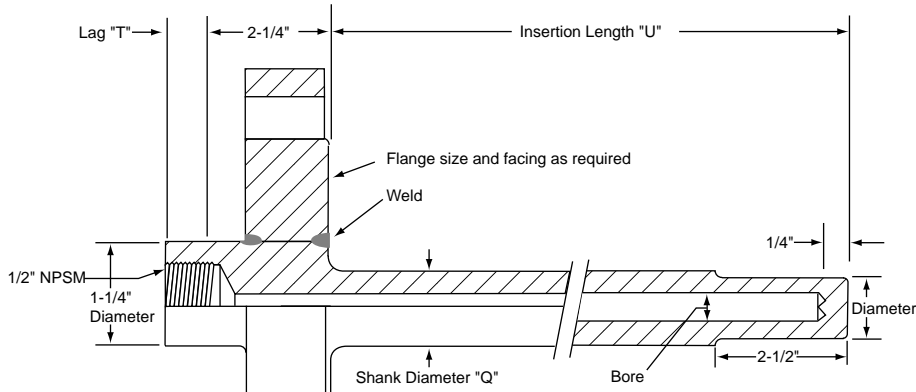

**Style U**  
Dia. "Q" = 0.750"

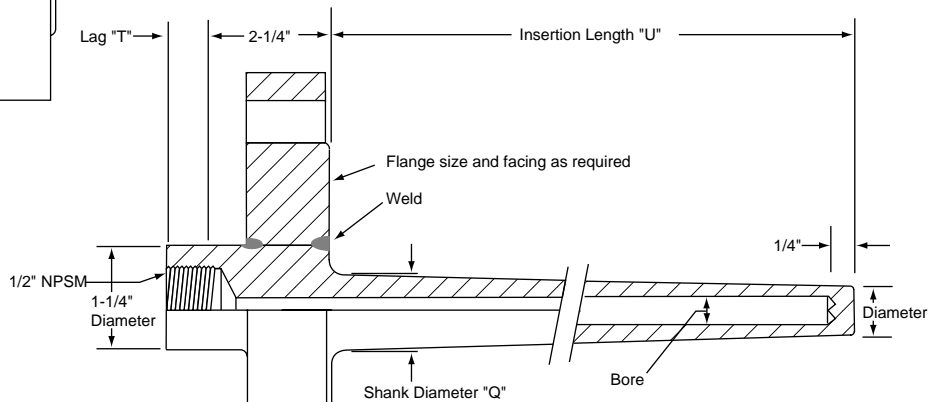

**Style T**  
Dia. "Q" = 0.875"

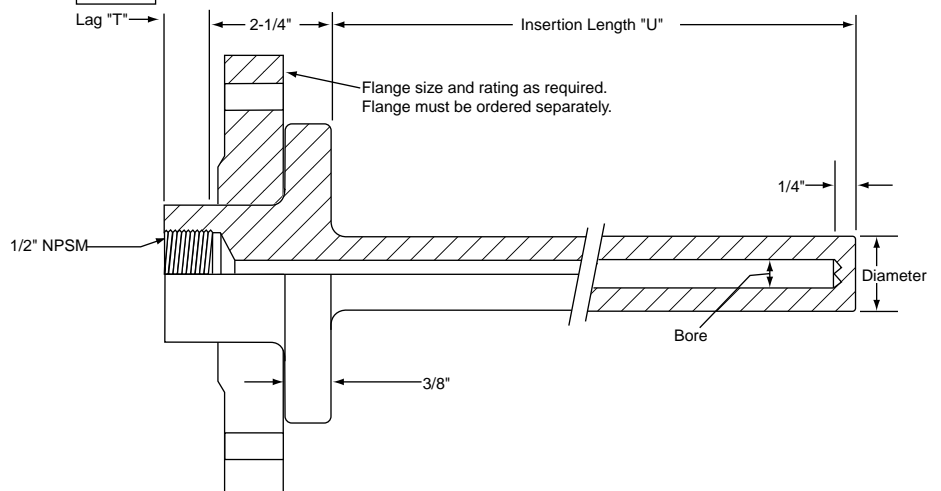

**Style S and F**

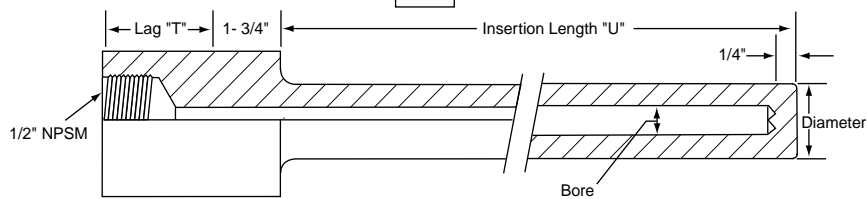

**Style E**

Thermowells

# Thermowells and Assemblies

## Specifications

### Velocity Ratings

In most cases, well failures are not due to the affect of pressure and temperature. Calculations necessary to provide adequate strength under given conditions are familiar enough to permit proper choice of wall thickness and material.

Less familiar, and more dangerous, are the vibrational affects to which wells are subjected. Fluid, flowing by the well, forms a turbulent wake (the Von Karman trail) which has a definite frequency base on the diameter of the well and the velocity of the fluid. The well must have sufficient stiffness so that the wake frequency will never equal the natural frequency of the well. If the two frequencies coincide, the well will vibrate and break in the piping.

On the following pages, a recommended maximum velocity rating can be found for every standard well length and material cataloged. To reduce the complexity of presenting this information, the ratings given are based on operating temperatures of 1000°F for wells of carbon steel (C-1018), AISI 304 and AISI 316. Values for brass wells are based on 350°F operation. Limits of monel wells are based on 900°F service. Slightly higher velocity is possible at lower temperatures.

### Materials Available

Wells are available in the materials listed below. Thermowells are manufactured form hex stock except as noted. Wrench flats are milled on round stock.

Wells of these materials is readily available; ratings are shown in this document:

<b>Code (Field 10)</b>	<b>Material</b>
A	304 stainless steel
B	316 stainless steel
C	C-1018 carbon steel
U	Brass*

Wells of these materials are available; contact factory for rating information:

E	309 stainless steel
F	310 stainless steel
G	321 stainless steel
H	347 stainless steel
J	410 stainless steel
K	446 stainless steel
L	Inconel 600 (round stock)
M	Incoloy 800 (round stock)
N	Hastelloy B (round stock)
P	Hastelloy C (round stock)
R	Nickel 200 (round stock)
D	Monel
S	F-11 carbon steel
T	F-22 carbon steel
V	Titanium
W	Teflon (round stock)*
Y	Polyvinyl chloride (PVC)*

\*available only in styles A, B, F, M, N, P and S illustrated in the preceding pages.

# Thermowells and Assemblies

## Specifications (continued)

### Pressure-Temperature Ratings (Pounds per square inch)

#### Styles A, B, E, P, N, R (Field 5)

	<u>70°F</u>	<u>200°F</u>	<u>400°F</u>	<u>600°F</u>	<u>800°F</u>	<u>1000°F</u>	<u>1200°F</u>
Brass	5000	4200	1000	n/a	n/a	n/a	n/a
Carbon Steel	5200	5000	4800	4600	3500	1500	n/a
304 Stainless Steel	7000	6200	5600	5400	5200	4500	1650
316 Stainless Steel	7000	7000	6400	6200	6100	5100	2500
Monel	6500	6000	5400	5300	5200	1500	n/a

#### Style M

	<u>70°F</u>	<u>200°F</u>	<u>400°F</u>	<u>600°F</u>	<u>800°F</u>	<u>1000°F</u>	<u>1200°F</u>
Carbon Steel	5950	5750	5450	5250	4000	1750	n/a
304 Stainless Steel	7800	7050	6400	6150	6000	5190	1875
316 Stainless Steel	7800	7800	7250	7100	6950	5800	2720
Monel	7450	6850	6150	6100	5940	1750	n/a

### Maximum Flange Pressure

#### Styles D, F, Q, and S

Carbon Steel:	2500 psi to 900°F.
304 Stainless Steel:	2500 psi to 1050°F
316 Stainless Steel:	2500 psi to 1125°F
Monel:	2500 psi to 900°F.

### Shank and Tip Diameters

<u>Style</u>	<u>Mounting</u>	<u>Diameter "Q"</u>
A & M	3/4" NPT	0.875"
	1" NPT	1.062"
	1-1/4" NPT	1.437"
P	3/4" NPT	0.750"
	1" NPT	0.875"
	1-1/4" NPT	1.437"
R	3/4" Pipe Size	0.750"
	1" Pipe Size	0.875"
T	Flange	0.875"
U	Flange	0.750"

### Tip Diameter "Q"

<u>Style</u>	
A, B, E	0.766"
D, F	0.875"
M, N	0.625"
P, R	0.500"
Q, S	0.750"
T	0.625"
U	0.500"

# Thermowells and Assemblies

## Specifications (continued)

### Maximum Fluid Velocity

Where single values appear in the velocity tables, these may be considered safe for water, steam, air or gas. In shorter insertion lengths, consideration is given to the velocity pressure affect of water flowing at higher velocities. The values in parenthesis represent safe velocities for water flow; the unbracketed value may be used for steam, air, gas and similar density fluids.

The values printed are extremely conservative and intended primarily as a guide. Wells are also safe if the resonant frequency is well below the wake frequency or if the fluid velocity is constantly fluctuating through the critical velocity point. Nevertheless, if the installation is not hampered by a sufficiently stiff well, we recommend the values give not be exceeded.

	Insertion Length "U"							
	2-1/2"	4-1/2"	7-1/2"	10-1/2"	13-1/2"	16-1/2"	19-1/2"	22-1/2"
<b>Style A, 1" NPT Mounting</b>								
Carbon Steel	410 (270)	249 (150)	90.3	45.6	27.8	18.5	13.2	9.8
304 & 316 SS	483 (350)	272 (208)	97.3	49.7	30.4	20.3	14.5	10.7
Monel	396 (300)	214 (167)	77.5	39.2	23.8	16.0	10.3	7.7
<b>Style B, 3/4" NPT and 1" NPT Mounting</b>								
Brass	290 (145)	150 (80)	54.1 (48)	27.6	16.7	11.1	8.0	6.0
Carbon Steel	326 (260)	192 (144)	69.5	35.4	20.5	14.3	10.3	7.7
304 & 316 SS	349 (360)	199	71.9	36.6	21.2	14.8	10.7	8.0
Monel	316 (320)	189 (178)	68.1	34.8	20.8	14.0	10.0	7.5
<b>Style M, 3/4" NPT Mounting</b>								
Carbon Steel	386 (175)	180 (97.2)	65.3 (58.3)	33.0	20.1	13.4	9.6	7.1
304 & 316 SS	440 (243)	197 (135)	71.2	36.0	22.0	14.7	0.5	7.8
Monel	354 (195)	155 (108)	56.1	28.4	17.3	11.6	7.5	5.6
<b>Style M, 1" NPT Mounting</b>								
Carbon Steel	448 (289)	209 (161)	75.7	38.4	23.3	15.5	11.1	8.2
304 & 316 SS	490 (403)	228 (225)	82.5	41.8	25.5	17.1	12.2	9.1
Monel	410 (322)	179 (178)	65.1	33.0	20.1	13.5	8.7	6.5
<b>Style P, 3/4" NPT Mounting</b>								
Brass	207 (59.3)	89.1(39.8)	32.2 (23.9)	16.4	9.9	6.6	4.8	3.6
Carbon Steel	290 (106)	123 (71.2)	44.9 (42.7)	22.8	13.8	9.3	6.7	4.9
304 & 316 SS	300 (148)	128 (99.3)	46.4	23.6	14.3	9.6	6.9	5.1
Monel	261 (118)	112 (79.8)	40.6	20.7	12.4	8.3	6.1	4.5
<b>Style P, 1" NPT Mounting</b>								
Brass	207 (59.3)	102 (47.6)	37.0 (28)	18.8	11.4	7.6	5.5	4.1
Carbon Steel	290 (106)	143 (84.3)	51.6 (50.6)	26.2	15.9	10.6	7.6	5.7
304 & 316 SS	300 (148)	148 (117)	53.5	27.2	16.5	11.0	7.9	5.9
Monel	261 (118)	128 (99.3)	46.7	23.7	14.4	9.5	6.9	5.1
<b>Style R, 3/4" NPT Mounting</b>								
Carbon Steel	290 (106)	123 (71.2)	44.9 (42.7)	22.8	13.8	9.3	-	4.9
304 & 316 SS	300 (148)	128 (99.3)	46.4	23.6	14.3	9.6	-	5.1
<b>Style R, 1" NPT Mounting</b>								
Carbon Steel	290 (106)	143 (84.3)	51.6 (50.6)	26.2	15.9	10.6	-	5.7
304 & 316 SS	300 (148)	148 (117)	53.5	27.2	16.5	11.0	-	5.9
<b>Style E, 3/4" NPT and 1" NPT Mounting</b>								
Carbon Steel	426 (260)	192 (144)	69.5	35.4	20.5	14.3	-	7.7
304 & 316 SS	449 (360)	199	71.9	36.6	21.1	14.8	-	8.0

	Insertion Length "U"						
	2"	4"	7"	10"	13"	16"	22"
<b>Styles Q and S</b>							
Carbon Steel	404 (129)	184 (71.2)	67.0 (42.7)	34.0	20.6	13.7	7.4
304 & 316 SS	430 (179)	192 (99.3)	69.7 (59.6)	35.4	21.5	14.3	7.7
Monel	350 (143)	168 (79.8)	61 (47.7)	31.0	18.8	12.5	6.7
<b>Styles D and F</b>							
Carbon Steel	410 (152)	248 (84.3)	91.3 (50.6)	45.7	27.6	18.5	10.0
304 & 316 SS	444 (211)	258 (117)	95.2 (70.3)	47.6	28.8	19.3	10.4
Monel	338 (168)	226 (93.3)	83.3 (56.0)	41.6	25.2	16.9	9.1



# Thermowells and Assemblies

## Specifications (continued)

### Comparative Corrosion Ratings, Limitations (continued)

	Carbon Steel	Inconel	Monel	Nickel	303, 304 SS	316 SS	Teflon
Barium Chloride, 5%	C	A	A	A	A	A	A
Barium Chloride, >5% Hot	D	B	A	A	C3	B3	A
Barium Hydroxide	C	A	A	A	A	A	A
Barium Nitrate	C	B	C	C	A	A	A
Beer, 160°F	C	A	A	A	A	A	A
Beet Sugar, Liquor, Hot	B	A	A	A	A	A	A
Benzene, Hot	B	A	A	A	A	A	A
Benzoic Acid	B	A	A	A	A	A	A
Blood	D	A	A	A	A	A	A
Borax, Hot	B	A	A	B	A	A	A
Boric Acid, 5%, Hot	D	A	B	B	B	B	A
Bromine, Dry Gas	D	B	A	A	D	D	A
Bromine, Moist Gas	D	D	C	C	D	D	A
Buttermilk	D	A	A	A	A	A	A
Butyric Acid, Dilute	X	A	A	A	A	A	A
Butyric Acid, Hot, Conc.	D	B	B	C	C	B	A
Calcium Bisulfite, Hot	D	D	D	D	C	B	A
Calcium Chloride, Dilute	C	A	A	A	B3	A3	A
Calcium Hydroxide, 10% Boiling	D	A	A	A	A	A	A
Calcium Hydroxide, 20% Boiling	D	A	A	A	A	A	A
Calcium Hydroxide, 30% Boiling	D	A	A	A	C	B	A
Calcium Hypochloride, <2%	C	B	C	C	C3	B3	A
Carbolic Acid, 90%	C	A	B	A	A	A	A
Carbon Dioxide, Dry	B	A	A	A	A	A	A
Carbon Disulphide	B	A	B	B	A	A	A
Carbon Tetrachloride, Dry, Hot	C	A	A	A	B	A	A
Carbonic Acid, Saturated	D	A	A	A	A	A	A
Chloroacetic Acid	D	B	B	B	D	C	A
Chloric Acid	D	C	C	C	D	C	A
Chlorinated Water, Sat.	D	C	C	C	D	C3	A
Chlorine, Dry Gas	B	A	A	A	B	B	A
Chlorine, Moist Gas	D	D	C	C	D	C	A
Chlorosulfonic Acid, Dilute	D	B	B	A	D	B	A
Chromic Acid, Dilute	B	B	B	B	B	A	A
Chromic Acid, <10% Boiling	D	C	C	D	C	B	A
Chromic Acid, >10% Boiling	D	C	D	D	D	C	A
Citric Acid, Dilute	D	A	A	B	A	A	A
Citric Acid, Hot, Concentrated	D	B	B	B	C	B	A
Copper Nitrate, Hot, Concentr'd	D	C	D	D	A	A	A
Copper Sulfate, Hot, Concentr'd	D	B	C	C	B	A	A
Creosote, Hot	B	A	A	A	A	A	A
Cupric Chloride, <2%	D	C	B	B	B3	B3	A
Cupric Chloride, 5%	D	D	D	C	D	C3	A
Dichlorethane, Boiling	D	B	A	A	B	B	A
Ethyl Chloride	A	A	A	A	A	A	A
Ethylene Glycol	A	A	A	A	A	A	A
Fatty Acids, 145°F	C	A	A	A	B	A	A
Ferric Chloride, <1%	D	B	C	B	C3	B3	A
Ferric Chloride, >1%	D	D	D	D	D	D	A
Ferric Chloride, <1%, Boiling	D	D	D	D	D	D	A
Ferric Chloride, >1%, Boiling	D	D	D	D	D	D	A
Ferric Nitrate, 5%	D	C	D	D	B	A	A
Ferric Sulfate, 5%	D	B	C	C	B3	A	A
Ferrous Sulfate, 10%	C	B	A	A	A	A	A
Fluorine, Dry Gas	C	A	A	A	C	B	A
Fluorine, Dry, 300°F	D	B	A	A	D	C	D

# Thermowells and Assemblies

## Specifications (continued)

### Comparative Corrosion Ratings, Limitations (continued)

	Carbon Steel	Inconel	Monel	Nickel	303, 304 SS	316 SS	Teflon
Fluorine, Moist Gas	D	B	A	B	D	D	A
Formaldehyde 40%	C	A	A	A	B	A	A
Formic Acid, <50%	D	A	B	B	B	A	A
Formic Acid, >50%	D	B	B	B	B	A	A
Formic Acid, <50%, Hot	D	B	B	B	B	A	A
Formic Acid, >50%, Hot	D	B	B	B	C	B	A
Freon, Wet	C	B	A	A	C	C	A
Fuel Oil, 140°F	A	A	B	B	A	A	A
Furfural	B	B	B	B	B	B	A
Gasoline, Refined	A	A	A	A	A	A	A
Glycerine	A	A	A	A	A	A	A
Hydrochloric Acid, <1%	D	B	B	B	D	B	A
Hydrochloric Acid, 1-20%	D	C	B	B	D	D	A
Hydrochloric Acid, >20%	D	D	D	C	D	D	A
Hydrochloric Acid, <1/2%, 175°F	D	C	B	B	D	D	A
Hydrochloric Acid, 1/2-2%, 175°F	D	D	C	C	D	D	A
Hydrochloric Acid, >2%, 175°F	D	D	D	D	D	D	A
Hydrochloric Acid, <1/4%, Boiling	D	C	B	B	D	D	A
Hydrochloric Acid, 1/4-1%, Boiling	D	C	C	C	D	D	A
Hydrochloric Acid, >1%, Boiling	D	D	D	D	D	D	A
Hydrofluoric Acid, <40%	C	C	B	B	D	D	A
Hydrofluoric Acid, >40%	C	C	B	C	D	D	A
Hydrofluoric Acid, Boiling	D	D	B	C	D	D	A
Hydrofluosilic Acid	D	B	A	B	D	C	A
Hydrogen Chloride, Dry	B	A	A	A	D	C	A
Hydrogen Chloride, Moist	D	D	C	C	D	D	A
Hydrogen Fluoride, Dry	C	A	A	A	D	C	A1
Hydrogen Peroxide, Boiling	D	B	B	B	C	B	A
Hydrogen Sulfide, Dry	B	A	A	A	A	A	A
Hydrogen Sulfide, Moist	C	A	B	B	B	A	A
Iodine, Dry	D	A	A	A	D	B	A
Kerosene	A	A	A	A	A	A	A
Lactic Acid, 5%	D	A	B	B	B	A	A
Lactic Acid, 10%	D	A	B	B	B	A	A
Lactic Acid, Boiling, 5%	D	B	C	C	C	B	A
Lactic Acid, Boiling, 10%	D	B	C	C	D	B	A
Lead Acetate, Hot	D	B	B	C	A	A	A
Magnesium Chloride, Hot, 5%	D	A	A	A	C3	B3	A
Magnesium Hydroxide	B	A	A	A	A	A	A\
Magnesium Sulfate	B	B	A	B	A	A	A
Magnesium Sulfate, Boiling	C	C	A	B	A	A	A
Mercury	B	A	B2	A	A	A	A
Mercuric Chloride, <2%	D	D	D	D	D	D	A
Mercuric Chloride, <1/2%, Boiling	D	D	D	D	D	D	A
Mercuric Cyanide	D	B	D	B	B	B	A
Methyl Chloride, Dry	D	A	A	A	B	B	A
Milk	D	A	B	B	A	A	A
Molasses	B	A	A	A	A	A	A
Naptha	B	A	A	A	A	A	A
Nickel Chloride	D	B	B	B	C3	B3	A
Nickel Sulfate, Boiling	D	B	A	A	C	C	A
Nitric Acid, 20%	D	B	D	D	A	A	A
Nitric Acid, Fuming	D	B	D	D	B	B	A
Nitric Acid, Boiling, 20%	D	C	D	D	A	A	A
Nitric Acid, Boiling, 65%	D	D	D	D	B	B	A
Nitric Acid, Boiling, Conc.	D	D	D	D	D	D	A
Nitrous Acid	D	B	C	C	B	B	A

# Thermowells and Assemblies

## Specifications (continued)

### Comparative Corrosion Ratings, Limitations (continued)

	Carbon Steel	Inconel	Monel	Nickel	303, 304 SS	316 SS	Teflon
Oxalic Acid, <10%	C	A	A	A	A	A	A
Oxalic Acid, 10%	C	A	A	A	A	A	A
Oxalic Acid, Boiling, 10%	D	A	A	B	D	C	A
Oxalic Acid, Boiling, 50%	D	B	B	C	D	C	A
Phosphoric Acid (Ortho), <10%	D	A	B	B	B	A	A
Phosphoric Acid (Ortho), 10-50%	D	A	B	C	C	A	A
Phosphoric Acid (Ortho), >50%	D	A	B	C	C	A	A
Phosphoric Acid (Ortho), <20%,175°F	D	C	B	D	D	A	A
Phosphoric Acid (Ortho), >20%,175°F	D	D	B	D	D	B	A
Phosphoric Acid (Ortho),10%, Boiling	D	D	C	D	D	B	A
Phosphoric Acid (Ortho), 85%,Boiling	D	D	D	D	D	C	A
Picric Acid	C	D	D	D	A	A	A
Potassium Bromide	D	A	A	A	C3	B3	A
Potassium Carbonate	B	A	A	A	A	A	A
Potassium Chlorate	B	A	B	B	A	A	A
Potassium Chloride	D	A	A	B	A3	A3	A
Potassium Chloride, Hot	D	B	A	B	C3	B3	A
Potassium Cyanide	B	B	B	B	B	B	A
Potassium Dichromate, Conc.	C	B	B	C	A	A	A
Potassium Ferricyanide, 5%	C	B	B	B	A	A	A
Potassium Ferrocyanide, 5%	C	X	B	B	A	A	A
Potassium Hydroxide, 50%	B	A	A	A	A	A	A
Potassium Hydroxide, 30%, 175°F	D	A	A	A	A	A	A
Potassium Hydroxide, 50%, 175°F	D	A	A	A	B	A	A
Potassium Hydroxide, 30%, Boiling	D	A	A	A	B	A	A
Potassium Hydroxide, 50%, Boiling	D	A	A	A	B	A	A
Potassium Hypochlorite, Dilute	D	X	D	C	C3	B3	A
Potassium Permanganate, Dilute	B	B	A	A	A	A	A
Potassium Sulfate, Dilute	B	A	A	A	A	A	A
Potassium Sulfate, Dilute, Boiling	D	B	B	B	B	B	A
Potassium Sulfide, Saturated	C	A	C	A	A	A	A
Propane, Liquid and Gas	B	A	A	A	A	A	A
Pyrogalic Acid	B	B	A	A	A	A	A
Rosin, Molten	D	A	A	A	A	A	A
Salicylic Acid	D	B	B	B	B	B	A
Silver Bromide	D	C	B	C	B3	A3	A
Silver Chloride	D	C	B	C	D	D	A
Silver Nitrate	X	A	C	D	A	A	A
Sodium Acetate	C	A	A	A	A	A	A
Sodium Bisulfate	D	B	A	B	B	B	A
Sodium Bisulfate, 140°F	D	C	B	C	B	B	A
Sodium Bromide, Dilute	X	B	A	B	B3	A3	A
Sodium Carbonate, 5%, Hot	B	A	A	A	A	A	A
Sodium Chloride, Dilute	C	A	A	A	A	A	A
Sodium Chloride, Saturated, Boiling	D	A	A	A	C3	B3	A
Sodium Cyanide	B	B	A	B	B	B	A
Sodium Fluoride, 5%	D	B	A	A	B3	A3	A
Sodium Hydroxide, 50%	B	A	A	A	A	A	A
Sodium Hydroxide, <40%,175°F	D	A	A	A	A	A	A
Sodium Hydroxide,40-80%,175°F	D	A	A	A	A	A	A
Sodium Hydroxide, <30%, Boiling	D	A	B	A	A	A	A

# Thermowells and Assemblies

## Specifications (continued)

### Comparative Corrosion Ratings, Limitations (continued)

	Carbon Steel	Inconel	Monel	Nickel	303, 304 SS	316 SS	Teflon
Sodium Hydroxide, >30%, Boiling	D	A	B	A	C	B	A
Sodium Hydroxide, Molten	D	B	B	A	D	D	D
Sodium Hypochlorite (Still), 5%	D	C	C	C	C3	B3	A
Sodium Hyposulfite	D	B	A	A	B	A	A
Sodium Nitrate	B	A	B	A	B	A	A
Sodium Perborate	C	A	B	B	A	A	A
Sodium Peroxide	C	A	B	B	A	A	A
Sodium Phosphate, Tribasic	C	A	A	A	A	A	A
Sodium Silicate	B	A	B	B	A	A	A
Sodium Sulfate (All concentrations)	B	B	A	A	B	A	A
Sodium Sulfate, Hot	D	B	A	B	C	B	A
Sodium Sulfide, Saturated	B	A	B	A	B3	A	A
Sodium Sulfite, Hot	D	C	B	C	B	A	A
Sodium Thiosulfate	D	B	B	B	B	A	A
Stannic Chloride, <5%	D	D	B	B	D	D	A
Stannic Chloride, >5%	D	D	C	D	D	D	A
Stannic Chloride, SG 1.21, Boiling	D	D	D	D	D	D	A
Stannous Chloride, Saturated	D	B	B	B	D	B	A
Steam, 212°F	A	A	A	A	A	A	A
Steam, 600°F	C	A	A	A	A	A	D
Sulfite, Liquors	D	D	D	D	C	B	A
Sulfur, Molten, 266°F	B	A	A	A	B	A	A
Sulfur, Chloride	D	B	B	B	D	C	A
Sulfur Dioxide, 250°F, Dry	B	B	B	B	A	A	A
Sulfur Dioxide, Moist	D	D	D	D	B	A	A
Sulfuric Acid, <2%	D	B	B	B	C	B	A
Sulfuric Acid, 2 - 40%	D	B	B	B	D	D	A
Sulfuric Acid, 40%	D	B	B	B	D	D	A
Sulfuric Acid, Concentrated	B	B	D	D	B	B	A
Sulfuric Acid, <10%, Boiling	D	C	B	D	D	D	A
Sulfuric Acid, 10 - 80%, Boiling	D	D	C	D	D	D	A
Sulfuric Acid, Concentrated, Boiling	D	D	D	D	D	D	A
Sulfurous Acid, Saturated	D	D	D	D	B	B	A
Tannic Acid, 10%	D	B	A	A	A	A	A
Tar, Hot	B	A	B	B	A	A	A
Tartaric Acid, 120°F	D	A	A	A	B	A	A
Touline	A	A	A	A	A	A	A
Trichlorethylene	B	A	A	A	A	A	A
Turpentine	B	A	A	A	A	A	A
Varnish, Hot	C	A	A	A	A	A	A
Vegetable Oils	B	A	B	B	A	A	A
Vinegar	D	A	A	A	A	A	A
Water, Acid Mine	D	A	C	C	A3	A3	A
Water, Boiler Feed	B	A	A	A	A	A	A
Water, Distilled	D	A	A	A	A	A	A
Water, Salt Sea	D	B	A	C	C3	B3	A
Whiskey, Boiling	D	A	C	B	A	A	A
Wine	D	A	C	B	A	A	A
Xylene, Boiling	X	A	A	B	A	A	A
Zinc Chloride, 5%	D	B	B	B	C3	B3	A
Zinc Chloride, 5%, Boiling	D	D	B	C	D	D	A
Zinc Sulfate, Boiling	D	B	A	B	A	A	A

