

Technical Information

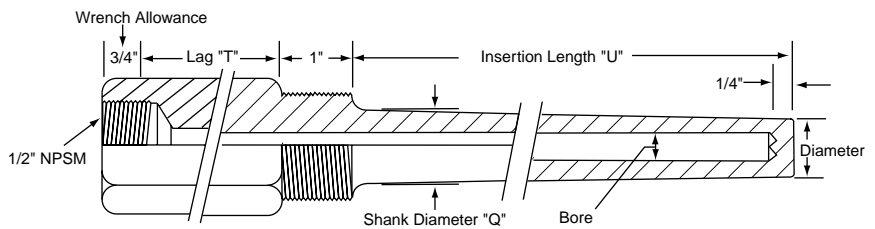
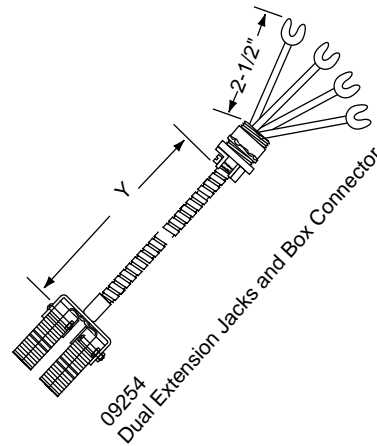
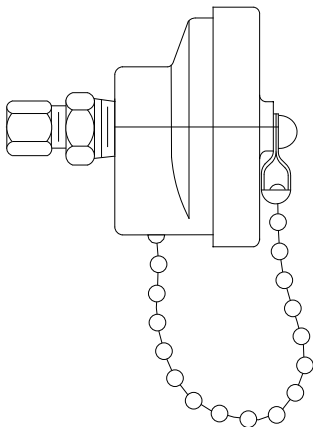
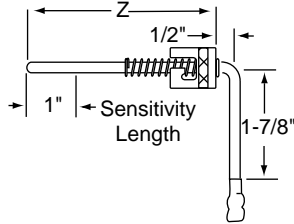
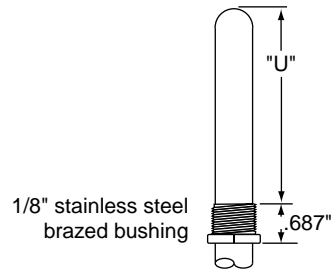
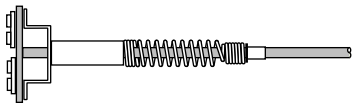
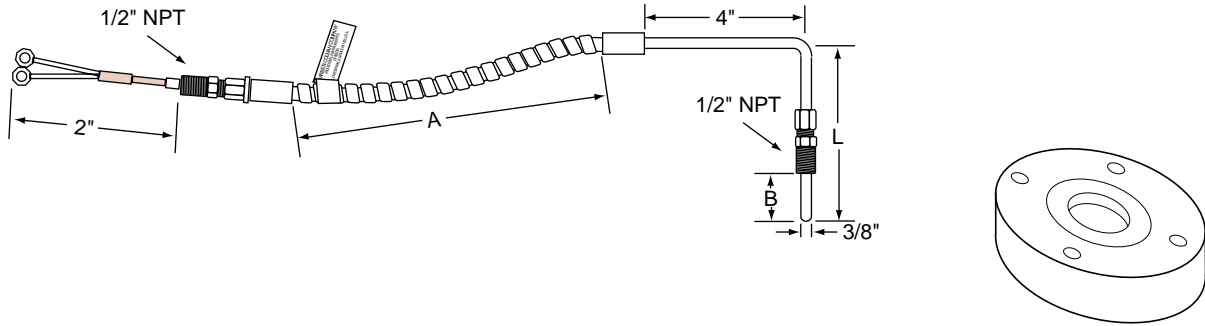

Technical Information

Technical Information

Identifying and Correcting Temperature Control Problems

Introduction

There are several methods of identifying and correcting temperature control problems without having special equipment or an electronics background. Usually visual indications provide clues of where the trouble may lie.

The first indication of trouble is usually when the process being controlled is either being overheated, not heating, or is alternately too hot, then too cold (wide temperature cycling).

In any of these cases, the problem may be due to the temperature sensing circuit, an indicator, or the controller.

In troubleshooting, the complete system must be considered. This includes the “thermocouple”, which senses the temperature, the “indicator” which indicates the temperature and compares it with a controller, the “instrument chassis” that amplifies the error signal (difference between the setpoint and the temperature indicated) and the “final control” device. The final control device may be a contactor, SCR power controller or an electric actuator.

Since the instrument is in the control system between the temperature sensing device or thermocouple and the final control device, it’s a good place to begin troubleshooting. Further, the indicator and pilot lights give a visual indication of events occurring in the control system, and may provide a clue to the exact location of the problem.

First, to eliminate the control instrument as the source of trouble, interchange it with another. If the trouble follows the instrument, the thermocouple or sensor and the final control device have been eliminated. If the trouble stays with the same zone or location, then the problem must exist outside the instrument.

The two most common sources of trouble in a typical control system are the thermocouple in the sensing portion and contactor in the control portion.

If the trouble did follow the instrument when it was interchanged with another, the instrument should be replaced with a spare and the faulty unit returned to the manufacturer for repair.

If the problem stayed at the location where it was first observed, the instrument should be observed for clues to the trouble. The indicator may be at room temperature, at control setpoint, above control point and, if observed for a time, the indicator may move up and down the scale erratically. This erratic motion may or may not be continuous. These observations can lead to a quick solution to the problem.

Troubleshooting

The following troubleshooting guide will assist in interpreting the clues furnished by the instrument, to locate problems in the temperature control system.

Corrective Action

Deteriorated Thermocouples

A deteriorated thermocouple will always cause a low reading. With base metal couples, evidence of deterioration is often visible at the hot junction. The metal may have a scaly, cracked appearance, usually accompanied by considerable discoloration or swelling. In some cases, the metal will be eroded, or partially eaten away. High temperature thermocouples of a noble metal (platinum) or the exotic type usually do not exhibit much visible

Technical Information

Corrective Action (continued)

evidence of deterioration (or contamination as it is sometimes called). However, platinum type thermocouples will sometimes have a frosty texture rather than a shiny surface on the wires of the element. The deteriorated couple must be replaced.

| Problem | Symptom | Possible Cause |
|---|---|--|
| Process Overheating | Temperature indicator showing above setpoint. Heat "on" light not lit. | <ul style="list-style-type: none"> • Contactor • Solenoid Valve • Power Controller • Reactor • Heating Element • Current to Position Converter • Motor Operator • Valve • Burner |
| | Temperature indicator showing above setpoint. Heat "on" light is lit. | <ul style="list-style-type: none"> • Temperature Controller |
| | Temperature indicator showing setpoint. Heat "on" light cycling on and off. | <ul style="list-style-type: none"> • Thermocouple and Leadwire • Temperature Controller |
| | Temperature indicator showing below setpoint. Heat "on" light is lit. | |
| Process Insufficiently Heating | Temperature indicator showing below setpoint. Heat "on" light is not lit. | <ul style="list-style-type: none"> • Temperature Controller |
| | Temperature indicator showing below setpoint. Heat "on" light is lit. | <ul style="list-style-type: none"> • Controller • Contactor • Solenoid Valve • Power Controller • Reactor • Heating Element • Current to Position Converter • Motor Operator • Valve • Burner |
| | Temperature indicator showing setpoint. Heat "on" light cycling on and off. | <ul style="list-style-type: none"> • Controller • Thermocouple and Leadwire |
| Process Control Temperature Wide Cycling | Temperature indicator showing setpoint. Heat "on" light cycling on and off. | <ul style="list-style-type: none"> • Thermocouple and Leadwire • Controller • Contactor • Solenoid Valve • Power Controller • Reactor • Heating Element • Current to Position Converter • Motor Operator • Valve • Burner |

Technical Information

Technical Information

Corrective Action (continued)

Deteriorated Protection Tube A protection tube may not exhibit visible damage, but porosity or very small holes may permit furnace atmospheres or molten metal to contaminate the thermocouple element inside. In the case of molten metal applications, the metal in the tube will be visible. In the case of atmospheric furnaces, should the thermocouple exhibit symptoms of swelling, color change (in the case of Type K couples) and crystallizing, the protection tube may be suspected of leaking. Both the protection tube and the thermocouple should be replaced.

Incorrect Thermocouple A thermocouple of a type other than that for which the instrument is calibrated will always cause an error. Use of the wrong type leadwire will also cause an error. The amount and direction of the error will depend on the particular combination of equipment under consideration (i.e., instrument calibration, type of thermocouple and type of leadwire). The type of thermocouple for which the instrument is calibrated is marked on the scale. Identification of the thermocouple and leadwire type is not quite so simple, but they can be identified by visual examination, testing with a magnet, or both. The foremost common base metal thermocouple pairs are: Iron/Constantan, Chromel/Alumel, Copper/Constantan and Chromel/Constantan. Except for Copper, the above metals have a silvery gray appearance when surface discolorations are scraped away. This makes visual identification difficult. However, Iron is strongly magnetic, Alumel somewhat less so, and Chromel and Constantan are not magnetic at all. Therefore, a magnet can be used as follows:

1. If the positive leg is magnetic, it is Iron/Constantan.
2. If the negative leg is magnetic, it is Chromel/Alumel.
3. If neither leg is magnetic, it is most likely another type.

Incorrect Leadwire The amount and direction of an error caused by incorrect leadwire depends on the particular combination of thermocouple and leadwire that is involved. Identification of leadwire type is usually easy since, in most cases, the I.S.A. Color Code, which is given below, will be used on the insulation.

Reversed Thermocouple Leadwire Connections

If the thermocouple leadwire connections are reversed at the thermocouple head or at the instrument, the instrument will indicate downscale when heat is applied to the thermocouple.

Any error caused by reverse connected (incorrectly polarized) leadwire will be on the low side. The amount of error may vary but it will always be a minus error. An indication that is higher than true temperature cannot be caused by incorrectly polarized leadwire.

Most leadwire is polarity color coded according to I.S.A. Standards. Regardless of the alloy type, these standards call for red insulation on a negative (-) conductor. Insulation color on the positive (+) conductor and the color of the overall sheath, if any, will vary with the type of wire. Since a few types of insulation do not lend themselves to color coding, or the original colors may have become indistinct, it is advisable not to depend entirely on the code for the determination of polarity.

If there is any doubt of polarity, use the following test:

- Step 1. Disconnect the leadwire from the thermocouple, leaving the opposite end connected to the instrument.
- Step 2. Twist the free ends of the wire together as if making a temporary splice.
- Step 3. Heat this junction for a moment with a match, soldering iron, or other source of heat and observe which way the instrument indicator moves. If it moves upscale, the connections at the thermocouple were correct and may be replaced as they were.

Technical Information

Corrective Action (continued)

If the terminal connections are correct, use the following test:

Step 1. Trace thermocouple leadwire back to the instrument. Check at junction boxes for splices.

Note: Leadwire reversals which cause low readings always exist in pairs. If one reversal connection is found, look for a second.

Step 2. When a splice is found, break it and repeat the procedures in steps 1, 2 and 3 above.

Step 3. Continue to work back to the instrument. Repeat the checks until all junctions or splices have been checked and reconnected in proper polarity.

Loose Connections

Check all terminal screws to insure that they are tight. Check wires for corrosion or any varnish and clean where necessary.

Short in Thermocouple or Leadwire

When a thermocouple or its leadwire is shorted, the short becomes the new hot junction, and the instrument will record the temperature at this point.

A short in the thermocouple is usually caused by broken ceramic insulator beads, metal in the protection tube or by broken thermocouple connection heads.

A short in the thermocouple leadwire may be caused by pinched wires where they are unprotected. Frayed insulation on leadwire may be an indication that a short is present.

A partially shorted thermocouple leadwire may be caused by moisture soaked leadwire insulation. Readings will always be low. Trouble is easily identified by disconnecting the instrument and the thermocouple from the leadwire and checking for leakage between the leadwires and the conductors with an ohmmeter. If leakage is found, the wire and the conduit in which it is installed must be checked to determine the cause. Moisture inside the conduit is one possibility when non-moisture proof leadwire insulation is used. Moisture in conduit may be present in applications where high humidity exists or where conduit is run underground. If this is the case, the leadwire should be replaced with wire having moisture resistant insulation, such as polyvinyl.

Two Grounds in a Thermocouple Circuit

A thermocouple may be grounded in one place. However, when a thermocouple is grounded at two different locations, the instrument will indicate an average temperature of these two locations.

A visual inspection should be made for bad insulation, broken terminal blocks or pinched wires. Make a continuity check after ungrounding the thermocouple to see if further grounds exist. If so, remove the ground or replace defective wire or thermocouple.

Wired to Wrong Terminals

Instruments with thermocouple break protection will read upscale and can never be made to coincide with the setpoint. This is also a symptom of an open in the thermocouple circuit.

A check of the wiring in the thermocouple circuit or a continuity check should determine where the open circuit exists.

Wired to Wrong Instrument

In new installations, the thermocouple wire may be wired to the wrong instrument. In this case, the control may be erratic or the control of one instrument may be overheating while another instrument on the same application will be considerably different and that zone may be cold.

The wiring should be traced or continuity checked to insure that the wiring is correct.

Technical Information

Corrective Action (continued)

Thermocouple Location

The thermocouple may not be touching the bottom of the protection tube. This will result in an air gap between the thermocouple and the protection tube and will tend to insulate it somewhat. Thermocouples should be checked to insure that they are not close to a heating element nor too remote from the load.

Care should be taken in relocating thermocouples that have been installed by an equipment manufacturer. The manufacturer may have a specific reason for placing the thermocouple in the installed location.

Stray Signal Pickup

The indicator may go upscale or downscale when power is turned on to the process. First, insure that this is not a TCB offset as may occur in millivoltmeter type instruments.

Check for, and remove, all grounds except those that may occur at the thermocouple hot junction. A check should be made to insure that the thermocouple leadwire is not run in the same conduit with power wiring. If possible, the source of the stray pickup should be isolated from the thermocouple and its leadwire.

If it is found that the stray pickup cannot be isolated from the thermocouple leadwire or thermocouple, a 2 mf capacitor may be used between the thermocouple, either plus or minus and ground. It may also be found necessary to place a 2 mf capacitor between plus and minus. These capacitors should be located at the instrument terminals.

In the case of d-c voltage pickup in the thermocouple or its leadwire, all grounds should be removed from the thermocouple circuit and then the thermocouple itself grounded to eliminate the effects of this d-c pickup.

Thermocouple Applications

Thermocouple Types

A thermocouple is a temperature sensor. In its most common form it consists of two wires of different composition. The two wires are joined together at two points which have different temperatures.

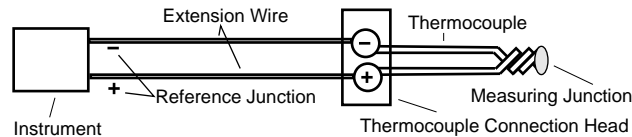

One of the points is at a known temperature. This point is the reference junction. The reference junction is also often, but less preferably, called the “cold” junction. The temperature of the reference junction is held constant, or its variation is electrically compensated for in the associated measuring instrumentation.

The second junction is the measuring junction. The measuring junction is also often, but less preferably, called the “hot” junction. The measuring junction is often at an unknown temperature requiring measurement, or at a temperature at which control is required.

A thermocouple is useful for temperature sensing because a measurable electrical signal is produced. The signal is a function of the difference in temperature between the measuring and reference junctions. Numerous combinations of dissimilar metals are used as thermocouples. Some of these combinations have become relatively standard and widely accepted for a large segment of industrial temperature measurements. A specific combination is generally referred to as a type, or calibration. Most of the common calibrations have American National Standards Institute (ANSI) letter codes. These letter codes were originally established by the Instrument Society of America.

The recommended temperature range for each type is that for which limits of error are established. No guarantee is made, or implied, regarding the successful use of any of the above calibrations in their recommended range. Use of a thermocouple outside its recommended temperature range may adversely affect its reliability over its recommended range.

Numerous factors combine to determine the successful application of a particular thermocouple. Some of these factors are temperature, cycling, chemical exposure, degree of protection provided, and mechanical abuse given to the thermocouple.

Thermocouple calibrations are maintained by proper manufacturing control of each of the thermoelements. Elemental constituents are controlled to a high degree. Homogeneity must be maintained, and all wire must be properly annealed.

Extension Wire

To reduce costs when long thermocouple lengths are required, especially with the noble metal calibrations, extension leadwire extends the reference junction of the thermocouple to the instrument. For the base metal calibrations the extension wire is nominally of the same composition as the thermocouple grade material. Control in manufacturing is not to the same degree as thermocouple grade wire. With lessening rigidity of manufacturing control considerable expense can be saved. There is a limitation on the maximum temperature to which the junction of extension wire and thermocouple wire should be exposed. For the base metal calibration except Type T the maximum temperature is 400°F (204°C). For type T it is 200°F (93°C).

Technical Information

Extension Wire (continued)

Noble metal types R, S, B, Platinel, the Tungsten-Rhenium calibrations are used with “compensating alternate” extension wire, which means the extension wire is made of material differing in composition from the thermocouple wire, but at temperatures encountered at the thermocouple extension junction, has corresponding temperature-EMF characteristics. The maximum temperature limitations for the thermocouple extension junction for calibration types R, S, B, and Platinel is 400°F (204°C). For Tungsten/Tungsten — 26% Rhenium (W/W — 26% Re), Tungsten — 3% Rhenium/Tungsten — 25% Rhenium (W — 3% Re/W - 25% Re) it is 500°F (260°C). For W- 5% Re/W- 26% Re it is 1600°F (871°C). The reason for the temperature limitation is that the thermocouple and extension wire junction is one of the materials of differing composition, and hence another thermocouple.

Whenever extension wire is used, precautions should be taken to insure a uniform temperature exists across both thermocouple and extension wire junctions. If there is sufficient temperature gradient between the temperature and extension wire junctions and the terminals at the instrument when copper extension wire is used, appreciable error may be produced.

Thermocouple extension wires should be installed in conduit whenever possible, and the conduit should be well grounded. Never run other electrical wires in the same conduit with extension wires. Keep the extension wires at least a foot away from any AC line.

Limits of Error

Mention has been made to “limits of error” applicable to thermocouple calibrations. Limits of error pertain to the temperature deviation tolerance acceptable for the calibration. Limits of error are stated either in degrees or as a percentage of the temperature measured. Limits of error of the extension wire for the Tungsten-Rhenium calibrations are presently given in millivolts. Two levels of limits of error are published for the common calibrations: standard and special. Special limits of error are generally one-half the magnitude of standard limits of error except for calibration Type E.

Limits of error are additive. For example, when a thermocouple-extension wire junction for Type J calibration exists, the standard limits of error for the thermocouple wire below 530°F (277°C) are $\pm 4^\circ\text{F}$ (2.2°C) and for the extension wire below 400°F are $\pm 4^\circ\text{F}$. Combined standard limits of error are $\pm 8^\circ\text{F}$ (4.4°C) and deviation from temperature-EMF tables for this combination within standard limits of error could be from 0 to Limits of error are only stated for common gauge sizes, and do not consider system errors.

Color Coding and Insulations

It is convenient to color code to identify the more common positive and negative legs of calibration. The negative thermoelement is identified by red, perhaps as a sleeving, paint, tag, or tracer in a layer of insulation.

Thermocouple and extension wire are available with either fibrous or plastic type insulation in “duplex construction.” The features of this construction are that the individual thermoelements are insulated and the pair of insulated thermoelements are combined under an outer layer of insulation. Color coding is often utilized with this method of insulating, and as follows:

Technical Information

Color Coding and Insulations (continued)

Insulation Color Codes

| <u>Calibration</u> | <u>Positive Thermo-element</u> | <u>Negative Thermo-element</u> | <u>Tracer* Duplex Thermo-couple Grade Wire</u> | <u>Outer Insulation Duplex Extension grade Wire</u> |
|--------------------|--------------------------------|--------------------------------|--|---|
| J, JX | White | Red | Black | Black |
| K, KX | Yellow | Red | Yellow | Yellow |
| T, TX | Blue | Red | Blue | Blue |
| E, EX | Purple | Red | Purple | Purple |
| RS, SX | Black | Red | – | Green |

*Where insulation type permits, the outer insulation layer for thermocouple grade wire is brown, the tracer is threaded through the outer layer.

All of the information related so far has been concerned with the thermoelements and their characteristics. In the normal usage of a thermocouple the thermoelements must be protected from various environments that are detrimental to the materials comprising them. Effects of attack from the environment, temperature cycling, and aging all work toward producing errors from a thermocouple.

In addition to the environmental protection required, the thermoelements must be electrically insulated from one another at all points except the measuring junction.

Electrical insulation is accomplished by various dielectric materials such as varnish, plastic, inorganic fibers, and ceramic. General temperature ratings for these insulation materials are:

Temperature Ratings for Insulation

| <u>General Insulation Type</u> | <u>General Maximum Temperature Rating °F</u> |
|--------------------------------|--|
| Kapton | + 700 |
| Nylon | + 350 |
| Teflon | + 400 |
| PVC | + 210 |
| Fiberglass | + 900 |
| Ceramic-Cordierite or Mullite | + 1800 |
| Ceramic-Alumina | + 3000 |
| Compacted Magnesia (MgO) | + 2500 |

The plastic type insulations provide protection to the thermoelements from moisture or fluid contamination. They have relatively lower temperature applications compared to the inorganic fiber types. The inorganic fiber types of insulation often are furnished with moisture proofing impregnations which are burned off with exposure above 400 to 500°F. Hard fired ceramic insulators are used on both base metal and noble metal calibrations. Above 2400°F alumina insulators are recommended for the noble metal calibrations. Beryllia and thoria insulators can be used with proper precautions to 4000 to 4200°F.

If wire insulation degrades to the degree that electrical contact of the two thermoelements is at a point other than the measuring junction, the signal produced by the thermocouple will be one based on the temperature difference between the reference junction and the new junction which is a secondary junction.

Technical Information

Protection Tubes

Additional protection of the thermoelements is often required. Numerous materials are available for the protection of a thermocouple in various industrial applications. A table listing the more readily available thermocouple protection tube materials and application data is presented in the Industrial Sensors section of this document. Data of this nature is at best only usable as a general guide. This information cannot be taken as a guarantee of adequate or successful use of any of the listed materials in any specific application because of numerous variables possible such as impurities, concentration, temperature cycling, vibration, etc.

General Considerations

Numerous other materials are available that provide protection for a thermocouple. Factors such as machinability, ductility, and cost determine the availability of any of the listed materials in protection tube form. Some of these materials are available in a restricted number of tubing or pipe sizes. Others are readily available in many sizes. As mentioned earlier, the reference to a usable maximum temperature in no way insures satisfactory usage of a material in a specific application to that temperature.

In addition to the many considerations relating to calibration and protection tube material choice, a thermocouple must be located properly with respect to a work load and energy source being controlled whenever the thermocouple is used with controlling instrumentation. Considerations to keep in mind are the minimization of flow disruption caused by the sensor if it protrudes into a stream of liquid or gas; insertion into the medium being measured, either a fluid or a solid, to a sufficient depth to enable the measuring junction to respond to temperature changes of this medium rather than having it swamped by a temperature of a surrounding medium; and, under some conditions, awareness of heat flow into or out of the measuring junction due to the heat conductivity of the thermoelements and protecting materials.

In most industrial applications errors from heat flow through the sensor are negligible; but insertion depth, power source, sensor and work load placement are factors readily controllable at the system design stage. A "rule of thumb": minimum immersion of the sensor into the fluid or medium measured should be 4 to 10 times the OD of the protection tube.

Thermocouple assemblies provided with protection tubes are available with three types of junction styles: grounded, ungrounded (isolated), and exposed.

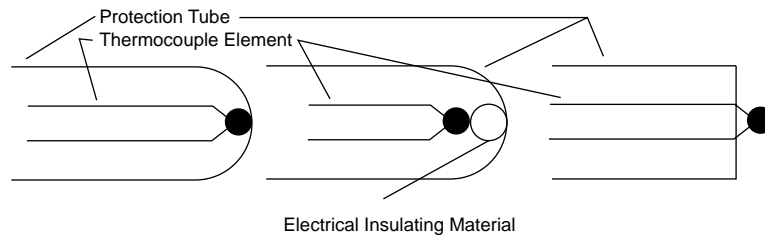

The grounded junction is most common. This style is available on assemblies having electrically conductive protection tubes, and means the thermocouple measuring junction is in electrical contact with the protection tube. In the ungrounded junction steps are taken in manufacture to electrically isolate the measuring junction from an electrically conductive protection tube. This junction style is required when the thermocouple is used with instrumentation which is itself not internally electrically isolated. The ungrounded style junction is slower to respond than the grounded style for a given junction end mass, but it can be the most reliable and rugged style junction. The exposed junction is where the measuring junction of the thermocouple is not protected by any material. It is the fastest responding junction, but most subject to corrosive failure.

Technical Information

Protection Tubes (continued)

Pipe vs Tube Sizes

Pipe dimensions of 12 inches and smaller have outside diameters numerically larger than the corresponding nominal sizes, whereas outside diameters of tubes are identical to nominal sizes. Pipe is identified by its nominal size. The manufacture of pipe in the nominal sizes of 1/8" to 12", inclusive, is based on a standardized outside diameter.

Wall Thickness

Wall thickness designations of "standard," "extra strong," and "double extra strong" have been commercially used for years. Schedule numbers were subsequently added as a convenient designation for ordering pipe. Standard and Schedule 40 are identical for nominal pipe sizes up to 10", inclusive. Larger standard sizes have 3/8" wall thickness.

Extra strong and Schedule 80 are identical for nominal pipe sizes up to 8", inclusive. Larger sizes of extra strong have 1/2" wall thickness.

| <u>Nominal</u> | <u>O.D.</u> | <u>Wall Thickness</u> | |
|----------------|-------------|-----------------------|-----------|
| | | <u>40</u> | <u>80</u> |
| 1/4" | 0.540" | 0.088" | 0.119" |
| 1/2" | 0.840" | 0.109" | 0.147" |
| 3/4" | 1.050" | 0.113" | 0.154" |
| 1" | 1.315" | 0.133" | 0.179" |

Technical Information

Differential Temperature (ΔT) Measurement with Thermocouples

Introduction

Thermocouples are often used for differential temperature (ΔT) measurement in industrial processes where the differential is of a span sufficient to generate the required signal for the associated instrumentation. Thermocouples provide a possible advantage over other sensor types where small size and ease of interchangeability are important.

Linearity

The output of a given span is not linear for the common thermocouple calibrations. See Table 1. When the process requires ΔT measurement over only a restricted range of working temperatures, the non-linearity may not be significant. The combined limits of error in degrees for two thermocouples in ΔT measurement is equal to the square root of the sum of the squares of the individual thermocouple limits of error. For J and K calibrations, and standard limits of error for thermocouples below 530°F, the combined thermocouple error is $\pm\sqrt{(4)^2+(4)^2} = \pm 5.640^\circ\text{F}$. See Table 2. Intermediate connections should be minimized in the ΔT thermocouple circuit to lessen the introduction of parasitic EMF's and the reduction of accuracy that can result. One, or both, of the thermocouples should be ungrounded.

Wiring

Schematic Wiring for ΔT with Thermocouples

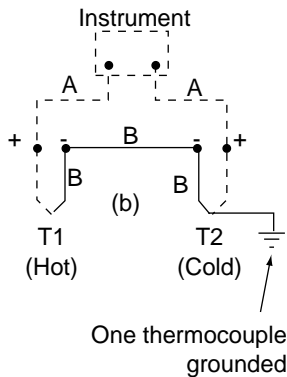
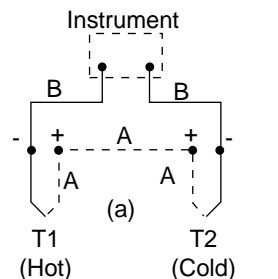

Thermocouple Wire:
 A (Positive) -----
 B (Negative) _____

When two thermocouples are connected for ΔT measurement either the positive or negative legs of the thermocouples are connected together, with the remaining legs connected to the instrument. There is a reversal in polarity of the differential temperature signal when the thermocouple junctions change relationship regarding the "hot" and "cold" designations. If a zero-centered span is not available on the associated instrument, then provisions must be made to reverse polarity at the instrument. Reference junction compensation is not utilized for the individual thermocouples when they are connected for ΔT measurement.

A ΔT measurement is not absolute and, as such, will not give an indication of undesirable over-temperature condition in a process. For safety considerations, an absolute temperature measurement and/or indication may be necessary when measuring a ΔT condition. In any temperature measurement, attention should be provided to selection of sensors sufficiently rugged for the environment of the process, location of the sensors, and installation details.

Table 1. Output (mV) for a 10°F Span at Various Temperatures for Common Calibrations

| Calibration | Temperature Span | | | | | |
|-------------|------------------|--------------|--------------|--------------|--------------|----------------|
| | -110 to -100°F | 110 to 100°F | 300 to 310°F | 500 to 510°F | 700 to 710°F | 1000 to 1010°F |
| J | 0.245 | 0.291 | 0.306 | 0.308 | 0.306 | 0.316 |
| K | 0.184 | 0.228 | 0.224 | 0.227 | 0.234 | 0.237 |
| T | 0.172 | 0.234 | 0.279 | 0.313 | 0.339 | — |
| E | 0.272 | 0.346 | 0.395 | 0.426 | 0.442 | 0.449 |

Table 2. Output (mV) for a 30°F Span at Various Temperatures for Common Calibrations

| Calibration | Temperature Span | | | | | |
|-------------|------------------|--------------|--------------|--------------|--------------|----------------|
| | -130 to -100°F | 100 to 130°F | 300 to 330°F | 500 to 530°F | 700 to 730°F | 1000 to 1030°F |
| J | 0.723 | 0.878 | 0.920 | 0.924 | 0.919 | 0.949 |
| K | 0.543 | 0.686 | 0.669 | 0.683 | 0.702 | 0.710 |
| T | 0.508 | 0.708 | 0.843 | 1.044 | 1.021 | — |
| E | 0.801 | 1.048 | 1.293 | 1.281 | 1.329 | 1.348 |

REFERENCE R.B. Crawford, "Industrial Applications of Temperature Difference Measurements— Temperature, Its Measurement and Control in Science and Industry" (Reinhold Publishing Corporation, New York, 1962. Volume 3, Part 2, PP. 91 3-925.

Type B Platinum-6% Rhodium vs Platinum-30% Rhodium ITS-90

Type E

Chromel vs. Constantan ITS-90

| °C | 0 | 10 | 20 | 30 | 40 | 50 | 60 | 70 | 80 | 90 | 100 |
|------|--------|--------|--------|--------|--------|--------|--------|--------|--------|--------|--------|
| 0 | 0.000 | -0.002 | -0.003 | -0.002 | 0.000 | 0.002 | 0.006 | 0.011 | 0.017 | 0.025 | 0.033 |
| 100 | 0.033 | 0.043 | 0.053 | 0.065 | 0.078 | 0.092 | 0.107 | 0.123 | 0.141 | 0.159 | 0.178 |
| 200 | 0.178 | 0.199 | 0.220 | 0.243 | 0.267 | 0.291 | 0.317 | 0.344 | 0.372 | 0.401 | 0.431 |
| 300 | 0.431 | 0.462 | 0.494 | 0.527 | 0.561 | 0.596 | 0.632 | 0.669 | 0.707 | 0.746 | 0.787 |
| 400 | 0.787 | 0.828 | 0.870 | 0.913 | 0.957 | 1.002 | 1.048 | 1.095 | 1.143 | 1.192 | 1.242 |
| 500 | 1.242 | 1.293 | 1.344 | 1.397 | 1.451 | 1.505 | 1.561 | 1.617 | 1.675 | 1.733 | 1.792 |
| 600 | 1.792 | 1.852 | 1.913 | 1.975 | 2.037 | 2.101 | 2.165 | 2.230 | 2.296 | 2.363 | 2.431 |
| 700 | 2.431 | 2.499 | 2.569 | 2.639 | 2.710 | 2.782 | 2.854 | 2.928 | 3.002 | 3.078 | 3.154 |
| 800 | 3.154 | 3.230 | 3.308 | 3.386 | 3.466 | 3.546 | 3.626 | 3.708 | 3.790 | 3.873 | 3.957 |
| 900 | 3.957 | 4.041 | 4.127 | 4.213 | 4.299 | 4.387 | 4.475 | 4.564 | 4.653 | 4.743 | 4.834 |
| 1000 | 4.834 | 4.926 | 5.018 | 5.111 | 5.205 | 5.299 | 5.394 | 5.489 | 5.585 | 5.682 | 5.780 |
| 1100 | 5.780 | 5.878 | 5.976 | 6.075 | 6.175 | 6.276 | 6.377 | 6.478 | 6.580 | 6.683 | 6.786 |
| 1200 | 6.786 | 6.890 | 6.995 | 7.100 | 7.205 | 7.311 | 7.417 | 7.524 | 7.632 | 7.740 | 7.848 |
| 1300 | 7.848 | 7.957 | 8.066 | 8.176 | 8.286 | 8.397 | 8.508 | 8.620 | 8.731 | 8.844 | 8.956 |
| 1400 | 8.956 | 9.069 | 9.182 | 9.296 | 9.410 | 9.524 | 9.639 | 9.753 | 9.868 | 9.984 | 10.099 |
| 1500 | 10.099 | 10.215 | 10.331 | 10.447 | 10.563 | 10.679 | 10.796 | 10.913 | 11.029 | 11.146 | 11.263 |
| 1600 | 11.263 | 11.380 | 11.497 | 11.614 | 11.731 | 11.848 | 11.965 | 12.082 | 12.199 | 12.316 | 12.433 |
| 1700 | 12.433 | 12.549 | 12.666 | 12.782 | 12.898 | 13.014 | 13.130 | 13.246 | 13.361 | 13.476 | 13.591 |
| 1800 | 13.591 | 13.706 | 13.820 | | | | | | | | |

| °C | 0 | -10 | -20 | -30 | -40 | -50 | -60 | -70 | -80 | -90 | -100 |
|------|--------|--------|--------|--------|--------|--------|--------|--------|--------|--------|--------|
| -200 | -8.825 | -9.063 | -9.274 | -9.455 | -9.604 | -9.718 | -9.797 | -9.835 | | | |
| -100 | -5.237 | -5.681 | -6.107 | -6.516 | -6.907 | -7.279 | -7.632 | -7.963 | -8.273 | -8.561 | -8.825 |
| 0 | 0.000 | -0.582 | -1.152 | -1.709 | -2.255 | -2.787 | -3.306 | -3.811 | -4.302 | -4.777 | -5.237 |

| °C | 0 | 10 | 20 | 30 | 40 | 50 | 60 | 70 | 80 | 90 | 100 |
|-----|--------|--------|--------|--------|--------|--------|--------|--------|--------|--------|--------|
| 0 | 0.000 | 0.591 | 1.192 | 1.801 | 2.420 | 3.048 | 3.685 | 4.330 | 4.985 | 5.648 | 6.319 |
| 100 | 6.319 | 6.998 | 7.685 | 8.379 | 9.081 | 9.789 | 10.503 | 11.224 | 11.951 | 12.684 | 13.421 |
| 200 | 13.421 | 14.164 | 14.912 | 15.664 | 16.420 | 17.181 | 17.945 | 18.713 | 19.484 | 20.259 | 21.036 |
| 300 | 21.036 | 21.817 | 22.600 | 23.386 | 24.174 | 24.964 | 25.757 | 26.552 | 27.348 | 28.146 | 28.946 |
| 400 | 28.946 | 29.747 | 30.550 | 31.354 | 32.159 | 32.965 | 33.772 | 34.579 | 35.387 | 36.196 | 37.005 |
| 500 | 37.005 | 37.815 | 38.624 | 39.434 | 40.243 | 41.053 | 41.862 | 42.671 | 43.479 | 44.286 | 45.093 |
| 600 | 45.093 | 45.900 | 46.705 | 47.509 | 48.313 | 49.116 | 49.917 | 50.718 | 51.517 | 52.315 | 53.112 |
| 700 | 53.112 | 53.908 | 54.703 | 55.497 | 56.289 | 57.080 | 57.870 | 58.659 | 59.446 | 60.232 | 61.017 |
| 800 | 61.017 | 61.801 | 62.583 | 63.364 | 64.144 | 64.922 | 65.698 | 66.473 | 67.246 | 68.017 | 68.787 |
| 900 | 68.787 | 69.554 | 70.319 | 71.082 | 71.844 | 72.603 | 73.360 | 74.115 | 74.869 | 75.621 | 76.373 |

| °F | 0 | -10 | -20 | -30 | -40 | -50 | -60 | -70 | -80 | -90 | -100 |
|------|--------|--------|--------|--------|--------|--------|--------|--------|--------|--------|--------|
| -400 | -9.604 | -9.672 | -9.729 | -9.775 | -9.809 | -9.830 | | | | | |
| -300 | -8.404 | -8.561 | -8.710 | -8.852 | -8.986 | -9.112 | -9.229 | -9.338 | -9.436 | -9.525 | -9.604 |
| -200 | -6.472 | -6.692 | -6.907 | -7.116 | -7.319 | -7.516 | -7.707 | -7.891 | -8.069 | -8.240 | -8.404 |
| -100 | -3.976 | -4.248 | -4.515 | -4.777 | -5.035 | -5.287 | -5.535 | -5.777 | -6.014 | -6.246 | -6.472 |
| 0 | -1.026 | -1.339 | -1.648 | -1.953 | -2.255 | -2.552 | -2.846 | -3.135 | -3.420 | -3.700 | -3.976 |

| °F | 0 | 10 | 20 | 30 | 40 | 50 | 60 | 70 | 80 | 90 | 100 |
|------|--------|--------|--------|--------|--------|--------|--------|--------|--------|--------|--------|
| 0 | | | | 0.000 | -0.001 | -0.002 | -0.002 | -0.003 | -0.002 | -0.002 | -0.001 |
| 100 | -0.001 | 0.000 | 0.002 | 0.004 | 0.006 | 0.009 | 0.012 | 0.015 | 0.019 | 0.023 | 0.027 |
| 200 | 0.027 | 0.032 | 0.037 | 0.043 | 0.049 | 0.055 | 0.061 | 0.068 | 0.075 | 0.083 | 0.090 |
| 300 | 0.090 | 0.099 | 0.107 | 0.116 | 0.125 | 0.135 | 0.145 | 0.155 | 0.165 | 0.176 | 0.187 |
| 400 | 0.187 | 0.199 | 0.211 | 0.223 | 0.235 | 0.248 | 0.261 | 0.275 | 0.288 | 0.303 | 0.317 |
| 500 | 0.317 | 0.332 | 0.347 | 0.362 | 0.378 | 0.394 | 0.411 | 0.427 | 0.444 | 0.462 | 0.479 |
| 600 | 0.479 | 0.497 | 0.516 | 0.534 | 0.553 | 0.572 | 0.592 | 0.612 | 0.632 | 0.653 | 0.673 |
| 700 | 0.673 | 0.694 | 0.716 | 0.738 | 0.760 | 0.782 | 0.805 | 0.828 | 0.851 | 0.875 | 0.898 |
| 800 | 0.898 | 0.923 | 0.947 | 0.972 | 0.997 | 1.022 | 1.048 | 1.074 | 1.100 | 1.127 | 1.154 |
| 900 | 1.154 | 1.181 | 1.208 | 1.236 | 1.264 | 1.293 | 1.321 | 1.350 | 1.379 | 1.409 | 1.439 |
| 1000 | 1.439 | 1.469 | 1.499 | 1.530 | 1.561 | 1.592 | 1.624 | 1.655 | 1.687 | 1.720 | 1.752 |
| 1100 | 1.752 | 1.785 | 1.818 | 1.852 | 1.886 | 1.920 | 1.954 | 1.988 | 2.023 | 2.058 | 2.094 |
| 1200 | 2.094 | 2.129 | 2.165 | 2.201 | 2.237 | 2.274 | 2.311 | 2.348 | 2.385 | 2.423 | 2.461 |
| 1300 | 2.461 | 2.499 | 2.538 | 2.576 | 2.615 | 2.654 | 2.694 | 2.734 | 2.774 | 2.814 | 2.854 |
| 1400 | 2.854 | 2.895 | 2.936 | 2.978 | 3.019 | 3.061 | 3.103 | 3.145 | 3.188 | 3.230 | 3.273 |
| 1500 | 3.273 | 3.317 | 3.360 | 3.404 | 3.448 | 3.492 | 3.537 | 3.581 | 3.626 | 3.672 | 3.717 |
| 1600 | 3.717 | 3.763 | 3.809 | 3.855 | 3.901 | 3.948 | 3.994 | 4.041 | 4.089 | 4.136 | 4.184 |
| 1700 | 4.184 | 4.232 | 4.280 | 4.328 | 4.377 | 4.426 | 4.475 | 4.524 | 4.574 | 4.623 | 4.673 |
| 1800 | 4.673 | 4.723 | 4.774 | 4.824 | 4.875 | 4.926 | 4.977 | 5.028 | 5.080 | 5.132 | 5.184 |
| 1900 | 5.184 | 5.236 | 5.288 | 5.341 | 5.394 | 5.447 | 5.500 | 5.553 | 5.607 | 5.661 | 5.715 |
| 2000 | 5.715 | 5.769 | 5.823 | 5.878 | 5.932 | 5.987 | 6.042 | 6.098 | 6.153 | 6.209 | 6.264 |
| 2100 | 6.264 | 6.320 | 6.377 | 6.433 | 6.490 | 6.546 | 6.603 | 6.660 | 6.718 | 6.775 | 6.833 |
| 2200 | 6.833 | 6.890 | 6.948 | 7.006 | 7.065 | 7.123 | 7.182 | 7.240 | 7.299 | 7.358 | 7.417 |
| 2300 | 7.417 | 7.477 | 7.536 | 7.596 | 7.656 | 7.716 | 7.776 | 7.836 | 7.897 | 7.957 | 8.018 |
| 2400 | 8.018 | 8.079 | 8.140 | 8.201 | 8.262 | 8.323 | 8.385 | 8.446 | 8.508 | 8.570 | 8.632 |
| 2500 | 8.632 | 8.694 | 8.756 | 8.819 | 8.881 | 8.944 | 9.006 | 9.069 | 9.132 | 9.195 | 9.258 |
| 2600 | 9.258 | 9.321 | 9.385 | 9.448 | 9.511 | 9.575 | 9.639 | 9.702 | 9.766 | 9.830 | 9.894 |
| 2700 | 9.894 | 9.958 | 10.022 | 10.086 | 10.150 | 10.215 | 10.279 | 10.344 | 10.408 | 10.473 | 10.537 |
| 2800 | 10.537 | 10.602 | 10.666 | 10.731 | 10.796 | 10.861 | 10.925 | 10.990 | 11.055 | 11.120 | 11.185 |
| 2900 | 11.185 | 11.250 | 11.315 | 11.380 | 11.445 | 11.510 | 11.575 | 11.640 | 11.705 | 11.770 | 11.835 |
| 3000 | 11.835 | 11.900 | 11.965 | 12.030 | 12.095 | 12.160 | 12.225 | 12.290 | 12.355 | 12.420 | 12.484 |
| 3100 | 12.484 | 12.549 | 12.614 | 12.679 | 12.743 | 12.808 | 12.872 | 12.937 | 13.001 | 13.066 | 13.130 |
| 3200 | 13.130 | 13.194 | 13.259 | 13.323 | 13.387 | 13.451 | 13.515 | 13.579 | 13.642 | 13.706 | 13.769 |

| °F | 0 | 10 | 20 | 30 | 40 | 50 | 60 | 70 | 80 | 90 | 100 |
|------|--------|--------|--------|--------|--------|--------|--------|--------|--------|--------|--------|
| 0 | -1.026 | -0.709 | -0.389 | -0.065 | 0.262 | 0.591 | 0.924 | 1.259 | 1.597 | 1.938 | 2.281 |
| 100 | 2.281 | 2.628 | 2.977 | 3.330 | 3.685 | 4.042 | 4.403 | 4.766 | 5.131 | 5.500 | 5.871 |
| 200 | 5.871 | 6.244 | 6.620 | 6.998 | 7.379 | 7.762 | 8.147 | 8.535 | 8.924 | 9.316 | 9.710 |
| 300 | 9.710 | 10.106 | 10.503 | 10.903 | 11.305 | 11.708 | 12.113 | 12.520 | 12.929 | 13.339 | 13.751 |
| 400 | 13.751 | 14.164 | 14.579 | 14.995 | 15.413 | 15.831 | 16.252 | 16.673 | 17.096 | 17.520 | 17.945 |
| 500 | 17.945 | 18.371 | 18.798 | 19.227 | 19.656 | 20.086 | 20.517 | 20.950 | 21.383 | 21.817 | 22.252 |
| 600 | 22.252 | 22.687 | 23.124 | 23.561 | 23.999 | 24.437 | 24.876 | 25.316 | 25.757 | 26.198 | 26.640 |
| 700 | 26.640 | 27.082 | 27.525 | 27.969 | 28.413 | 28.857 | 29.302 | 29.747 | 30.193 | 30.639 | 31.086 |
| 800 | 31.086 | 31.533 | 31.980 | 32.427 | 32.875 | 33.323 | 33.772 | 34.220 | 34.669 | 35.118 | 35.567 |
| 900 | 35.567 | 36.016 | 36.466 | 36.915 | 37.365 | 37.815 | 38.265 | 38.714 | 39.164 | 39.614 | 40.064 |
| 1000 | 40.064 | 40.513 | 40.963 | 41.412 | 41.862 | 42.311 | 42.760 | 43.209 | 43.658 | 44.107 | 44.555 |
| 1100 | 44.555 | 45.004 | 45.452 | 45.900 | 46.347 | 46.794 | 47.241 | 47.688 | 48.135 | 48.581 | 49.027 |
| 1200 | 49.027 | 49.472 | 49.917 | 50.362 | 50.807 | 51.251 | 51.695 | 52.138 | 52.581 | 53.024 | 53.466 |
| 1300 | 53.466 | 53.908 | 54.350 | 54.791 | 55.232 | 55.673 | 56.113 | 56.553 | 56.992 | 57.431 | 57.870 |
| 1400 | 57.870 | 58.308 | 58.746 | 59.184 | 59.621 | 60.058 | 60.494 | 60.930 | 61.366 | 61.801 | 62.236 |
| 1500 | 62.236 | 62.670 | 63.104 | 63.538 | 63.971 | 64.403 | 64.835 | 65.267 | 65.698 | 66.129 | 66.559 |
| 1600 | 66.559 | 66.989 | 67.418 | 67.846 | 68.274 | 68.701 | 69.128 | 69.554 | 69.979 | 70.404 | 70.828 |
| 1700 | 70.828 | 71.252 | 71.675 | 72.097 | 72.518 | 72.939 | 73.360 | 73.780 | 74.199 | 74.618 | 75.036 |

Type C Tungsten- 5% Rhenium vs Tungsten-26% Rhenium ITS-90

| °C | 0 | 10 | 20 | 30 | 40 | 50 | 60 | 70 | 80 | 90 | 100 |
|------|--------|--------|--------|--------|--------|--------|--------|--------|--------|--------|--------|
| 0 | 0.000 | 0.135 | 0.273 | 0.413 | 0.555 | 0.699 | 0.846 | 0.994 | 1.145 | 1.297 | 1.451 |
| 100 | 1.451 | 1.608 | 1.766 | 1.926 | 2.087 | 2.251 | 2.415 | 2.582 | 2.750 | 2.919 | 3.090 |
| 200 | 3.090 | 3.262 | 3.436 | 3.610 | 3.786 | 3.963 | 4.141 | 4.321 | 4.501 | 4.682 | 4.865 |
| 300 | 4.865 | 5.048 | 5.232 | 5.417 | 5.603 | 5.789 | 5.976 | 6.164 | 6.353 | 6.542 | 6.732 |
| 400 | 6.732 | 6.922 | 7.113 | 7.305 | 7.497 | 7.689 | 7.882 | 8.075 | 8.269 | 8.463 | 8.657 |
| 500 | 8.657 | 8.851 | 9.046 | 9.241 | 9.436 | 9.631 | 9.827 | 10.022 | 10.218 | 10.413 | 10.609 |
| 600 | 10.609 | 10.804 | 10.999 | 11.195 | 11.390 | 11.585 | 11.780 | 11.974 | 12.169 | 12.364 | 12.559 |
| 700 | 12.559 | 12.753 | 12.947 | 13.141 | 13.335 | 13.529 | 13.723 | 13.916 | 14.109 | 14.301 | 14.494 |
| 800 | 14.494 | 14.686 | 14.878 | 15.069 | 15.260 | 15.451 | 15.641 | 15.831 | 16.021 | 16.210 | 16.398 |
| 900 | 16.398 | 16.587 | 16.775 | 16.962 | 17.149 | 17.335 | 17.521 | 17.707 | 17.892 | 18.076 | 18.260 |
| 1000 | 18.260 | 18.444 | 18.627 | 18.809 | 18.991 | 19.172 | 19.353 | 19.533 | 19.713 | 19.892 | 20.071 |
| 1100 | 20.071 | 20.249 | 20.426 | 20.603 | 20.779 | 20.955 | 21.130 | 21.305 | 21.479 | 21.652 | 21.825 |
| 1200 | 21.825 | 21.997 | 22.169 | 22.340 | 22.510 | 22.680 | 22.849 | 23.018 | 23.186 | 23.353 | 23.520 |
| 1300 | 23.520 | 23.686 | 23.852 | 24.017 | 24.181 | 24.345 | 24.508 | 24.671 | 24.833 | 24.994 | 25.155 |
| 1400 | 25.155 | 25.315 | 25.475 | 25.633 | 25.792 | 25.949 | 26.107 | 26.263 | 26.419 | 26.574 | 26.729 |
| 1500 | 26.729 | 26.883 | 27.037 | 27.190 | 27.342 | 27.493 | 27.645 | 27.795 | 27.945 | 28.094 | 28.243 |
| 1600 | 28.243 | 28.391 | 28.538 | 28.685 | 28.831 | 28.977 | 29.122 | 29.266 | 29.410 | 29.553 | 29.696 |
| 1700 | 29.696 | 29.838 | 29.979 | 30.120 | 30.260 | 30.399 | 30.538 | 30.676 | 30.813 | 30.950 | 31.087 |
| 1800 | 31.087 | 31.222 | 31.357 | 31.491 | 31.625 | 31.758 | 31.890 | 32.022 | 32.153 | 32.283 | 32.413 |
| 1900 | 32.413 | 32.542 | 32.670 | 32.797 | 32.924 | 33.050 | 33.175 | 33.300 | 33.424 | 33.547 | 33.669 |
| 2000 | 33.669 | 33.791 | 33.911 | 34.031 | 34.151 | 34.269 | 34.387 | 34.503 | 34.619 | 34.734 | 34.849 |
| 2100 | 34.849 | 34.962 | 35.074 | 35.186 | 35.296 | 35.406 | 35.515 | 35.623 | 35.730 | 35.836 | 35.940 |
| 2200 | 35.940 | 36.044 | 36.147 | 36.249 | 36.350 | 36.449 | 36.548 | 36.645 | 36.742 | 36.837 | 36.931 |
| 2300 | 36.931 | 37.024 | | | | | | | | | |

Type C Tungsten- 5% Rhenium vs Tungsten-26% Rhenium ITS-90

| °F | 0 | 10 | 20 | 30 | 40 | 50 | 60 | 70 | 80 | 90 | 100 |
|------|--------|--------|--------|--------|--------|--------|--------|--------|--------|--------|--------|
| 0 | 0.523 | 0.603 | 0.683 | 0.764 | 0.846 | 0.928 | 1.011 | 1.094 | 1.178 | 1.263 | 1.348 |
| 100 | 1.348 | 1.434 | 1.521 | 1.608 | 1.695 | 1.784 | 1.872 | 1.962 | 2.051 | 2.142 | 2.232 |
| 200 | 2.232 | 2.324 | 2.415 | 2.508 | 2.600 | 2.694 | 2.787 | 2.881 | 2.976 | 3.071 | 3.166 |
| 300 | 3.166 | 3.262 | 3.358 | 3.455 | 3.552 | 3.649 | 3.747 | 3.845 | 3.943 | 4.042 | 4.141 |
| 400 | 4.141 | 4.241 | 4.341 | 4.441 | 4.541 | 4.642 | 4.743 | 4.844 | 4.946 | 5.048 | 5.150 |
| 500 | 5.150 | 5.252 | 5.355 | 5.458 | 5.620 | 5.721 | 5.822 | 5.924 | 6.026 | 6.128 | 6.231 |
| 600 | 6.185 | 6.290 | 6.395 | 6.500 | 6.605 | 6.711 | 6.817 | 6.922 | 7.028 | 7.135 | 7.241 |
| 700 | 7.241 | 7.347 | 7.454 | 7.561 | 7.668 | 7.775 | 7.882 | 7.989 | 8.097 | 8.204 | 8.312 |
| 800 | 8.312 | 8.420 | 8.527 | 8.635 | 8.743 | 8.851 | 8.960 | 9.068 | 9.176 | 9.284 | 9.393 |
| 900 | 9.393 | 9.501 | 9.610 | 9.718 | 9.827 | 9.935 | 10.044 | 10.153 | 10.261 | 10.370 | 10.478 |
| 1000 | 10.478 | 10.587 | 10.696 | 10.804 | 10.913 | 11.021 | 11.130 | 11.238 | 11.346 | 11.455 | 11.563 |
| 1100 | 11.563 | 11.671 | 11.780 | 11.888 | 11.996 | 12.104 | 12.213 | 12.321 | 12.429 | 12.537 | 12.645 |
| 1200 | 12.645 | 12.753 | 12.861 | 12.969 | 13.077 | 13.185 | 13.292 | 13.400 | 13.508 | 13.615 | 13.723 |
| 1300 | 13.723 | 13.830 | 13.937 | 14.044 | 14.152 | 14.259 | 14.366 | 14.472 | 14.579 | 14.686 | 14.792 |
| 1400 | 14.792 | 14.899 | 15.005 | 15.112 | 15.218 | 15.324 | 15.430 | 15.535 | 15.641 | 15.747 | 15.852 |
| 1500 | 15.852 | 15.957 | 16.063 | 16.168 | 16.273 | 16.377 | 16.482 | 16.587 | 16.691 | 16.795 | 16.899 |
| 1600 | 16.899 | 17.003 | 17.107 | 17.211 | 17.315 | 17.418 | 17.521 | 17.624 | 17.727 | 17.830 | 17.933 |
| 1700 | 17.933 | 18.035 | 18.138 | 18.240 | 18.342 | 18.444 | 18.545 | 18.647 | 18.748 | 18.849 | 18.951 |
| 1800 | 18.951 | 19.051 | 19.152 | 19.253 | 19.353 | 19.453 | 19.553 | 19.653 | 19.753 | 19.852 | 19.952 |
| 1900 | 19.952 | 20.051 | 20.150 | 20.249 | 20.347 | 20.446 | 20.544 | 20.642 | 20.740 | 20.838 | 20.936 |
| 2000 | 20.936 | 21.033 | 21.130 | 21.227 | 21.324 | 21.421 | 21.517 | 21.614 | 21.710 | 21.806 | 21.902 |
| 2100 | 21.902 | 21.997 | 22.093 | 22.188 | 22.283 | 22.378 | 22.472 | 22.567 | 22.661 | 22.755 | 22.849 |
| 2200 | 22.849 | 22.943 | 23.037 | 23.130 | 23.223 | 23.316 | 23.409 | 23.502 | 23.594 | 23.686 | 23.778 |
| 2300 | 23.778 | 23.870 | 23.962 | 24.053 | 24.145 | 24.236 | 24.327 | 24.418 | 24.508 | 24.599 | 24.689 |
| 2400 | 24.689 | 24.779 | 24.869 | 24.958 | 25.048 | 25.137 | 25.226 | 25.315 | 25.404 | 25.492 | 25.581 |
| 2500 | 25.581 | 25.669 | 25.757 | 25.844 | 25.932 | 26.019 | 26.107 | 26.194 | 26.280 | 26.367 | 26.454 |
| 2600 | 26.454 | 26.540 | 26.626 | 26.712 | 26.798 | 26.883 | 26.968 | 27.054 | 27.139 | 27.223 | 27.308 |
| 2700 | 27.308 | 27.392 | 27.477 | 27.561 | 27.645 | 27.728 | 27.812 | 27.895 | 27.978 | 28.061 | 28.144 |
| 2800 | 28.144 | 28.226 | 28.309 | 28.391 | 28.473 | 28.555 | 28.636 | 28.718 | 28.799 | 28.880 | 28.961 |
| 2900 | 28.961 | 29.041 | 29.122 | 29.202 | 29.282 | 29.362 | 29.442 | 29.521 | 29.601 | 29.680 | 29.759 |
| 3000 | 29.759 | 29.838 | 29.916 | 29.995 | 30.073 | 30.151 | 30.229 | 30.306 | 30.384 | 30.461 | 30.538 |
| 3100 | 30.538 | 30.615 | 30.691 | 30.768 | 30.844 | 30.920 | 30.996 | 31.071 | 31.147 | 31.222 | 31.297 |
| 3200 | 31.297 | 31.372 | 31.447 | 31.521 | 31.595 | 31.669 | 31.743 | 31.817 | 31.890 | 31.963 | 32.036 |
| 3300 | 32.036 | 32.109 | 32.182 | 32.254 | 32.326 | 32.398 | 32.470 | 32.542 | 32.613 | 32.684 | 32.755 |
| 3400 | 32.755 | 32.825 | 32.896 | 32.966 | 33.036 | 33.106 | 33.175 | 33.245 | 33.314 | 33.383 | 33.451 |
| 3500 | 33.451 | 33.520 | 33.588 | 33.656 | 33.723 | 33.791 | 33.858 | 33.925 | 33.992 | 34.058 | 34.124 |
| 3600 | 34.124 | 34.190 | 34.256 | 34.321 | 34.387 | 34.452 | 34.516 | 34.581 | 34.645 | 34.709 | 34.772 |
| 3700 | 34.772 | 34.836 | 34.899 | 34.962 | 35.024 | 35.087 | 35.149 | 35.211 | 35.272 | 35.333 | 35.394 |
| 3800 | 35.394 | 35.455 | 35.515 | 35.575 | 35.635 | 35.694 | 35.753 | 35.812 | 35.871 | 35.929 | 35.987 |
| 3900 | 35.987 | 36.044 | 36.102 | 36.159 | 36.215 | 36.271 | 36.327 | 36.383 | 36.438 | 36.493 | 36.548 |
| 4000 | 36.548 | 36.602 | 36.656 | 36.710 | 36.763 | 36.816 | 36.868 | 36.921 | 36.972 | 37.024 | 37.075 |
| 4100 | | | | | | | | | | | |

Type J

Iron vs Constantan ITS-90

Type K

Chromel vs Alumel ITS-90

| °C | 0 | -10 | -20 | -30 | -40 | -50 | -60 | -70 | -80 | -90 | -100 |
|------|--------|--------|--------|--------|--------|--------|--------|--------|--------|--------|--------|
| -200 | -7.890 | -8.095 | | | | | | | | | |
| -100 | -4.633 | -5.037 | -5.426 | -5.801 | -6.159 | -6.500 | -6.821 | -7.123 | -7.403 | -7.659 | -7.890 |
| 0 | 0.000 | -0.501 | -0.995 | -1.482 | -1.961 | -2.431 | -2.893 | -3.344 | -3.786 | -4.215 | -4.633 |

| °C | 0 | -10 | -20 | -30 | -40 | -50 | -60 | -70 | -80 | -90 | -100 |
|------|--------|--------|--------|--------|--------|--------|--------|--------|--------|--------|--------|
| -200 | -5.891 | -6.035 | -6.158 | -6.262 | -6.344 | -6.404 | -6.441 | -6.469 | -6.483 | -6.488 | -6.488 |
| -100 | -3.554 | -3.852 | -4.138 | -4.411 | -4.669 | -4.913 | -5.141 | -5.354 | -5.550 | -5.730 | -5.891 |
| 0 | 0.000 | -0.392 | -0.778 | -1.156 | -1.527 | -1.889 | -2.243 | -2.587 | -2.920 | -3.243 | -3.554 |

| °C | 0 | 10 | 20 | 30 | 40 | 50 | 60 | 70 | 80 | 90 | 100 |
|------|--------|--------|--------|--------|--------|--------|--------|--------|--------|--------|--------|
| 0 | 0.000 | 0.507 | 1.019 | 1.537 | 2.059 | 2.585 | 3.116 | 3.650 | 4.187 | 4.726 | 5.269 |
| 100 | 5.269 | 5.814 | 6.360 | 6.909 | 7.459 | 8.010 | 8.562 | 9.115 | 9.669 | 10.224 | 10.779 |
| 200 | 10.779 | 11.334 | 11.889 | 12.445 | 13.000 | 13.555 | 14.110 | 14.665 | 15.219 | 15.773 | 16.327 |
| 300 | 16.327 | 16.881 | 17.434 | 17.986 | 18.538 | 19.090 | 19.642 | 20.194 | 20.745 | 21.297 | 21.848 |
| 400 | 21.848 | 22.400 | 22.952 | 23.504 | 24.057 | 24.610 | 25.164 | 25.720 | 26.276 | 26.834 | 27.393 |
| 500 | 27.393 | 27.953 | 28.516 | 29.080 | 29.647 | 30.216 | 30.788 | 31.362 | 31.939 | 32.519 | 33.102 |
| 600 | 33.102 | 33.689 | 34.279 | 34.873 | 35.470 | 36.071 | 36.675 | 37.284 | 37.896 | 38.512 | 39.132 |
| 700 | 39.132 | 39.755 | 40.382 | 41.012 | 41.645 | 42.281 | 42.919 | 43.559 | 44.203 | 44.848 | 45.494 |
| 800 | 45.494 | 46.141 | 46.786 | 47.431 | 48.074 | 48.715 | 49.353 | 49.989 | 50.622 | 51.251 | 51.877 |
| 900 | 51.877 | 52.500 | 53.119 | 53.735 | 54.347 | 54.956 | 55.561 | 56.164 | 56.763 | 57.360 | 57.953 |
| 1000 | 57.953 | 58.545 | 59.134 | 59.721 | 60.307 | 60.890 | 61.473 | 62.054 | 62.634 | 63.214 | 63.792 |
| 1100 | 63.792 | 64.370 | 64.948 | 65.525 | 66.102 | 66.679 | 67.255 | 67.831 | 68.406 | 68.980 | 69.553 |

| °C | 0 | 10 | 20 | 30 | 40 | 50 | 60 | 70 | 80 | 90 | 100 |
|------|--------|--------|--------|--------|--------|--------|--------|--------|--------|--------|--------|
| 0 | 0.000 | 0.397 | 0.798 | 1.203 | 1.612 | 2.023 | 2.436 | 2.851 | 3.267 | 3.682 | 4.096 |
| 100 | 4.096 | 4.509 | 4.920 | 5.328 | 5.735 | 6.138 | 6.540 | 6.941 | 7.340 | 7.739 | 8.138 |
| 200 | 8.138 | 8.539 | 8.940 | 9.343 | 9.747 | 10.153 | 10.561 | 10.971 | 11.382 | 11.795 | 12.209 |
| 300 | 12.209 | 12.624 | 13.040 | 13.457 | 13.874 | 14.293 | 14.713 | 15.133 | 15.554 | 15.975 | 16.397 |
| 400 | 16.397 | 16.820 | 17.243 | 17.667 | 18.091 | 18.516 | 18.941 | 19.366 | 19.792 | 20.218 | 20.644 |
| 500 | 20.644 | 21.071 | 21.497 | 21.924 | 22.350 | 22.776 | 23.203 | 23.629 | 24.055 | 24.480 | 24.905 |
| 600 | 24.905 | 25.330 | 25.755 | 26.179 | 26.602 | 27.025 | 27.447 | 27.869 | 28.289 | 28.710 | 29.129 |
| 700 | 29.129 | 29.548 | 29.965 | 30.382 | 30.798 | 31.213 | 31.628 | 32.041 | 32.453 | 32.865 | 33.275 |
| 800 | 33.275 | 33.685 | 34.093 | 34.501 | 34.908 | 35.313 | 35.718 | 36.121 | 36.524 | 36.925 | 37.326 |
| 900 | 37.326 | 37.725 | 38.124 | 38.522 | 38.918 | 39.314 | 39.708 | 40.101 | 40.494 | 40.885 | 41.276 |
| 1000 | 41.276 | 41.665 | 42.053 | 42.440 | 42.826 | 43.211 | 43.595 | 43.978 | 44.359 | 44.740 | 45.119 |
| 1100 | 45.119 | 45.497 | 45.873 | 46.249 | 46.623 | 46.995 | 47.367 | 47.737 | 48.105 | 48.473 | 48.838 |
| 1200 | 48.838 | 49.202 | 49.565 | 49.926 | 50.286 | 50.644 | 51.000 | 51.355 | 51.708 | 52.060 | 52.410 |
| 1300 | 52.410 | 52.759 | 53.106 | 53.451 | 53.795 | 54.138 | 54.479 | 54.819 | | | |

| °F | 0 | -10 | -20 | -30 | -40 | -50 | -60 | -70 | -80 | -90 | -100 |
|------|--------|--------|--------|--------|--------|--------|--------|--------|--------|--------|--------|
| -300 | -7.519 | -7.659 | -7.791 | -7.915 | -8.030 | | | | | | |
| -200 | -5.760 | -5.962 | -6.159 | -6.351 | -6.536 | -6.716 | -6.890 | -7.058 | -7.219 | -7.373 | -7.519 |
| -100 | -3.493 | -3.737 | -3.978 | -4.215 | -4.449 | -4.678 | -4.903 | -5.125 | -5.341 | -5.553 | -5.760 |
| 0 | -0.886 | -1.158 | -1.428 | -1.695 | -1.961 | -2.223 | -2.483 | -2.740 | -2.994 | -3.245 | -3.493 |

| °F | 0 | -10 | -20 | -30 | -40 | -50 | -60 | -70 | -80 | -90 | -100 |
|------|--------|--------|--------|--------|--------|--------|--------|--------|--------|--------|--------|
| -400 | -6.344 | -6.380 | -6.409 | -6.431 | -6.446 | -6.456 | -6.459 | -6.458 | -6.455 | -6.451 | -6.450 |
| -300 | -5.632 | -5.730 | -5.822 | -5.908 | -5.989 | -6.064 | -6.133 | -6.195 | -6.251 | -6.301 | -6.344 |
| -200 | -4.381 | -4.527 | -4.669 | -4.806 | -4.939 | -5.067 | -5.190 | -5.308 | -5.421 | -5.529 | -5.632 |
| -100 | -2.699 | -2.884 | -3.065 | -3.243 | -3.417 | -3.587 | -3.754 | -3.917 | -4.076 | -4.231 | -4.381 |
| 0 | -0.692 | -0.905 | -1.114 | -1.322 | -1.527 | -1.729 | -1.929 | -2.126 | -2.320 | -2.511 | -2.699 |

| °F | 0 | 10 | 20 | 30 | 40 | 50 | 60 | 70 | 80 | 90 | 100 |
|------|--------|--------|--------|--------|--------|--------|--------|--------|--------|--------|--------|
| 0 | -0.886 | -0.611 | -0.334 | -0.056 | 0.225 | 0.507 | 0.791 | 1.076 | 1.364 | 1.652 | 1.942 |
| 100 | 1.942 | 2.234 | 2.527 | 2.821 | 3.116 | 3.412 | 3.709 | 4.007 | 4.306 | 4.606 | 4.907 |
| 200 | 4.907 | 5.209 | 5.511 | 5.814 | 6.117 | 6.421 | 6.726 | 7.031 | 7.336 | 7.642 | 7.949 |
| 300 | 7.949 | 8.255 | 8.562 | 8.869 | 9.177 | 9.485 | 9.793 | 10.101 | 10.409 | 10.717 | 11.025 |
| 400 | 11.025 | 11.334 | 11.642 | 11.951 | 12.260 | 12.568 | 12.877 | 13.185 | 13.494 | 13.802 | 14.110 |
| 500 | 14.110 | 14.418 | 14.727 | 15.035 | 15.343 | 15.650 | 15.958 | 16.266 | 16.573 | 16.881 | 17.188 |
| 600 | 17.188 | 17.495 | 17.802 | 18.109 | 18.416 | 18.722 | 19.029 | 19.336 | 19.642 | 19.949 | 20.255 |
| 700 | 20.255 | 20.561 | 20.868 | 21.174 | 21.480 | 21.787 | 22.093 | 22.400 | 22.706 | 23.013 | 23.320 |
| 800 | 23.320 | 23.627 | 23.934 | 24.241 | 24.549 | 24.856 | 25.164 | 25.473 | 25.781 | 26.090 | 26.400 |
| 900 | 26.400 | 26.710 | 27.020 | 27.330 | 27.642 | 27.953 | 28.266 | 28.579 | 28.892 | 29.206 | 29.521 |
| 1000 | 29.521 | 29.836 | 30.153 | 30.470 | 30.788 | 31.106 | 31.426 | 31.746 | 32.068 | 32.390 | 32.713 |
| 1100 | 32.713 | 33.037 | 33.363 | 33.689 | 34.016 | 34.345 | 34.674 | 35.005 | 35.337 | 35.670 | 36.004 |
| 1200 | 36.004 | 36.339 | 36.675 | 37.013 | 37.352 | 37.692 | 38.033 | 38.375 | 38.718 | 39.063 | 39.408 |
| 1300 | 39.408 | 39.755 | 40.103 | 40.452 | 40.801 | 41.152 | 41.504 | 41.856 | 42.210 | 42.564 | 42.919 |
| 1400 | 42.919 | 43.274 | 43.631 | 43.988 | 44.346 | 44.705 | 45.064 | 45.423 | 45.782 | 46.141 | 46.500 |
| 1500 | 46.500 | 46.858 | 47.216 | 47.574 | 47.931 | 48.288 | 48.644 | 48.999 | 49.353 | 49.707 | 50.060 |
| 1600 | 50.060 | 50.411 | 50.762 | 51.112 | 51.460 | 51.808 | 52.154 | 52.500 | 52.844 | 53.188 | 53.530 |
| 1700 | 53.530 | 53.871 | 54.211 | 54.550 | 54.888 | 55.225 | 55.561 | 55.896 | 56.230 | 56.564 | 56.896 |
| 1800 | 56.896 | 57.227 | 57.558 | 57.888 | 58.217 | 58.545 | 58.872 | 59.199 | 59.526 | 59.851 | 60.177 |
| 1900 | 60.177 | 60.501 | 60.826 | 61.149 | 61.473 | 61.796 | 62.118 | 62.441 | 62.763 | 63.085 | 63.406 |
| 2000 | 63.406 | 63.728 | 64.049 | 64.370 | 64.691 | 65.012 | 65.333 | 65.654 | 65.974 | 66.295 | 66.615 |
| 2100 | 66.615 | 66.935 | 67.255 | 67.575 | 67.895 | 68.214 | 68.534 | 68.853 | 69.171 | 69.490 | |

| °F | 0 | 10 | 20 | 30 | 40 | 50 | 60 | 70 | 80 | 90 | 100 |
|------|--------|--------|--------|--------|--------|--------|--------|--------|--------|--------|--------|
| 0 | -0.692 | -0.478 | -0.262 | -0.044 | 0.176 | 0.397 | 0.619 | 0.843 | 1.068 | 1.294 | 1.521 |
| 100 | 1.521 | 1.749 | 1.977 | 2.207 | 2.436 | 2.667 | 2.897 | 3.128 | 3.359 | 3.590 | 3.820 |
| 200 | 3.820 | 4.050 | 4.280 | 4.509 | 4.738 | 4.965 | 5.192 | 5.419 | 5.644 | 5.869 | 6.094 |
| 300 | 6.094 | 6.317 | 6.540 | 6.763 | 6.985 | 7.207 | 7.429 | 7.650 | 7.872 | 8.094 | 8.316 |
| 400 | 8.316 | 8.539 | 8.761 | 8.985 | 9.208 | 9.432 | 9.657 | 9.882 | 10.108 | 10.334 | 10.561 |
| 500 | 10.561 | 10.789 | 11.017 | 11.245 | 11.474 | 11.703 | 11.933 | 12.163 | 12.393 | 12.624 | 12.855 |
| 600 | 12.855 | 13.086 | 13.318 | 13.549 | 13.782 | 14.014 | 14.247 | 14.479 | 14.713 | 14.946 | 15.179 |
| 700 | 15.179 | 15.413 | 15.647 | 15.881 | 16.116 | 16.350 | 16.585 | 16.820 | 17.055 | 17.290 | 17.526 |
| 800 | 17.526 | 17.761 | 17.997 | 18.233 | 18.469 | 18.705 | 18.941 | 19.177 | 19.414 | 19.650 | 19.887 |
| 900 | 19.887 | 20.123 | 20.360 | 20.597 | 20.834 | 21.071 | 21.308 | 21.544 | 21.781 | 22.018 | 22.255 |
| 1000 | 22.255 | 22.492 | 22.729 | 22.966 | 23.203 | 23.439 | 23.676 | 23.913 | 24.149 | 24.386 | 24.622 |
| 1100 | 24.622 | 24.858 | 25.094 | 25.330 | 25.566 | 25.802 | 26.037 | 26.273 | 26.508 | 26.743 | 26.978 |
| 1200 | 26.978 | 27.213 | 27.447 | 27.681 | 27.915 | 28.149 | 28.383 | 28.616 | 28.849 | 29.082 | 29.315 |
| 1300 | 29.315 | 29.548 | 29.780 | 30.012 | 30.243 | 30.475 | 30.706 | 30.937 | | | |

Technical Information

| Type N | | | | | | | | | | | | Type | | | | | | | | | | | |
|---------------------------|--------|--------|--------|--------|--------|--------|--------|--------|--------|--------|--------|---|--------|--------|--------|--------|--------|--------|--------|--------|--------|--------|--------|
| Nicrosil vs. Nisil ITS-90 | | | | | | | | | | | | Nickel-0.8% Cobalt vs. Nickel-18% Molybdenum ITS-90 | | | | | | | | | | | |
| °C | 0 | -10 | -20 | -30 | -40 | -50 | -60 | -70 | -80 | -90 | -100 | °C | 0 | -10 | -20 | -30 | -40 | -50 | -60 | -70 | -80 | -90 | -100 |
| -200 | -3.990 | -4.083 | -4.162 | -4.226 | -4.277 | -4.313 | -4.336 | -4.345 | | | | 0 | 0.000 | -0.365 | -0.720 | -1.067 | -1.404 | -1.732 | | | | | |
| -100 | -2.407 | -2.612 | -2.808 | -2.994 | -3.171 | -3.336 | -3.491 | -3.634 | -3.766 | -3.884 | -3.990 | °C | 0 | 10 | 20 | 30 | 40 | 50 | 60 | 70 | 80 | 90 | 100 |
| 0 | 0.000 | -0.260 | -0.518 | -0.772 | -1.023 | -1.269 | -1.509 | -1.744 | -1.972 | -2.193 | -2.407 | 0 | 0.000 | 0.373 | 0.756 | 1.146 | 1.545 | 1.951 | 2.365 | 2.787 | 3.215 | 3.650 | 4.092 |
| °C | 0 | 10 | 20 | 30 | 40 | 50 | 60 | 70 | 80 | 90 | 100 | 100 | 4.092 | 4.539 | 4.993 | 5.451 | 5.915 | 6.383 | 6.855 | 7.331 | 7.811 | 8.293 | 8.778 |
| 0 | 0.000 | 0.261 | 0.525 | 0.793 | 1.065 | 1.340 | 1.619 | 1.902 | 2.189 | 2.480 | 2.774 | 200 | 8.778 | 9.266 | 9.755 | 10.245 | 10.736 | 11.227 | 11.718 | 12.208 | 12.696 | 13.182 | 13.665 |
| 100 | 2.774 | 3.072 | 3.374 | 3.680 | 3.989 | 4.302 | 4.618 | 4.937 | 5.259 | 5.585 | 5.913 | 300 | 13.665 | 13.182 | 12.696 | 12.208 | 11.718 | 11.227 | 10.736 | 10.245 | 17.314 | 17.746 | 18.181 |
| 200 | 5.913 | 6.245 | 6.579 | 6.916 | 7.255 | 7.597 | 7.941 | 8.288 | 8.637 | 8.988 | 9.341 | 400 | 18.181 | 18.618 | 19.059 | 19.502 | 19.949 | 20.399 | 20.853 | 21.310 | 21.771 | 22.235 | 22.703 |
| 300 | 9.341 | 9.696 | 10.054 | 10.413 | 10.774 | 11.136 | 11.501 | 11.867 | 12.234 | 12.603 | 12.974 | 500 | 22.703 | 23.174 | 23.649 | 24.127 | 24.610 | 25.095 | 25.584 | 26.077 | 26.573 | 27.072 | 27.574 |
| 400 | 12.974 | 13.346 | 13.719 | 14.094 | 14.469 | 14.846 | 15.225 | 15.604 | 15.984 | 16.366 | 16.748 | 600 | 27.574 | 28.080 | 28.589 | 29.101 | 29.616 | 30.135 | 30.656 | 31.180 | 31.707 | 32.237 | 32.769 |
| 500 | 16.748 | 17.131 | 17.515 | 17.900 | 18.286 | 18.672 | 19.059 | 19.447 | 19.835 | 20.224 | 20.613 | 700 | 32.769 | 33.304 | 33.842 | 34.382 | 34.925 | 35.470 | 36.017 | 36.567 | 37.119 | 37.672 | 38.228 |
| 600 | 20.613 | 21.003 | 21.393 | 21.784 | 22.175 | 22.566 | 22.958 | 23.350 | 23.742 | 24.134 | 24.527 | 800 | 38.228 | 38.786 | 39.346 | 39.907 | 40.471 | 41.036 | 41.602 | 42.171 | 42.740 | 43.312 | 43.884 |
| 700 | 24.527 | 24.919 | 25.312 | 25.705 | 26.098 | 26.491 | 26.883 | 27.276 | 27.669 | 28.062 | 28.455 | 900 | 43.884 | 44.459 | 45.034 | 45.611 | 46.189 | 46.768 | 47.348 | 47.929 | 48.512 | 49.095 | 49.680 |
| 800 | 28.455 | 28.847 | 29.239 | 29.632 | 30.024 | 30.416 | 30.807 | 31.199 | 31.590 | 31.981 | 32.371 | 1000 | 49.680 | 50.265 | 50.852 | 51.439 | 52.027 | 52.617 | 53.207 | 53.797 | 54.389 | 54.981 | 55.574 |
| 900 | 32.371 | 32.761 | 33.151 | 33.541 | 33.930 | 34.319 | 34.707 | 35.095 | 35.482 | 35.869 | 36.256 | 1100 | 55.574 | 56.168 | 56.762 | 57.357 | 57.953 | 58.549 | 59.146 | 59.743 | 60.341 | 60.939 | 61.537 |
| 1000 | 36.256 | 36.641 | 37.027 | 37.411 | 37.795 | 38.179 | 38.562 | 38.944 | 39.326 | 39.706 | 40.087 | 1200 | 61.537 | 62.135 | 62.734 | 63.333 | 63.931 | 64.530 | 65.129 | 65.728 | 66.326 | 66.925 | 67.523 |
| 1100 | 40.087 | 40.466 | 40.845 | 41.223 | 41.600 | 41.976 | 42.352 | 42.727 | 43.101 | 43.474 | 43.846 | 1300 | 67.523 | 68.121 | 68.719 | 69.317 | 69.914 | 70.511 | 71.109 | 71.707 | 72.305 | 72.903 | 73.503 |
| 1200 | 43.846 | 44.218 | 44.588 | 44.958 | 45.326 | 45.694 | 46.060 | 46.425 | 46.789 | 47.152 | 47.513 | °F | 0 | 10 | 20 | 30 | 40 | 50 | 60 | 70 | 80 | 90 | 100 |
| °F | 0 | -10 | -20 | -30 | -40 | -50 | -60 | -70 | -80 | -90 | -100 | 0 | -0.642 | -0.444 | -0.244 | -0.041 | 0.165 | 0.373 | 0.585 | 0.799 | 1.015 | 1.234 | 1.455 |
| -400 | -4.277 | -4.299 | -4.316 | -4.330 | -4.339 | -4.344 | | | | | | 100 | 1.455 | 1.679 | 1.906 | 2.134 | 2.365 | 2.599 | 2.834 | 3.072 | 3.311 | 3.553 | 3.797 |
| -300 | -3.877 | -3.884 | -3.945 | -4.001 | -4.054 | -4.102 | -4.145 | -4.185 | -4.220 | -4.251 | -4.277 | 200 | 3.797 | 4.042 | 4.290 | 4.539 | 4.790 | 5.043 | 5.298 | 5.554 | 5.811 | 6.070 | 6.330 |
| -200 | -2.974 | -3.074 | -3.171 | -3.264 | -3.354 | -3.441 | -3.524 | -3.604 | -3.679 | -3.752 | -3.820 | 300 | 6.330 | 6.592 | 6.855 | 7.119 | 7.384 | 7.650 | 7.918 | 8.186 | 8.455 | 8.724 | 8.995 |
| -100 | -1.821 | -1.947 | -2.072 | -2.193 | -2.313 | -2.430 | -2.544 | -2.656 | -2.765 | -2.871 | -2.974 | 400 | 8.995 | 9.266 | 9.537 | 9.809 | 10.081 | 10.354 | 10.627 | 10.900 | 11.172 | 11.445 | 11.718 |
| 0 | -0.461 | -0.603 | -0.744 | -0.884 | -1.023 | -1.160 | -1.296 | -1.430 | -1.562 | -1.692 | -1.821 | 500 | 11.718 | 11.990 | 12.262 | 12.533 | 12.804 | 13.074 | 13.343 | 13.612 | 13.879 | 14.144 | 14.409 |
| °F | 0 | 10 | 20 | 30 | 40 | 50 | 60 | 70 | 80 | 90 | 100 | 600 | 14.409 | 14.671 | 14.932 | 15.191 | 15.448 | 15.703 | 15.955 | 16.205 | 16.451 | 16.695 | 16.932 |
| 0 | -0.461 | -0.318 | -0.174 | -0.029 | 0.116 | 0.261 | 0.407 | 0.555 | 0.703 | 0.853 | 1.004 | 700 | 16.932 | 17.170 | 17.410 | 17.650 | 17.891 | 18.132 | 18.375 | 18.618 | 18.863 | 19.108 | 19.354 |
| 100 | 1.004 | 1.156 | 1.309 | 1.463 | 1.619 | 1.776 | 1.934 | 2.093 | 2.253 | 2.415 | 2.577 | 800 | 19.354 | 19.601 | 19.850 | 20.099 | 20.349 | 20.601 | 20.853 | 21.107 | 21.361 | 21.617 | 21.874 |
| 200 | 2.577 | 2.741 | 2.906 | 3.072 | 3.240 | 3.408 | 3.578 | 3.748 | 3.920 | 4.093 | 4.267 | 900 | 21.874 | 22.131 | 22.390 | 22.651 | 22.912 | 23.174 | 23.437 | 23.702 | 23.968 | 24.234 | 24.502 |
| 300 | 4.267 | 4.442 | 4.618 | 4.795 | 4.973 | 5.152 | 5.332 | 5.512 | 5.694 | 5.877 | 6.060 | 1000 | 24.502 | 24.771 | 25.041 | 25.312 | 25.584 | 25.857 | 26.132 | 26.407 | 26.683 | 26.961 | 27.239 |
| 400 | 6.060 | 6.245 | 6.430 | 6.616 | 6.803 | 6.991 | 7.179 | 7.369 | 7.559 | 7.750 | 7.941 | 1100 | 27.239 | 27.518 | 27.799 | 28.080 | 28.362 | 28.646 | 28.930 | 29.215 | 29.502 | 29.789 | 30.077 |
| 500 | 7.941 | 8.134 | 8.327 | 8.520 | 8.715 | 8.910 | 9.105 | 9.302 | 9.499 | 9.696 | 9.895 | 1200 | 30.077 | 30.366 | 30.656 | 30.947 | 31.239 | 31.531 | 31.825 | 32.119 | 32.414 | 32.710 | 33.007 |
| 600 | 9.895 | 10.093 | 10.293 | 10.493 | 10.693 | 10.894 | 11.096 | 11.298 | 11.501 | 11.704 | 11.907 | 1300 | 33.007 | 33.304 | 33.603 | 33.902 | 34.202 | 34.503 | 34.804 | 35.106 | 35.409 | 35.713 | 36.017 |
| 700 | 11.907 | 12.111 | 12.316 | 12.521 | 12.726 | 12.932 | 13.139 | 13.346 | 13.553 | 13.760 | 13.969 | 1400 | 36.017 | 36.322 | 36.628 | 36.934 | 37.241 | 37.549 | 37.857 | 38.166 | 38.476 | 38.786 | 39.097 |
| 800 | 13.969 | 14.177 | 14.386 | 14.595 | 14.804 | 15.014 | 15.225 | 15.435 | 15.646 | 15.857 | 16.069 | 1500 | 39.097 | 39.408 | 39.720 | 40.032 | 40.345 | 40.659 | 40.973 | 41.287 | 41.602 | 41.918 | 42.234 |
| 900 | 16.069 | 16.281 | 16.493 | 16.705 | 16.918 | 17.131 | 17.344 | 17.558 | 17.772 | 17.986 | 18.200 | 1600 | 42.234 | 42.550 | 42.867 | 43.185 | 43.502 | 43.821 | 44.139 | 44.459 | 44.778 | 45.098 | 45.418 |
| 1000 | 18.200 | 18.414 | 18.629 | 18.844 | 19.059 | 19.274 | 19.490 | 19.705 | 19.921 | 20.137 | 20.353 | 1700 | 45.418 | 45.739 | 46.060 | 46.381 | 46.703 | 47.025 | 47.348 | 47.671 | 47.994 | 48.318 | 48.641 |
| 1100 | 20.353 | 20.570 | 20.786 | 21.003 | 21.220 | 21.437 | 21.654 | 21.871 | 22.088 | 22.305 | 22.523 | 1800 | 48.641 | 48.966 | 49.290 | 49.615 | 49.940 | 50.265 | 50.591 | 50.917 | 51.243 | 51.570 | 51.897 |
| 1200 | 22.523 | 22.740 | 22.958 | 23.176 | 23.393 | 23.611 | 23.829 | 24.047 | 24.265 | 24.483 | 24.701 | 1900 | 51.897 | 52.224 | 52.551 | 52.879 | 53.207 | 53.535 | 53.863 | 54.192 | 54.520 | 54.850 | 55.179 |
| 1300 | 24.701 | 24.919 | 25.137 | 25.356 | 25.574 | 25.792 | 26.010 | 26.229 | 26.447 | 26.665 | 26.883 | 2000 | 55.179 | 55.508 | 55.838 | 56.168 | 56.498 | 56.829 | 57.159 | 57.490 | 57.821 | 58.152 | 58.483 |
| 1400 | 26.883 | 27.102 | 27.320 | 27.538 | 27.756 | 27.975 | 28.193 | 28.411 | 28.629 | 28.847 | 29.065 | 2100 | 58.483 | 58.814 | 59.146 | 59.478 | 59.809 | 60.141 | 60.473 | 60.806 | 61.138 | 61.470 | 61.803 |
| 1500 | 29.065 | 29.283 | 29.501 | 29.719 | 29.937 | 30.154 | 30.372 | 30.590 | 30.807 | 31.025 | 31.242 | 2200 | 61.803 | 62.135 | 62.468 | 62.800 | 63.133 | 63.466 | 63.798 | 64.131 | 64.464 | 64.796 | 65.129 |
| 1600 | 31.242 | 31.459 | 31.677 | 31.894 | 32.111 | 32.328 | 32.545 | 32.761 | 32.978 | 33.195 | 33.411 | 2300 | 65.129 | 65.462 | 65.794 | 66.127 | 66.459 | 66.792 | 67.124 | 67.457 | 67.789 | 68.121 | 68.453 |
| 1700 | 33.411 | 33.627 | 33.844 | 34.060 | 34.276 | 34.491 | 34.707 | 34.923 | 35.138 | 35.353 | 35.568 | 2400 | 68.453 | 68.785 | 69.117 | 69.449 | 69.781 | 70.113 | 70.445 | 70.777 | 71.109 | 71.441 | 71.773 |
| 1800 | 35.568 | 35.783 | 35.998 | 36.213 | 36.427 | 36.641 | 36.855 | 37.069 | 37.283 | 37.497 | 37.710 | 2500 | 71.773 | 72.105 | 72.438 | 72.770 | 73.103 | 73.436 | 73.770 | 74.104 | | | |
| 1900 | 37.710 | 37.923 | 38.136 | 38.349 | 38.562 | 38.774 | 38.986 | 39.198 | 39.410 | 39.622 | 39.833 | | | | | | | | | | | | |
| 2000 | 39.833 | 40.044 | 40.255 | 40.466 | 40.677 | 40.887 | 41.097 | 41.307 | 41.516 | 41.725 | 41.935 | | | | | | | | | | | | |
| 2100 | 41.935 | 42.143 | 42.352 | 42.560 | 42.768 | 42.976 | 43.184 | 43.391 | 43.598 | 43.805 | 44.012 | | | | | | | | | | | | |
| 2200 | 44.012 | 44.218 | 44.424 | 44.629 | 44.835 | 45.040 | 45.245 | 45.449 | 45.653 | 45.857 | 46.060 | | | | | | | | | | | | |
| 2300 | 46.060 | 46.263 | 46.466 | 46.668 | 46.870 | 47.071 | 47.272 | 47.473 | | | | | | | | | | | | | | | |

Type Platinel II

Alloy 5355 vs Alloy 7674 ITS-90

Type R

Platinum vs. Platinum-13% Rodium ITS-90

| °C | 0 | 10 | 20 | 30 | 40 | 50 | 60 | 70 | 80 | 90 | 100 |
|------|--------|--------|--------|--------|--------|--------|--------|--------|--------|--------|--------|
| 0 | 0.000 | 0.302 | 0.610 | 0.925 | 1.247 | 1.575 | 1.908 | 2.248 | 2.593 | 2.944 | 3.300 |
| 100 | 3.300 | 3.661 | 4.028 | 4.399 | 4.774 | 5.154 | 5.538 | 5.926 | 6.319 | 6.715 | 7.115 |
| 200 | 7.115 | 7.518 | 7.924 | 8.334 | 8.747 | 9.163 | 9.581 | 10.003 | 10.427 | 10.853 | 11.281 |
| 300 | 11.281 | 11.712 | 12.145 | 12.580 | 13.016 | 13.454 | 13.894 | 14.335 | 14.778 | 15.222 | 15.667 |
| 400 | 15.667 | 16.113 | 16.560 | 17.008 | 17.456 | 17.905 | 18.355 | 18.806 | 19.256 | 19.707 | 20.158 |
| 500 | 20.158 | 20.610 | 21.061 | 21.512 | 21.963 | 22.414 | 22.865 | 23.315 | 23.765 | 24.214 | 24.663 |
| 600 | 24.663 | 25.111 | 25.558 | 26.005 | 26.450 | 26.895 | 27.338 | 27.781 | 28.222 | 28.662 | 29.101 |
| 700 | 29.101 | 29.538 | 29.974 | 30.408 | 30.841 | 31.272 | 31.702 | 32.130 | 32.557 | 32.982 | 33.406 |
| 800 | 33.406 | 33.828 | 34.249 | 34.668 | 35.086 | 35.502 | 35.916 | 36.328 | 36.739 | 37.148 | 37.556 |
| 900 | 37.556 | 37.961 | 38.365 | 38.767 | 39.167 | 39.565 | 39.962 | 40.356 | 40.749 | 41.140 | 41.529 |
| 1000 | 41.529 | 41.915 | 42.300 | 42.683 | 43.064 | 43.443 | 43.820 | 44.195 | 44.568 | 44.939 | 45.308 |
| 1100 | 45.308 | 45.675 | 46.040 | 46.403 | 46.764 | 47.123 | 47.480 | 47.835 | 48.187 | 48.538 | 48.887 |
| 1200 | 48.887 | 49.233 | 49.578 | 49.920 | 50.261 | 50.599 | 50.935 | 51.269 | 51.601 | 51.931 | 52.258 |
| 1300 | 52.258 | 52.584 | 52.907 | 53.228 | 53.546 | 53.863 | 54.177 | 54.488 | 54.798 | 55.104 | |

| °F | 0 | 10 | 20 | 30 | 40 | 50 | 60 | 70 | 80 | 90 | 100 |
|------|--------|--------|--------|--------|--------|--------|--------|--------|--------|--------|--------|
| 0 | | | | | 0.133 | 0.302 | 0.472 | 0.645 | 0.820 | 0.996 | 1.175 |
| 100 | 1.175 | 1.355 | 1.538 | 1.722 | 1.908 | 2.096 | 2.286 | 2.478 | 2.671 | 2.866 | 3.062 |
| 200 | 3.062 | 3.260 | 3.460 | 3.661 | 3.864 | 4.069 | 4.274 | 4.482 | 4.690 | 4.900 | 5.111 |
| 300 | 5.111 | 5.324 | 5.538 | 5.753 | 5.970 | 6.188 | 6.406 | 6.626 | 6.848 | 7.070 | 7.293 |
| 400 | 7.293 | 7.518 | 7.743 | 7.970 | 8.197 | 8.426 | 8.655 | 8.885 | 9.117 | 9.349 | 9.581 |
| 500 | 9.581 | 9.815 | 10.050 | 10.285 | 10.521 | 10.758 | 10.995 | 11.234 | 11.473 | 11.712 | 11.952 |
| 600 | 11.952 | 12.193 | 12.434 | 12.676 | 12.919 | 13.162 | 13.405 | 13.649 | 13.894 | 14.139 | 14.384 |
| 700 | 14.384 | 14.630 | 14.876 | 15.123 | 15.370 | 15.617 | 15.865 | 16.113 | 16.361 | 16.609 | 16.858 |
| 800 | 16.858 | 17.107 | 17.356 | 17.606 | 17.855 | 18.105 | 18.355 | 18.605 | 18.856 | 19.106 | 19.356 |
| 900 | 19.356 | 19.607 | 19.858 | 20.108 | 20.359 | 20.610 | 20.860 | 21.111 | 21.362 | 21.613 | 21.863 |
| 1000 | 21.863 | 22.114 | 22.364 | 22.615 | 22.865 | 23.115 | 23.365 | 23.615 | 23.865 | 24.115 | 24.364 |
| 1100 | 24.364 | 24.613 | 24.862 | 25.111 | 25.360 | 25.608 | 25.856 | 26.104 | 26.351 | 26.599 | 26.845 |
| 1200 | 26.845 | 27.092 | 27.338 | 27.584 | 27.830 | 28.075 | 28.320 | 28.564 | 28.808 | 29.052 | 29.295 |
| 1300 | 29.295 | 29.538 | 29.780 | 30.022 | 30.264 | 30.505 | 30.745 | 30.985 | 31.225 | 31.463 | 31.702 |
| 1400 | 31.702 | 31.940 | 32.178 | 32.415 | 32.652 | 32.888 | 33.124 | 33.359 | 33.594 | 33.828 | 34.062 |
| 1500 | 34.062 | 34.296 | 34.529 | 34.761 | 34.993 | 35.225 | 35.456 | 35.686 | 35.916 | 36.145 | 36.374 |
| 1600 | 36.374 | 36.603 | 36.830 | 37.058 | 37.284 | 37.511 | 37.736 | 37.961 | 38.186 | 38.410 | 38.633 |
| 1700 | 38.633 | 38.856 | 39.078 | 39.300 | 39.521 | 39.742 | 39.962 | 40.181 | 40.400 | 40.618 | 40.836 |
| 1800 | 40.836 | 41.053 | 41.270 | 41.485 | 41.701 | 41.915 | 42.129 | 42.343 | 42.556 | 42.768 | 42.980 |
| 1900 | 42.980 | 43.191 | 43.401 | 43.611 | 43.820 | 44.029 | 44.237 | 44.444 | 44.651 | 44.857 | 45.063 |
| 2000 | 45.063 | 45.267 | 45.472 | 45.675 | 45.878 | 46.081 | 46.282 | 46.484 | 46.684 | 46.884 | 47.083 |
| 2100 | 47.083 | 47.282 | 47.480 | 47.677 | 47.874 | 48.070 | 48.265 | 48.460 | 48.654 | 48.848 | 49.041 |
| 2200 | 49.041 | 49.233 | 49.425 | 49.616 | 49.806 | 49.996 | 50.185 | 50.374 | 50.561 | 50.748 | 50.935 |
| 2300 | 50.935 | 51.121 | 51.306 | 51.490 | 51.674 | 51.858 | 52.040 | 52.222 | 52.403 | 52.584 | 52.763 |
| 2400 | 52.763 | 52.942 | 53.121 | 53.299 | 53.476 | 53.652 | 53.828 | 54.003 | 54.177 | 54.350 | 54.523 |
| 2500 | 54.523 | 54.695 | 54.866 | 55.036 | 55.206 | 55.375 | 55.543 | 55.710 | 55.876 | 56.042 | 56.207 |

| °C | 0 | 10 | 20 | 30 | 40 | 50 | 60 | 70 | 80 | 90 | 100 |
|------|--------|--------|--------|--------|--------|--------|--------|--------|--------|--------|--------|
| 0 | 0.000 | 0.054 | 0.111 | 0.171 | 0.232 | 0.296 | 0.363 | 0.431 | 0.501 | 0.573 | 0.647 |
| 100 | 0.647 | 0.723 | 0.800 | 0.879 | 0.959 | 1.041 | 1.124 | 1.208 | 1.294 | 1.381 | 1.469 |
| 200 | 1.469 | 1.558 | 1.648 | 1.739 | 1.831 | 1.923 | 2.017 | 2.112 | 2.207 | 2.304 | 2.401 |
| 300 | 2.401 | 2.498 | 2.597 | 2.696 | 2.796 | 2.896 | 2.997 | 3.099 | 3.201 | 3.304 | 3.408 |
| 400 | 3.408 | 3.512 | 3.616 | 3.721 | 3.827 | 3.933 | 4.040 | 4.147 | 4.255 | 4.363 | 4.471 |
| 500 | 4.471 | 4.580 | 4.690 | 4.800 | 4.910 | 5.021 | 5.133 | 5.245 | 5.357 | 5.470 | 5.583 |
| 600 | 5.583 | 5.697 | 5.812 | 5.926 | 6.041 | 6.157 | 6.273 | 6.390 | 6.507 | 6.625 | 6.743 |
| 700 | 6.743 | 6.861 | 6.980 | 7.100 | 7.220 | 7.340 | 7.461 | 7.583 | 7.705 | 7.827 | 7.950 |
| 800 | 7.950 | 8.073 | 8.197 | 8.321 | 8.446 | 8.571 | 8.697 | 8.823 | 8.950 | 9.077 | 9.205 |
| 900 | 9.205 | 9.333 | 9.461 | 9.590 | 9.720 | 9.850 | 9.980 | 10.111 | 10.242 | 10.374 | 10.506 |
| 1000 | 10.506 | 10.638 | 10.771 | 10.905 | 11.039 | 11.173 | 11.307 | 11.442 | 11.578 | 11.714 | 11.850 |
| 1100 | 11.850 | 11.986 | 12.123 | 12.260 | 12.397 | 12.535 | 12.673 | 12.812 | 12.950 | 13.089 | 13.228 |
| 1200 | 13.228 | 13.367 | 13.507 | 13.646 | 13.786 | 13.926 | 14.066 | 14.207 | 14.347 | 14.488 | 14.629 |
| 1300 | 14.629 | 14.770 | 14.911 | 15.052 | 15.193 | 15.334 | 15.475 | 15.616 | 15.758 | 15.899 | 16.040 |
| 1400 | 16.040 | 16.181 | 16.323 | 16.464 | 16.605 | 16.746 | 16.887 | 17.028 | 17.169 | 17.310 | 17.451 |
| 1500 | 17.451 | 17.591 | 17.732 | 17.872 | 18.012 | 18.152 | 18.292 | 18.431 | 18.571 | 18.710 | 18.849 |
| 1600 | 18.849 | 18.988 | 19.126 | 19.264 | 19.402 | 19.540 | 19.677 | 19.814 | 19.951 | 20.087 | 20.222 |
| 1700 | 20.222 | 20.356 | 20.488 | 20.620 | 20.749 | 20.877 | 21.003 | | | | |

| °F | 0 | 10 | 20 | 30 | 40 | 50 | 60 | 70 | 80 | 90 | 100 |
|------|--------|--------|--------|--------|--------|--------|--------|--------|--------|--------|--------|
| 0 | -0.090 | -0.063 | -0.035 | -0.006 | 0.024 | 0.054 | 0.086 | 0.118 | 0.151 | 0.184 | 0.218 |
| 100 | 0.218 | 0.254 | 0.289 | 0.326 | 0.363 | 0.400 | 0.439 | 0.478 | 0.517 | 0.557 | 0.598 |
| 200 | 0.598 | 0.629 | 0.681 | 0.723 | 0.766 | 0.809 | 0.853 | 0.897 | 0.941 | 0.986 | 1.032 |
| 300 | 1.032 | 1.078 | 1.124 | 1.171 | 1.218 | 1.265 | 1.313 | 1.361 | 1.410 | 1.459 | 1.508 |
| 400 | 1.508 | 1.558 | 1.607 | 1.658 | 1.708 | 1.759 | 1.810 | 1.861 | 1.913 | 1.965 | 2.017 |
| 500 | 2.017 | 2.070 | 2.122 | 2.175 | 2.229 | 2.282 | 2.336 | 2.390 | 2.444 | 2.498 | 2.553 |
| 600 | 2.553 | 2.608 | 2.663 | 2.718 | 2.773 | 2.829 | 2.885 | 2.941 | 2.997 | 3.054 | 3.110 |
| 700 | 3.110 | 3.167 | 3.224 | 3.281 | 3.339 | 3.396 | 3.454 | 3.512 | 3.570 | 3.628 | 3.686 |
| 800 | 3.686 | 3.745 | 3.803 | 3.862 | 3.921 | 3.980 | 4.040 | 4.099 | 4.159 | 4.219 | 4.279 |
| 900 | 4.279 | 4.339 | 4.399 | 4.459 | 4.520 | 4.580 | 4.641 | 4.702 | 4.763 | 4.824 | 4.886 |
| 1000 | 4.886 | 4.947 | 5.009 | 5.071 | 5.133 | 5.195 | 5.257 | 5.320 | 5.382 | 5.445 | 5.508 |
| 1100 | 5.508 | 5.571 | 5.634 | 5.697 | 5.761 | 5.824 | 5.888 | 5.952 | 6.016 | 6.080 | 6.144 |
| 1200 | 6.144 | 6.209 | 6.273 | 6.338 | 6.403 | 6.468 | 6.533 | 6.598 | 6.664 | 6.730 | 6.795 |
| 1300 | 6.795 | 6.861 | 6.927 | 6.994 | 7.060 | 7.126 | 7.193 | 7.260 | 7.327 | 7.394 | 7.461 |
| 1400 | 7.461 | 7.529 | 7.596 | 7.664 | 7.732 | 7.800 | 7.868 | 7.936 | 8.005 | 8.073 | 8.142 |
| 1500 | 8.142 | 8.211 | 8.280 | 8.349 | 8.418 | 8.488 | 8.557 | 8.627 | 8.697 | 8.767 | 8.837 |
| 1600 | 8.837 | 8.908 | 8.978 | 9.049 | 9.120 | 9.191 | 9.262 | 9.333 | 9.404 | 9.476 | 9.547 |
| 1700 | 9.547 | 9.619 | 9.691 | 9.763 | 9.835 | 9.908 | 9.980 | 10.053 | 10.126 | 10.198 | 10.271 |
| 1800 | 10.271 | 10.345 | 10.418 | 10.491 | 10.565 | 10.638 | 10.712 | 10.786 | 10.860 | 10.934 | 11.009 |
| 1900 | 11.009 | 11.083 | 11.158 | 11.233 | 11.307 | 11.382 | 11.457 | 11.533 | 11.608 | 11.683 | 11.759 |
| 2000 | 11.759 | 11.834 | 11.910 | 11.986 | 12.062 | 12.138 | 12.214 | 12.291 | 12.367 | 12.443 | 12.520 |
| 2100 | 12.520 | 12.597 | 12.673 | 12.750 | 12.827 | 12.904 | 12.981 | 13.058 | 13.135 | 13.213 | 13.290 |
| 2200 | 13.290 | 13.367 | 13.445 | 13.522 | 13.600 | 13.677 | 13.755 | 13.833 | 13.911 | 13.989 | 14.066 |
| 2300 | 14.066 | 14.144 | 14.222 | 14.300 | 14.379 | 14.457 | 14.535 | 14.613 | 14.691 | 14.770 | 14.848 |
| 2400 | 14.848 | 14.926 | 15.005 | 15.083 | 15.161 | 15.240 | 15.318 | 15.397 | 15.475 | 15.553 | 15.632 |
| 2500 | 15.632 | 15.710 | 15.789 | 15.867 | 15.946 | 16.024 | 16.103 | 16.181 | 16.260 | 16.338 | 16.417 |
| 2600 | 16.417 | 16.495 | 16.574 | 16.652 | 16.731 | 16.809 | 16.887 | 16.966 | 17.044 | 17.122 | 17.200 |
| 2700 | 17.200 | 17.279 | 17.357 | 17.435 | 17.513 | 17.591 | 17.669 | 17.747 | 17.825 | 17.903 | 17.981 |
| 2800 | 17.981 | 18.059 | 18.137 | 18.214 | 18.292 | 18.369 | 18.447 | 18.524 | 18.602 | 18.679 | 18.756 |
| 2900 | 18.756 | 18.834 | 18.911 | 18.988 | 19.065 | 19.141 | 19.218 | 19.295 | 19.372 | 19.448 | 19.525 |
| 3000 | 19.525 | 19.601 | 19.677 | 19.753 | 19.829 | 19.905 | 19.981 | 20.056 | 20.132 | 20.207 | 20.281 |
| 3100 | 20.281 | 20.356 | 2 | | | | | | | | |

Type Tungsten-3% Rhenium vs Tungsten-25% Rhenium ITS-90

Type Tungsten-3% Rhenium vs Tungsten-25% Rhenium ITS-90

| °C | 0 | 10 | 20 | 30 | 40 | 50 | 60 | 70 | 80 | 90 | 100 |
|------|--------|--------|--------|--------|--------|--------|--------|--------|--------|--------|--------|
| 0 | 0.000 | 0.098 | 0.200 | 0.305 | 0.415 | 0.528 | 0.645 | 0.765 | 0.888 | 1.015 | 1.145 |
| 100 | 1.145 | 1.278 | 1.415 | 1.554 | 1.696 | 1.841 | 1.988 | 2.138 | 2.290 | 2.445 | 2.603 |
| 200 | 2.603 | 2.762 | 2.924 | 3.088 | 3.253 | 3.421 | 3.591 | 3.762 | 3.936 | 4.111 | 4.287 |
| 300 | 4.287 | 4.465 | 4.645 | 4.826 | 5.009 | 5.192 | 5.378 | 5.564 | 5.752 | 5.940 | 6.130 |
| 400 | 6.130 | 6.321 | 6.513 | 6.706 | 6.899 | 7.094 | 7.289 | 7.485 | 7.682 | 7.880 | 8.078 |
| 500 | 8.078 | 8.277 | 8.476 | 8.676 | 8.877 | 9.078 | 9.279 | 9.481 | 9.683 | 9.885 | 10.088 |
| 600 | 10.088 | 10.291 | 10.494 | 10.698 | 10.901 | 11.105 | 11.309 | 11.512 | 11.716 | 11.921 | 12.125 |
| 700 | 12.125 | 12.329 | 12.533 | 12.737 | 12.942 | 13.146 | 13.351 | 13.555 | 13.760 | 13.965 | 14.170 |
| 800 | 14.170 | 14.375 | 14.580 | 14.784 | 14.989 | 15.193 | 15.398 | 15.602 | 15.805 | 16.009 | 16.212 |
| 900 | 16.212 | 16.415 | 16.618 | 16.821 | 17.023 | 17.225 | 17.427 | 17.628 | 17.829 | 18.029 | 18.230 |
| 1000 | 18.230 | 18.430 | 18.629 | 18.828 | 19.027 | 19.225 | 19.423 | 19.621 | 19.818 | 20.014 | 20.211 |
| 1100 | 20.211 | 20.406 | 20.602 | 20.797 | 20.991 | 21.185 | 21.379 | 21.572 | 21.765 | 21.957 | 22.149 |
| 1200 | 22.149 | 22.340 | 22.531 | 22.721 | 22.911 | 23.100 | 23.289 | 23.477 | 23.665 | 23.853 | 24.040 |
| 1300 | 24.040 | 24.226 | 24.412 | 24.598 | 24.783 | 24.967 | 25.151 | 25.335 | 25.517 | 25.700 | 25.882 |
| 1400 | 25.882 | 26.063 | 26.244 | 26.425 | 26.605 | 26.784 | 26.963 | 27.141 | 27.319 | 27.497 | 27.673 |
| 1500 | 27.673 | 27.850 | 28.026 | 28.201 | 28.375 | 28.550 | 28.723 | 28.896 | 29.069 | 29.241 | 29.412 |
| 1600 | 29.412 | 29.583 | 29.753 | 29.923 | 30.092 | 30.260 | 30.428 | 30.595 | 30.762 | 30.928 | 31.093 |
| 1700 | 31.093 | 31.258 | 31.422 | 31.586 | 31.749 | 31.911 | 32.072 | 32.233 | 32.393 | 32.553 | 32.712 |
| 1800 | 32.712 | 32.870 | 33.027 | 33.183 | 33.339 | 33.494 | 33.648 | 33.802 | 33.954 | 34.106 | 34.257 |
| 1900 | 34.257 | 34.407 | 34.556 | 34.705 | 34.852 | 34.999 | 35.144 | 35.289 | 35.433 | 35.575 | 35.717 |
| 2000 | 35.717 | 35.858 | 35.997 | 36.136 | 36.273 | 36.409 | 36.544 | 36.678 | 36.811 | 36.942 | 37.073 |
| 2100 | 37.073 | 37.202 | 37.329 | 37.456 | 37.580 | 37.704 | 37.826 | 37.947 | 38.066 | 38.183 | 38.299 |
| 2200 | 38.299 | 38.414 | 38.527 | 38.638 | 38.747 | 38.855 | 38.961 | 39.065 | 39.167 | 39.267 | 39.365 |

| °F | 0 | 10 | 20 | 30 | 40 | 50 | 60 | 70 | 80 | 90 | 100 |
|------|--------|--------|--------|--------|--------|--------|--------|--------|--------|--------|--------|
| 0 | | | | | 0.043 | 0.098 | 0.154 | 0.211 | 0.270 | 0.329 | 0.390 |
| 100 | 0.390 | 0.452 | 0.515 | 0.579 | 0.645 | 0.711 | 0.778 | 0.847 | 0.916 | 0.987 | 1.058 |
| 200 | 1.058 | 1.131 | 1.204 | 1.278 | 1.354 | 1.430 | 1.507 | 1.585 | 1.664 | 1.744 | 1.824 |
| 300 | 1.824 | 1.906 | 1.988 | 2.071 | 2.155 | 2.239 | 2.325 | 2.411 | 2.497 | 2.585 | 2.673 |
| 400 | 2.673 | 2.762 | 2.852 | 2.942 | 3.033 | 3.124 | 3.216 | 3.309 | 3.402 | 3.496 | 3.591 |
| 500 | 3.591 | 3.686 | 3.781 | 3.878 | 3.974 | 4.071 | 4.169 | 4.267 | 4.366 | 4.465 | 4.565 |
| 600 | 4.565 | 4.665 | 4.766 | 4.866 | 4.968 | 5.070 | 5.172 | 5.275 | 5.378 | 5.481 | 5.585 |
| 700 | 5.585 | 5.689 | 5.793 | 5.898 | 6.003 | 6.109 | 6.215 | 6.321 | 6.427 | 6.534 | 6.641 |
| 800 | 6.641 | 6.749 | 6.856 | 6.964 | 7.072 | 7.181 | 7.289 | 7.398 | 7.507 | 7.617 | 7.726 |
| 900 | 7.726 | 7.836 | 7.946 | 8.056 | 8.167 | 8.277 | 8.388 | 8.499 | 8.610 | 8.721 | 8.832 |
| 1000 | 8.832 | 8.944 | 9.055 | 9.167 | 9.279 | 9.391 | 9.503 | 9.616 | 9.728 | 9.840 | 9.953 |
| 1100 | 9.953 | 10.066 | 10.178 | 10.291 | 10.404 | 10.517 | 10.630 | 10.743 | 10.856 | 10.969 | 11.082 |
| 1200 | 11.082 | 11.195 | 11.309 | 11.422 | 11.535 | 11.648 | 11.762 | 11.875 | 11.989 | 12.102 | 12.215 |
| 1300 | 12.215 | 12.329 | 12.442 | 12.556 | 12.669 | 12.783 | 12.896 | 13.010 | 13.123 | 13.237 | 13.351 |
| 1400 | 13.351 | 13.464 | 13.578 | 13.692 | 13.806 | 13.920 | 14.033 | 14.147 | 14.261 | 14.375 | 14.489 |
| 1500 | 14.489 | 14.603 | 14.716 | 14.830 | 14.944 | 15.057 | 15.171 | 15.284 | 15.398 | 15.511 | 15.624 |
| 1600 | 15.624 | 15.737 | 15.851 | 15.964 | 16.077 | 16.190 | 16.303 | 16.415 | 16.528 | 16.641 | 16.753 |
| 1700 | 16.753 | 16.866 | 16.978 | 17.090 | 17.203 | 17.315 | 17.427 | 17.538 | 17.650 | 17.762 | 17.873 |
| 1800 | 17.873 | 17.985 | 18.096 | 18.207 | 18.319 | 18.430 | 18.540 | 18.651 | 18.762 | 18.872 | 18.983 |
| 1900 | 18.983 | 19.093 | 19.203 | 19.313 | 19.423 | 19.533 | 19.643 | 19.752 | 19.861 | 19.971 | 20.080 |
| 2000 | 20.080 | 20.189 | 20.298 | 20.406 | 20.515 | 20.624 | 20.732 | 20.840 | 20.948 | 21.056 | 21.164 |
| 2100 | 21.164 | 21.271 | 21.379 | 21.486 | 21.593 | 21.700 | 21.807 | 21.914 | 22.021 | 22.127 | 22.234 |
| 2200 | 22.234 | 22.340 | 22.446 | 22.552 | 22.658 | 22.763 | 22.869 | 22.974 | 23.079 | 23.184 | 23.289 |
| 2300 | 23.289 | 23.394 | 23.498 | 23.603 | 23.707 | 23.811 | 23.915 | 24.019 | 24.123 | 24.226 | 24.330 |
| 2400 | 24.330 | 24.433 | 24.536 | 24.639 | 24.742 | 24.844 | 24.947 | 25.049 | 25.151 | 25.253 | 25.355 |
| 2500 | 25.355 | 25.457 | 25.558 | 25.659 | 25.761 | 25.862 | 25.963 | 26.063 | 26.164 | 26.264 | 26.365 |
| 2600 | 26.365 | 26.465 | 26.565 | 26.665 | 26.764 | 26.864 | 26.963 | 27.062 | 27.161 | 27.260 | 27.359 |
| 2700 | 27.359 | 27.457 | 27.556 | 27.654 | 27.752 | 27.850 | 27.947 | 28.045 | 28.142 | 28.240 | 28.337 |
| 2800 | 28.337 | 28.434 | 28.530 | 28.627 | 28.723 | 28.819 | 28.915 | 29.011 | 29.107 | 29.202 | 29.298 |
| 2900 | 29.298 | 29.393 | 29.488 | 29.583 | 29.677 | 29.772 | 29.866 | 29.960 | 30.054 | 30.148 | 30.241 |
| 3000 | 30.241 | 30.335 | 30.428 | 30.521 | 30.614 | 30.706 | 30.799 | 30.891 | 30.983 | 31.075 | 31.167 |
| 3100 | 31.167 | 31.258 | 31.349 | 31.440 | 31.531 | 31.622 | 31.713 | 31.803 | 31.893 | 31.983 | 32.072 |
| 3200 | 32.072 | 32.162 | 32.251 | 32.340 | 32.429 | 32.517 | 32.606 | 32.694 | 32.782 | 32.870 | 32.957 |
| 3300 | 32.957 | 33.044 | 33.131 | 33.218 | 33.305 | 33.391 | 33.477 | 33.563 | 33.648 | 33.734 | 33.819 |
| 3400 | 33.819 | 33.904 | 33.988 | 34.073 | 34.157 | 34.240 | 34.324 | 34.407 | 34.490 | 34.573 | 34.655 |
| 3500 | 34.655 | 34.738 | 34.820 | 34.901 | 34.983 | 35.064 | 35.144 | 35.225 | 35.305 | 35.385 | 35.464 |
| 3600 | 35.464 | 35.544 | 35.623 | 35.701 | 35.780 | 35.858 | 35.935 | 36.013 | 36.090 | 36.166 | 36.243 |
| 3700 | 36.243 | 36.319 | 36.394 | 36.469 | 36.544 | 36.619 | 36.693 | 36.767 | 36.840 | 36.913 | 36.986 |
| 3800 | 36.986 | 37.058 | 37.130 | 37.202 | 37.273 | 37.343 | 37.414 | 37.483 | 37.553 | 37.622 | 37.690 |
| 3900 | 37.690 | 37.758 | 37.826 | 37.893 | 37.960 | 38.026 | 38.092 | 38.157 | 38.222 | 38.287 | 38.351 |
| 4000 | 38.351 | 38.414 | 38.477 | 38.539 | 38.601 | 38.662 | 38.723 | 38.783 | 38.843 | 38.902 | 38.961 |
| 4100 | 38.961 | 39.019 | 39.076 | 39.133 | 39.189 | 39.245 | 39.300 | 39.354 | 39.408 | 39.461 | 39.514 |

Technical Information

| Type Tungsten vs Tungsten-26% Rhenium ITS-90 | | | | | | | | | | | | Type Tungsten vs Tungsten-26% Rhenium ITS-90 | | | | | | | | | | | |
|--|--------|--------|--------|--------|--------|--------|--------|--------|--------|--------|--------|--|--------|--------|--------|--------|--------|--------|--------|--------|--------|--------|--------|
| °C | 0 | 10 | 20 | 30 | 40 | 50 | 60 | 70 | 80 | 90 | 100 | °F | 0 | 10 | 20 | 30 | 40 | 50 | 60 | 70 | 80 | 90 | 100 |
| 0 | 0.000 | 0.015 | 0.034 | 0.058 | 0.085 | 0.117 | 0.152 | 0.192 | 0.235 | 0.282 | 0.333 | 0 | 0.006 | 0.015 | 0.025 | 0.037 | 0.049 | 0.063 | 0.079 | 0.1027 | 1.076 | | |
| 100 | 0.333 | 0.388 | 0.446 | 0.508 | 0.573 | 0.642 | 0.715 | 0.790 | 0.869 | 0.951 | 1.037 | 100 | 0.079 | 0.095 | 0.113 | 0.132 | 0.152 | 0.174 | 0.196 | 0.220 | 0.245 | 0.272 | 0.299 |
| 200 | 1.037 | 1.125 | 1.217 | 1.311 | 1.409 | 1.509 | 1.613 | 1.719 | 1.828 | 1.940 | 2.055 | 200 | 0.299 | 0.327 | 0.357 | 0.388 | 0.420 | 0.453 | 0.487 | 0.522 | 0.559 | 0.596 | 0.634 |
| 300 | 2.055 | 2.172 | 2.292 | 2.414 | 2.539 | 2.666 | 2.796 | 2.928 | 3.063 | 3.200 | 3.339 | 300 | 0.634 | 0.674 | 0.715 | 0.756 | 0.799 | 0.842 | 0.887 | 0.933 | 0.979 | 1.027 | 1.076 |
| 400 | 3.339 | 3.480 | 3.624 | 3.769 | 3.917 | 4.067 | 4.219 | 4.372 | 4.528 | 4.685 | 4.845 | 400 | 1.076 | 1.125 | 1.176 | 1.227 | 1.279 | 1.333 | 1.387 | 1.442 | 1.498 | 1.555 | 1.613 |
| 500 | 4.845 | 5.006 | 5.169 | 5.334 | 5.500 | 5.668 | 5.837 | 6.008 | 6.181 | 6.355 | 6.531 | 500 | 1.613 | 1.672 | 1.731 | 1.792 | 1.853 | 1.915 | 1.978 | 2.042 | 2.106 | 2.172 | 2.238 |
| 600 | 6.531 | 6.707 | 6.886 | 7.065 | 7.246 | 7.428 | 7.611 | 7.796 | 7.982 | 8.169 | 8.357 | 600 | 2.238 | 2.305 | 2.373 | 2.442 | 2.511 | 2.581 | 2.652 | 2.724 | 2.796 | 2.869 | 2.943 |
| 700 | 8.357 | 8.546 | 8.737 | 8.928 | 9.120 | 9.314 | 9.508 | 9.704 | 9.900 | 10.097 | 10.295 | 700 | 2.943 | 3.018 | 3.093 | 3.169 | 3.246 | 3.323 | 3.401 | 3.480 | 3.560 | 3.640 | 3.721 |
| 800 | 10.295 | 10.494 | 10.694 | 10.894 | 11.095 | 11.297 | 11.500 | 11.703 | 11.907 | 12.111 | 12.316 | 800 | 3.721 | 3.802 | 3.884 | 3.967 | 4.050 | 4.134 | 4.219 | 4.304 | 4.389 | 4.476 | 4.563 |
| 900 | 12.316 | 12.522 | 12.728 | 12.934 | 13.141 | 13.349 | 13.557 | 13.765 | 13.974 | 14.183 | 14.392 | 900 | 4.563 | 4.650 | 4.738 | 4.827 | 4.916 | 5.006 | 5.096 | 5.187 | 5.278 | 5.370 | 5.463 |
| 1000 | 14.392 | 14.602 | 14.812 | 15.022 | 15.232 | 15.443 | 15.654 | 15.865 | 16.076 | 16.287 | 16.498 | 1000 | 5.463 | 5.556 | 5.649 | 5.743 | 5.837 | 5.932 | 6.027 | 6.123 | 6.220 | 6.316 | 6.413 |
| 1100 | 16.498 | 16.710 | 16.921 | 17.133 | 17.345 | 17.556 | 17.768 | 17.979 | 18.191 | 18.402 | 18.614 | 1100 | 6.413 | 6.511 | 6.609 | 6.707 | 6.806 | 6.905 | 7.005 | 7.105 | 7.206 | 7.306 | 7.408 |
| 1200 | 18.614 | 18.825 | 19.036 | 19.247 | 19.458 | 19.669 | 19.880 | 20.090 | 20.300 | 20.510 | 20.720 | 1200 | 7.408 | 7.509 | 7.611 | 7.714 | 7.816 | 7.920 | 8.023 | 8.127 | 8.231 | 8.336 | 8.441 |
| 1300 | 20.720 | 20.929 | 21.138 | 21.347 | 21.556 | 21.764 | 21.972 | 22.180 | 22.387 | 22.594 | 22.800 | 1300 | 8.441 | 8.546 | 8.652 | 8.758 | 8.864 | 8.971 | 9.078 | 9.185 | 9.292 | 9.400 | 9.508 |
| 1400 | 22.800 | 23.006 | 23.212 | 23.417 | 23.622 | 23.826 | 24.030 | 24.234 | 24.437 | 24.639 | 24.841 | 1400 | 9.508 | 9.617 | 9.725 | 9.834 | 9.944 | 10.053 | 10.163 | 10.273 | 10.383 | 10.494 | 10.605 |
| 1500 | 24.841 | 25.042 | 25.243 | 25.444 | 25.643 | 25.843 | 26.041 | 26.239 | 26.437 | 26.633 | 26.829 | 1500 | 10.605 | 10.716 | 10.827 | 10.939 | 11.051 | 11.162 | 11.275 | 11.387 | 11.500 | 11.612 | 11.725 |
| 1600 | 26.829 | 27.025 | 27.220 | 27.414 | 27.607 | 27.800 | 27.992 | 28.184 | 28.374 | 28.564 | 28.753 | 1600 | 11.725 | 11.839 | 11.952 | 12.066 | 12.179 | 12.293 | 12.407 | 12.522 | 12.636 | 12.751 | 12.865 |
| 1700 | 28.753 | 28.942 | 29.129 | 29.316 | 29.502 | 29.688 | 29.872 | 30.056 | 30.239 | 30.421 | 30.602 | 1700 | 12.865 | 12.980 | 13.095 | 13.210 | 13.326 | 13.441 | 13.557 | 13.672 | 13.788 | 13.904 | 14.020 |
| 1800 | 30.602 | 30.782 | 30.962 | 31.140 | 31.318 | 31.495 | 31.671 | 31.846 | 32.020 | 32.193 | 32.365 | 1800 | 14.020 | 14.136 | 14.252 | 14.369 | 14.485 | 14.602 | 14.718 | 14.835 | 14.952 | 15.069 | 15.185 |
| 1900 | 32.365 | 32.536 | 32.707 | 32.876 | 33.044 | 33.212 | 33.378 | 33.543 | 33.708 | 33.871 | 34.033 | 1900 | 15.185 | 15.302 | 15.419 | 15.536 | 15.654 | 15.771 | 15.888 | 16.005 | 16.123 | 16.240 | 16.357 |
| 2000 | 34.033 | 34.195 | 34.355 | 34.514 | 34.672 | 34.829 | 34.985 | 35.140 | 35.294 | 35.447 | 35.598 | 2000 | 16.357 | 16.475 | 16.592 | 16.710 | 16.827 | 16.945 | 17.062 | 17.180 | 17.298 | 17.415 | 17.533 |
| 2100 | 35.598 | 35.749 | 35.898 | 36.046 | 36.193 | 36.339 | 36.484 | 36.627 | 36.770 | 36.911 | 37.051 | 2100 | 17.533 | 17.650 | 17.768 | 17.885 | 18.003 | 18.120 | 18.238 | 18.355 | 18.473 | 18.590 | 18.708 |
| 2200 | 37.051 | 37.189 | 37.327 | 37.463 | 37.598 | 37.732 | 37.864 | 37.995 | 38.125 | 38.253 | 38.380 | 2200 | 18.708 | 18.825 | 18.942 | 19.060 | 19.177 | 19.294 | 19.411 | 19.528 | 19.646 | 19.763 | 19.880 |
| 2300 | 38.380 | 38.506 | | | | | | | | | | 2300 | 19.880 | 19.996 | 20.113 | 20.230 | 20.347 | 20.463 | 20.580 | 20.696 | 20.813 | 20.929 | 21.045 |
| | | | | | | | | | | | | 2400 | 21.045 | 21.162 | 21.278 | 21.394 | 21.509 | 21.625 | 21.741 | 21.857 | 21.972 | 22.087 | 22.203 |
| | | | | | | | | | | | | 2500 | 22.203 | 22.318 | 22.433 | 22.548 | 22.663 | 22.777 | 22.892 | 23.006 | 23.121 | 23.235 | 23.349 |
| | | | | | | | | | | | | 2600 | 23.349 | 23.463 | 23.577 | 23.690 | 23.804 | 23.917 | 24.030 | 24.143 | 24.256 | 24.369 | 24.482 |
| | | | | | | | | | | | | 2700 | 24.482 | 24.594 | 24.707 | 24.819 | 24.931 | 25.042 | 25.154 | 25.266 | 25.377 | 25.488 | 25.599 |
| | | | | | | | | | | | | 2800 | 25.599 | 25.710 | 25.820 | 25.931 | 26.041 | 26.151 | 26.261 | 26.371 | 26.480 | 26.590 | 26.699 |
| | | | | | | | | | | | | 2900 | 26.699 | 26.808 | 26.916 | 27.025 | 27.133 | 27.241 | 27.349 | 27.457 | 27.564 | 27.672 | 27.779 |
| | | | | | | | | | | | | 3000 | 27.779 | 27.886 | 27.992 | 28.099 | 28.205 | 28.311 | 28.416 | 28.522 | 28.627 | 28.732 | 28.837 |
| | | | | | | | | | | | | 3100 | 28.837 | 28.942 | 29.046 | 29.150 | 29.254 | 29.358 | 29.461 | 29.564 | 29.667 | 29.770 | 29.872 |
| | | | | | | | | | | | | 3200 | 29.872 | 29.974 | 30.076 | 30.178 | 30.279 | 30.380 | 30.481 | 30.582 | 30.682 | 30.782 | 30.882 |
| | | | | | | | | | | | | 3300 | 30.882 | 30.982 | 31.081 | 31.180 | 31.279 | 31.377 | 31.475 | 31.573 | 31.671 | 31.768 | 31.865 |
| | | | | | | | | | | | | 3400 | 31.865 | 31.962 | 32.058 | 32.154 | 32.250 | 32.346 | 32.441 | 32.536 | 32.631 | 32.725 | 32.820 |
| | | | | | | | | | | | | 3500 | 32.820 | 32.913 | 33.007 | 33.100 | 33.193 | 33.286 | 33.378 | 33.470 | 33.562 | 33.653 | 33.744 |
| | | | | | | | | | | | | 3600 | 33.744 | 33.835 | 33.925 | 34.015 | 34.105 | 34.195 | 34.284 | 34.373 | 34.461 | 34.549 | 34.637 |
| | | | | | | | | | | | | 3700 | 34.637 | 34.725 | 34.812 | 34.899 | 34.985 | 35.072 | 35.157 | 35.243 | 35.328 | 35.413 | 35.497 |
| | | | | | | | | | | | | 3800 | 35.497 | 35.582 | 35.665 | 35.749 | 35.832 | 35.915 | 35.997 | 36.079 | 36.161 | 36.242 | 36.323 |
| | | | | | | | | | | | | 3900 | 36.323 | 36.404 | 36.484 | 36.564 | 36.643 | 36.722 | 36.801 | 36.880 | 36.958 | 37.035 | 37.113 |
| | | | | | | | | | | | | 4000 | 37.113 | 37.189 | 37.266 | 37.342 | 37.418 | 37.493 | 37.568 | 37.643 | 37.717 | 37.791 | 37.864 |
| | | | | | | | | | | | | 4100 | 37.864 | 37.937 | 38.009 | 38.082 | 38.153 | 38.225 | 38.296 | 38.366 | 38.436 | 38.506 | 38.575 |

100Ω RTD

0.00385 Ω/Ω/°C ITS-90

100Ω RTD

0.003911 Ω/Ω/°C IPTS-68

| °C | 0 | -10 | -20 | -30 | -40 | -50 | -60 | -70 | -80 | -90 | -100 |
|------|--------|--------|--------|--------|--------|--------|--------|--------|--------|--------|--------|
| -100 | 60.26 | 56.19 | 52.11 | 48.00 | 43.88 | 39.72 | 35.54 | 31.34 | 27.10 | 22.83 | 18.52 |
| 0 | 100.00 | 96.09 | 92.16 | 88.22 | 84.27 | 80.31 | 76.33 | 72.33 | 68.33 | 64.30 | 60.26 |
| °C | 0 | 10 | 20 | 30 | 40 | 50 | 60 | 70 | 80 | 90 | 100 |
| 0 | 100.00 | 103.90 | 107.79 | 111.67 | 115.54 | 119.40 | 123.24 | 127.08 | 130.90 | 134.71 | 138.51 |
| 100 | 138.51 | 142.29 | 146.07 | 149.83 | 153.58 | 157.33 | 161.05 | 164.77 | 168.48 | 172.17 | 175.86 |
| 200 | 175.86 | 179.53 | 183.19 | 186.84 | 190.47 | 194.10 | 197.71 | 201.31 | 204.90 | 208.48 | 212.05 |
| 300 | 212.05 | 215.61 | 219.15 | 222.68 | 226.21 | 229.72 | 233.21 | 236.70 | 240.18 | 243.64 | 247.09 |
| 400 | 247.09 | 250.53 | 253.96 | 257.38 | 260.78 | 264.18 | 267.56 | 270.93 | 274.29 | 277.64 | 280.98 |
| 500 | 280.98 | 284.30 | 287.62 | 290.92 | 294.21 | 297.49 | 300.75 | 304.01 | 307.25 | 310.49 | 313.71 |
| 600 | 313.71 | 316.92 | 320.12 | 323.30 | 326.48 | 329.64 | | | | | |
| °F | 0 | -10 | -20 | -30 | -40 | -50 | -60 | -70 | -80 | -90 | -100 |
| -300 | 25.20 | 22.83 | 20.44 | | | | | | | | |
| -200 | 48.46 | 46.17 | 43.88 | 41.57 | 39.26 | 36.94 | 34.61 | 32.27 | 29.93 | 27.57 | 25.20 |
| -100 | 71.00 | 68.77 | 66.54 | 64.30 | 62.06 | 59.81 | 57.55 | 55.29 | 53.02 | 50.74 | 48.46 |
| 0 | 93.03 | 90.85 | 88.66 | 86.47 | 84.27 | 82.07 | 79.86 | 77.66 | 75.44 | 73.22 | 71.00 |
| °F | 0 | 10 | 20 | 30 | 40 | 50 | 60 | 70 | 80 | 90 | 100 |
| 0 | 93.03 | 95.21 | 97.39 | 99.57 | 101.74 | 103.90 | 106.07 | 108.23 | 110.38 | 112.53 | 114.68 |
| 100 | 114.68 | 116.83 | 118.97 | 121.11 | 123.24 | 125.37 | 127.50 | 129.62 | 131.74 | 133.86 | 135.97 |
| 200 | 135.97 | 138.08 | 140.19 | 142.29 | 144.39 | 146.49 | 148.58 | 150.67 | 152.75 | 154.83 | 156.91 |
| 300 | 156.91 | 158.98 | 161.05 | 163.12 | 165.18 | 167.24 | 169.30 | 171.35 | 173.40 | 175.45 | 177.49 |
| 400 | 177.49 | 179.53 | 181.56 | 183.59 | 185.62 | 187.65 | 189.67 | 191.68 | 193.70 | 195.71 | 197.71 |
| 500 | 197.71 | 199.71 | 201.71 | 203.71 | 205.70 | 207.69 | 209.67 | 211.66 | 213.63 | 215.61 | 217.58 |
| 600 | 217.58 | 219.55 | 221.51 | 223.47 | 225.42 | 227.38 | 229.33 | 231.27 | 233.21 | 235.15 | 237.09 |
| 700 | 237.09 | 239.02 | 240.95 | 242.87 | 244.79 | 246.71 | 248.62 | 250.53 | 252.44 | 254.34 | 256.24 |
| 800 | 256.24 | 258.14 | 260.03 | 261.92 | 263.80 | 265.68 | 267.56 | 269.44 | 271.31 | 273.17 | 275.04 |
| 900 | 275.04 | 276.90 | 278.75 | 280.61 | 282.46 | 284.30 | 286.14 | 287.98 | 289.82 | 291.65 | 293.48 |
| 1000 | 293.48 | 295.30 | 297.12 | 298.94 | 300.75 | 302.56 | 304.37 | 306.17 | 307.97 | 309.77 | 311.56 |
| 1100 | 311.56 | 313.35 | 315.14 | 316.92 | 318.70 | 320.47 | 322.24 | 324.01 | 325.77 | 327.53 | 329.29 |

| °C | 0 | -10 | -20 | -30 | -40 | -50 | -60 | -70 | -80 | -90 | -100 |
|------|--------|--------|--------|--------|--------|--------|--------|--------|--------|--------|--------|
| -100 | 59.64 | 55.51 | 51.37 | 47.20 | 43.01 | 38.79 | 34.54 | 30.27 | 25.97 | 21.63 | 17.26 |
| 0 | 100.00 | 96.03 | 92.04 | 88.04 | 84.03 | 80.00 | 75.96 | 71.91 | 67.83 | 63.75 | 59.64 |
| °C | 0 | 10 | 20 | 30 | 40 | 50 | 60 | 70 | 80 | 90 | 100 |
| 0 | 100.00 | 103.96 | 107.92 | 111.86 | 115.78 | 119.70 | 123.60 | 127.50 | 131.38 | 135.25 | 139.11 |
| 100 | 139.11 | 142.95 | 146.79 | 150.61 | 154.42 | 158.22 | 162.01 | 165.79 | 169.55 | 173.30 | 177.04 |
| 200 | 177.04 | 180.77 | 184.49 | 188.20 | 191.89 | 195.57 | 199.24 | 202.90 | 206.55 | 210.19 | 213.81 |
| 300 | 213.81 | 217.42 | 221.02 | 224.61 | 228.19 | 231.76 | 235.31 | 238.85 | 242.38 | 245.90 | 249.41 |
| 400 | 249.41 | 252.90 | 256.39 | 259.86 | 263.32 | 266.77 | 270.21 | 273.63 | 277.04 | 280.45 | 283.84 |
| 500 | 283.84 | 287.21 | 290.58 | 293.94 | 297.28 | 300.61 | 303.93 | 307.24 | 310.54 | 313.82 | 317.09 |
| 600 | 317.09 | 320.36 | 323.61 | 326.84 | 330.07 | 333.28 | | | | | |
| °F | 0 | -10 | -20 | -30 | -40 | -50 | -60 | -70 | -80 | -90 | -100 |
| -300 | 24.04 | 21.63 | 19.21 | | | | | | | | |
| -200 | 47.66 | 45.34 | 43.01 | 40.67 | 38.32 | 35.96 | 33.60 | 31.22 | 28.84 | 26.45 | 24.04 |
| -100 | 70.55 | 68.29 | 66.02 | 63.75 | 61.47 | 59.18 | 56.89 | 54.59 | 52.29 | 49.98 | 47.66 |
| 0 | 92.93 | 90.71 | 88.48 | 86.26 | 84.03 | 81.79 | 79.55 | 77.31 | 75.06 | 72.81 | 70.55 |
| °F | 0 | 10 | 20 | 30 | 40 | 50 | 60 | 70 | 80 | 90 | 100 |
| 0 | 92.93 | 95.14 | 97.35 | 99.56 | 101.76 | 103.96 | 106.16 | 108.35 | 110.54 | 112.73 | 114.91 |
| 100 | 114.91 | 117.09 | 119.27 | 121.44 | 123.61 | 125.77 | 127.93 | 130.09 | 132.24 | 134.39 | 136.54 |
| 200 | 136.54 | 138.68 | 140.82 | 142.95 | 145.08 | 147.21 | 149.34 | 151.46 | 153.58 | 155.69 | 157.80 |
| 300 | 157.80 | 159.91 | 162.01 | 164.11 | 166.20 | 168.30 | 170.38 | 172.47 | 174.55 | 176.63 | 178.70 |
| 400 | 178.70 | 180.77 | 182.84 | 184.90 | 186.96 | 189.02 | 191.07 | 193.12 | 195.16 | 197.21 | 199.24 |
| 500 | 199.24 | 201.28 | 203.31 | 205.34 | 207.36 | 209.38 | 211.40 | 213.41 | 215.42 | 217.42 | 219.42 |
| 600 | 219.42 | 221.42 | 223.42 | 225.41 | 227.40 | 229.38 | 231.36 | 233.34 | 235.31 | 237.28 | 239.24 |
| 700 | 239.24 | 241.21 | 243.17 | 245.12 | 247.07 | 249.02 | 250.96 | 252.90 | 254.84 | 256.77 | 258.70 |
| 800 | 258.70 | 260.63 | 262.55 | 264.47 | 266.39 | 268.30 | 270.21 | 272.11 | 274.01 | 275.91 | 277.80 |
| 900 | 277.80 | 279.69 | 281.58 | 283.46 | 285.34 | 287.21 | 289.09 | 290.95 | 292.82 | 294.68 | 296.54 |
| 1000 | 296.54 | 298.39 | 300.24 | 302.09 | 303.93 | 305.77 | 307.61 | 309.44 | 311.27 | 313.09 | 314.91 |
| 1100 | 314.91 | 316.73 | 318.55 | 320.36 | 322.16 | 323.97 | 325.77 | 327.56 | 329.35 | 331.14 | 332.93 |

