

# Industrial Sensors

## Anatomy of a Model Number

### Introduction

The model number is made up of fifteen fields. Each field, or series of fields, contains a code, or codes, that represents a specific feature of the product.

This section of the book is devoted to sensors designed primarily for industrial application. Two types of sensors are listed: thermocouples and resistance temperature detectors.

This section tells you how to identify the specifications of a thermocouple from the model number.

### Analyzing a Model Number

#### Fields 1, 2

##### Type of Sensor

The code of the first one or two fields identifies the type of sensor. The code in field 1 of a thermocouple part number indicates the calibration (type) of wire. The first field of an RTD contains the letter R; the code in field 2 represents the resistance coefficient



Model No.  -  -  -  -

	Base Metal T/C					Noble Metal T/C					RTD	
Code	J	K	E	T	N	B	S	F	C	R	R5	R7
	Field 1										Fields 1, 2	

#### Fields 2, 3

Fields 2 and 3 of a thermocouple part number represent the gauge (size) of the wire. Field 3 of an RTD part number represents the accuracy and temperature rating of the sensor.

#### Field 4

##### Number of Elements, Junction Style and Tube Configuration

This is a key identification code of an industrial thermocouple part number. The standard junction style of an industrial thermocouple is considered to be twisted, grounded.



Model No.  -  -  -  -

The code in field 4 identifies the junction style and is unique to a tube configuration:

- Straight Tube ..... Pages 3-4, 3-12, 3-14, 3-16, 3-18, 3-20
- I - Single, twisted, grounded
- H - Dual, twisted, grounded
- 90° Elbow Tube ..... Page 3-7
- L - Single, twisted, grounded
- J - Dual, twisted, grounded
- 90° Bent Tube ..... Page 3-10
- A - Single, twisted, grounded
- K - Dual, twisted, grounded

Field 4 code of an RTD part number identifies the number of elements and wires ..... Page 3-28

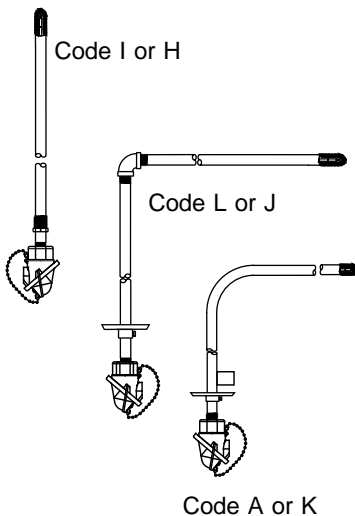

# Industrial Sensors

## Analyzing a Model Number (continued)

### Fields 5, 6

#### Protection Tube (Diameter, Material)

The factory provides industrial thermocouples with metal pipe, metal tube, and ceramic tube protection, in diameters up to 1-3/4". Noble metal thermocouples are available with single, dual and triple tube protection. See compatibility table under "Thermocouple Elements" in the "Wire and Accessories" section.

Industrial RTDs are available with and without flexible lead protection.

### Field 7

#### Cold End Termination (Thermocouple); or Flexible Lead Material (RTD)

Your thermocouple can be fitted with an aluminum or cast iron head for either general purpose or weatherproof application.

In an RTD part number, this field indicates the type of material of the flexible lead protection – none, armor, or stainless steel overbraid.

Cold end termination in an RTD model number is in Fields 14, 15.

### Fields 8, 9

#### Hot Length (or Hot Leg)

This field is the length, in inches, of the portion of the protection tube that holds the junction. In a straight configuration this is the entire tube. In a 90° configuration, it is from the elbow or bend to the tip.

### Field 10

#### Hot End (Thermocouple); or Flexible Lead Length (RTD)



Model No. □□□□ - □□□□□ - □□□ - □ - □□

#### Base Metal

0 - Straight tube, closed end

8 - Straight tube, open end

#### Noble Metal

0 - Single ceramic tube; closed end

1 - Dual ceramic tubes; closed end

2 - Ceramic primary tube; silicone carbide outer tube

3 - Ceramic primary and secondary tube; silicone carbide outer tube

6 - Ceramic primary tube; Inconel 601 outer tube

#### RTD

Fields 10, 11, 12 is the length, in inches, of the flexible lead specified in Field 7.

### Fields 11, 12

#### Cold Length (CL) (90° Configuration); or Tube Seal (Noble Metal); or Flexible Length (RTD)

For a base metal thermocouple in a 90° tube, the fields indicate the length, in inches, from the head (cold end termination) to the elbow or bend. In a noble metal thermocouple model number, the code in field 11 indicates whether or not the tube is sealed, and Field 12 is code 0.

Fields 10, 11, 12 of the RTD part number is the length, in inches, of the flexible lead specified in Field 7.

### Field 13

#### Mounting Fitting

The code in this field indicates the type of process mount.

### Fields 14, 15

#### Mounting Fitting Location ("U" Dimension); or Cold End Termination (RTD)

The code in this field indicates, in inches, the location of the welded bushing on a metal protection tube. Or, in an RTD model number, it indicates the type of cold end termination.

# Industrial Sensors

## Element Compatibility

The element you select from Field 4 of the tables on the following pages must be compatible with the protection tube selected from Fields 5, 6 and the wire gauge selected from Fields 2, 3. The following table shows the element codes (Field 4) that are compatible with each protection tube/wire gauge combination. Note: "I" is the letter "I," not the numeral "1."

Fields 5, 6. Protection Tube		Fields 2, 3. Wire Gauge Codes		
		08 or 09	14 or 15	20 or 21
01	Cast iron coated	I, 2, 3, 4, H, 5, 6, L, C, E, F, J, G, M	I, 2, 3, 4, H, 5, 6, L, C, E, F, J, G, M	
02	Black steel, 1/4" NPS	n/a		
03	Black steel, 1/2" NPS	I, 2, 3, 4, L, C, E, F, A, R, S, T		
04	Black steel, 3/4" NPS	All except K, U, V	All	
05	Black steel, 1" NPS			
06	Welded steel, 1/8" NPS	n/a	n/a	I, 2, 3, 4, H, 5, 6
07	Welded steel, 1/4" NPS	n/a	I, 2, 3, 4, H, 5, 6	
08	Welded steel, 1" NPS	All except K, U, V	All	
09	Cast iron	I, 2, 3, 4, H, 5, 6, L, C, E, F, J, G, M	I, 2, 3, 4, H, 5, 6, L, C, E, F, J, G, M	
11	446 SS, 3/4" NPS	All except K, U, V	All except A, R, S, T	
12	446 SS, 1/2" NPS	I, 2, 3, 4, L, C, E, F, A, R, S, T		
13	446 SS, 1" NPS	All except K, U, V		
14	Pure nickel, 1/2" NPS	I, 2, 3, 4, L, C, E, F		
15	Pure nickel, 3/4" NPS	I, 2, 3, 4, H, 5, 6, L, C, E, F, J, G, M		
16	Inconel 601, 1/2" NPS	I, 2, 3, 4, L, C, E, F, A, R, S, T		
17	Inconel 601, 3/4" NPS	All except K, U, V		
18	304 SS, 1/4" NPS	n/a	I, 2, 3, 4, H, 5, 6, L, C, E, F, J, G, M	
19	304 SS, 1/2" NPS	I, 2, 3, 4, L, C, E, F, A, R, S, T	All	
21	Silicon carbide, 1-3/4" o.d.	I, 2, 3, 4, H, 5, 6, L, C, E, F	I, 2, 3, 4, H, 5, 6	
22	Silicon carbide w/collar	I, 2, 3, 4, H, 5, 6	n/a	I, 2, 3, 4, H, 5, 6, L, C, E, F, J, G, M
23	H.T. Mullite, 3/8" o.d.	n/a	I, 4	I, 4, H, 5, 6
24	H.T. Mullite, 11/16" o.d.	I, 4, L, F	I, 4, H, 5, 6, L, F, J, G, M	
25	H.T. Mullite, 1" o.d.	I, 4, H, 5, 6, L, F, J, G, M		
26	Incoloy 800, 1/2" NPS	I, 2, 3, 4, L, C, E, F, A, R, S, T	I, 2, 3, 4, H, 5, 6, L, C, E, F, J, G, M	
27	Incoloy 800, 3/4" NPS	I, 2, 3, 4, H, 5, 6, L, C, E, F, J, G, M		
28	Metal ceramic, 7/8" o.d.	I, L, F		
29	Aluminum oxide, 3/8" o.d.	n/a	I, 4	I, 4, H, 5, 6
30	Aluminum oxide, 11/16" o.d.	I, 4, L, F	I, 4, H, 5, 6, L, F, J, G, M	
31	Aluminum oxide, 1" o.d.	I, 4, H, 5, 6, L, F, J, G, M		
41	Ceramic clad	I, 2, 3, 4, L, C, E, F	I, 2, 3, 4, H, 5, 6, L, C, E, F, J, G, M	
42	Ceramic clad w/spring			
44	316 SS, 1/2" NPS	I, 2, 3, 4, L, C, E, F, A, R, S, T	All	
46	Silicon carbide pipe, reinforced	I, 2, 3, 4, L, C, E, F	I, 2, 3, 4, H, 5, 6, L, C, E, F, J, G, M	
47	316 SS, 3/4" NPS	All except K, U, V	All	
65	304 SS, 0.160" x 0.185"	n/a	n/a	I
66	304 SS, 0.194" x 0.250"			
67	304 SS, 0.305" x 0.375"	n/a	I, 4	I, 2, 3, 4, H, 5, 6
68	316 SS, 0.160" x 0.185"	n/a	n/a	I, 4
69	316 SS, 0.194" x 0.250"			
70	316 SS, 0.305" x 0.375"	n/a	I	I, 2, 3, 4, H, 5, 6
72	Inconel 601, 0.194" x 0.250	n/a	n/a	I
73	Inconel 601, 0.305" x 0.375"	n/a	I	I, 2, 3, 4, H, 5, 6

# T/C, Straight Metal or Ceramic

## Thermocouple, Metal or Ceramic Tube, Straight

### Introduction

Base metal thermocouple assemblies are designed to be used in the most severe and demanding environments. The choice of a specific style is to a large degree determined by the temperature working range, ambient atmospheric or media conditions, as well as the size and shape required for the application. Control requirements such as accuracy and speed of response may also be considerations.

When speed of response is critical, specify the open end construction. An exposed element is directly subject to corrosion and physical damage; therefore, this style should be used only after consideration of the relative need for fast response versus thermocouple life.

Another feature for improving response time is the butt welded junction. This design has less mass and therefore faster response than the twist, which is normally supplied by the factory. The twist weld offers greater mechanical strength and longer life.

When possible, the sensor should be installed in a vertical plane rather than horizontal to prevent sagging.

### Ordering Information

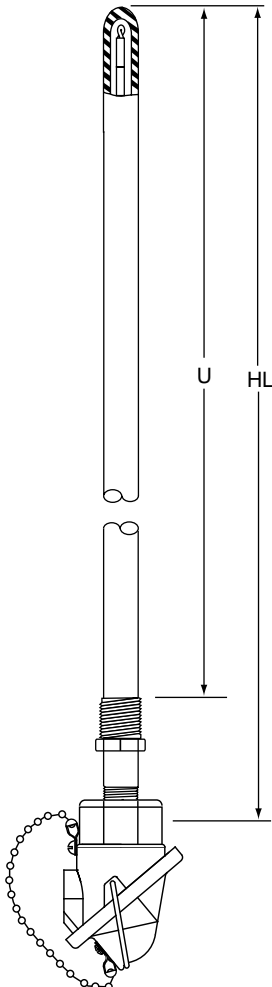

**Model No.**     -       -  **0**   -

Field No.      1    2    3    4    5    6    7    8    9    10 11 12    13    14    15

#### Fields 1, 2, 3. THERMOCOUPLE TYPE; WIRE GAUGE

Determine length by completing Fields 8, 9

	Type	Wire	Gauge	Limits
J08 -	J	Iron-Constantan	8	standard
J09 -	J	Iron-Constantan	8	special
J14 -	J	Iron-Constantan	14	standard
J15 -	J	Iron-Constantan	14	special
J20 -	J	Iron-Constantan	20	standard
J21 -	J	Iron-Constantan	20	special
K08 -	K	Chromel-Alumel	8	standard
K09 -	K	Chromel-Alumel	8	special
K14 -	K	Chromel-Alumel	14	standard
K15 -	K	Chromel-Alumel	14	special
K20 -	K	Chromel-Alumel	20	standard
K21 -	K	Chromel-Alumel	20	special
E08 -	E	Chromel-Constantan	8	standard
E09 -	E	Chromel-Constantan	8	special
E14 -	E	Chromel-Constantan	14	standard
E15 -	E	Chromel-Constantan	14	special
E20 -	E	Chromel-Constantan	20	standard
E21 -	E	Chromel-Constantan	20	special
T14 -	T	Copper-Constantan	14	standard
T15 -	T	Copper-Constantan	14	special
T20 -	T	Copper-Constantan	20	standard
T21 -	T	Copper-Constantan	20	special

\*Ni 0.8% Co - Ni 18% Mo14    standard    Special order, consult factory

# T/C, Straight Metal or Ceramic

## Ordering Information (continued)

### Field 4. NUMBER OF ELEMENTS AND JUNCTION STYLE

Note: this is the letter "I,"  
not the numeral "1."

- 1 - Single, twisted, grounded
- 2 - Single, twisted, ungrounded
- 3 - Single, butt welded, grounded
- 4 - Single, butt welded, ungrounded
- H - Dual, twisted, grounded
- 5 - Dual common, butt welded, ungrounded
- 6 - Dual isolated, butt welded, ungrounded

### Fields 5, 6. PROTECTION TUBE

 Use length determined in Fields 8, 9. See compatibility table on page 3-3.

Size	Material
<b>Metal</b>	
02 - 1/4" NPT	Low carbon black steel
03 - 1/2" NPT	Low carbon black steel
04 - 3/4" NPT	Low carbon black steel
05 - 1" XH NPT	Low carbon black steel, extra heavy wall, schedule 80 pipe
06 - 1/8" NPT	SAE 1020 steel
07 - 1/4" NPT	SAE 1026 steel
08 - 1" XH NPT	SAE 1025 steel, extra heavy wall, schedule 80 pipe
11 - 3/4" NPT	446 stainless steel
12 - 1/2" NPT	446 stainless steel
13 - 1" NPT	446 stainless steel
14 - 1/2" NPT	Nickel
16 - 1/2" NPT	Inconel 601
17 - 3/4" NPT	Inconel 601
18 - 1/4" NPT	304 stainless steel
19 - 1/2" NPT	304 stainless steel
26 - 1/2" NPT	Incoloy 800, (Obsolete)
27 - 3/4" NPT	Incoloy 800, (Obsolete)
44 - 1/2" NPT	316 stainless steel
47 - 3/4" NPT	316 stainless steel
<b>Ceramic Tube</b>	
21 - 1-3/4" o.d.	Silicon carbide (note 3)
22 - 1-3/4" o.d.	Silicon carbide with collar (note 3)
23 - 3/8" o.d.	High temperature Mullite
24 - 11/16" o.d.	High temperature Mullite
25 - 1" o.d.	High temperature Mullite
28 - 7/8" o.d.	Metal ceramic (note 3)
29 - 3/8" o.d.	Aluminum oxide
30 - 11/16" o.d.	Aluminum oxide
31 - 1" o.d.	Aluminum oxide
34 - 7 mm o.d.	Aluminum oxide
<b>Other</b>	
09 - 1-5/8" o.d.	Cast iron
41 - 1-1/4" o.d.	Steel, ceramic coated (notes 1 & 3)
42 - 1-1/4" o.d.	Steel, ceramic coated, with spring (notes 2 & 3)

#### Notes:

- 1) Immersion depth is 2" less than hot length. Replacement element is A-11711.
- 2) Immersion depth is 8" less than hot length. Minimum length is 18". Replacement element is A-11888.
- 3) Available only in increments of 6".

### Field 7. COLD END TERMINATION

- 1 -General purpose, cast iron, Obsolete use code "2"
- 2 - Weatherproof, cast iron
- 3 -General purpose, aluminum, Obsolete use code "A"
- A - Weatherproof, aluminum
- B - Explosionproof (n/a with ceramic tube)
- D - Aluminum, DIN size
- E - Aluminum, explosionproof (extended lead timen/a with ceramic tube)

See page 3-30 for protection tube/cold end termination compatibility table.

# T/C, Straight Metal or Ceramic

## Ordering Information (continued)

### Fields 8, 9. HOT LENGTH (DIMENSION "HL")

- ☞ Complete these Fields to determine length for Fields 1, 2, 3. and Fields 5, 6  
HL - Enter actual inches in 6" increments. Minimum 12", maximum 48"  
(except if Fields 5, 6 is code 42, 18" minimum)  
HL - Over 48" consult factory for availability.  
99 - Metric. Specify dimension on order.

### Field 10. HOT END

- 0 - Closed end  
8 - Open end

### Fields 11, 12. RESERVED

### Field 13. MOUNTING FITTING

#### Either Metal Pipe or Ceramic Tube

- 0 - None (Required when Fields 5, 6 is code 01, 09, 41 or 42)  
2 - Adjustable flange

#### Metal Pipe (must specify at least 1 size larger than Pipe - Fields 5, 6)

- 8 - Welded bushing, black steel, one size larger than pipe (standard)  
A - 1/2" welded bushing, black steel  
B - 3/4" welded bushing, black steel  
C - 1" welded bushing, black steel  
D - 1-1/2" welded bushing, black steel  
M - 1-1/4" welded bushing, black steel  
E - 1/2" welded bushing, 316 stainless steel  
F - 3/4" welded bushing, 316 stainless steel  
G - 1" welded bushing, 316 stainless steel  
N - 1-1/4" welded bushing, 316 stainless steel  
H - 1-1/2" welded bushing, 316 stainless steel

#### Fittings for Metal Pipe Protection Tubes

Pipe Size	Available Fitting Codes
1/8" NPT	0, 2, 8, A, B, C, E, F, & G
1/4" NPT	0, 2, 8, A, B, C, E, F, & G
1/2" NPT	0, 2, 8, B, C, D, F, G, H, M & N
3/4" NPT	0, 2, 8, D, G, H, M & N
1" NPT	0, 2, 8, D, H, M & N

#### Ceramic Tube

- 1 - 4" Black steel sleeve\*  
3 - 4" Stainless steel sleeve\*  
4 - 4" Stainless steel sleeve and flange\*  
5 - 4" Black steel sleeve and flange\*  
7 - Double ended bushing\*  
P - Double ended bushing, 1/2" x 3/4" (Fields 5, 6, codes 24 and 30 only)  
R - Black steel sleeve longer than 4". Specify length in order.\*  
T - Stainless steel sleeve longer than 4". Specify length in order.\*  
V - Stainless steel sleeve and flange longer than 4". Specify length in order.\*  
W - Black steel sleeve and flange longer than 4". Specify length in order.\*  
\*Cannot be used with Fields 5, 6, code 21.

### Fields 14, 15. MOUNTING FITTING LOCATION ("U" DIMENSION)

- Applicable only for welded bushing fitting in Field 13  
UU -Whole inches  
99 - Fractional inches or metric; specify details on order.  
The maximum "U" dimension is the Hot Length minus two inches.

# T/C, 90° Metal or Ceramic

## Thermocouple, Metal or Ceramic Tube, 90° Elbow

### Introduction

Base metal thermocouple assemblies are designed to be used in the most severe and demanding environments. The choice of a specific style is to a large degree determined by the temperature working range, ambient atmospheric or media conditions, as well as the size and shape required for the application. Control requirements such as accuracy and speed of response may also be considerations.

When speed of response is critical, specify the open end construction. An exposed element is directly subject to corrosion and physical damage; therefore, this style should be used only after consideration of the relative need for fast response versus thermocouple life.

Another feature for improving response time is the butt welded junction. This design has less mass and therefore faster response than the twist, which is normally supplied by the factory. The twist weld offers greater mechanical strength and longer life.

### Ordering Information

**Model No.**     -      -     -   - 0 0  
 Field No. 1 2 3 4 5 6 7 8 9 10 11 12 13 14 15

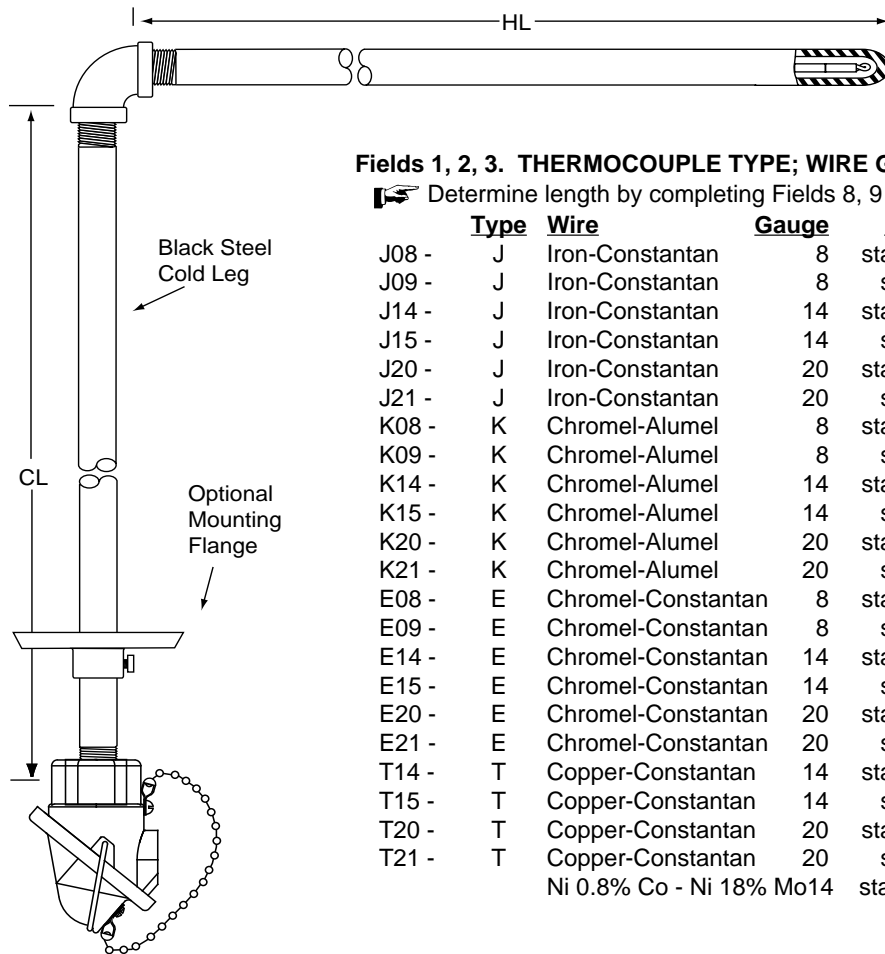

#### Fields 1, 2, 3. THERMOCOUPLE TYPE; WIRE GAUGE

☞ Determine length by completing Fields 8, 9 and Fields 11, 12; then add together.

Type	Wire	Gauge	Limits
J08 -	J Iron-Constantan	8	standard
J09 -	J Iron-Constantan	8	special
J14 -	J Iron-Constantan	14	standard
J15 -	J Iron-Constantan	14	special
J20 -	J Iron-Constantan	20	standard
J21 -	J Iron-Constantan	20	special
K08 -	K Chromel-Alumel	8	standard
K09 -	K Chromel-Alumel	8	special
K14 -	K Chromel-Alumel	14	standard
K15 -	K Chromel-Alumel	14	special
K20 -	K Chromel-Alumel	20	standard
K21 -	K Chromel-Alumel	20	special
E08 -	E Chromel-Constantan	8	standard
E09 -	E Chromel-Constantan	8	special
E14 -	E Chromel-Constantan	14	standard
E15 -	E Chromel-Constantan	14	special
E20 -	E Chromel-Constantan	20	standard
E21 -	E Chromel-Constantan	20	special
T14 -	T Copper-Constantan	14	standard
T15 -	T Copper-Constantan	14	special
T20 -	T Copper-Constantan	20	standard
T21 -	T Copper-Constantan	20	special
	Ni 0.8% Co - Ni 18% Mo14		standard Special order, consult factory

# T/C, 90° Metal or Ceramic

## Ordering Information (continued)

### Field 4. NUMBER OF ELEMENTS AND JUNCTION STYLE

- L - Single, twisted, grounded
- C - Single, twisted, ungrounded
- E - Single, butt welded, grounded
- F - Single, butt welded, ungrounded
- J - Dual, twisted, grounded
- G - Dual common, butt welded, ungrounded
- M - Dual isolated, butt welded, ungrounded
- D - Reserved. Do not use when ordering new thermocouple.

### Fields 5, 6. PROTECTION TUBE (HOT LENGTH ONLY)

☞ Determine length by completing Fields 8, 9.

See compatibility table on page 3-3.

	<u>Size</u>	<u>Material</u>
<b><u>Metal Pipe</u></b>		
02 -	1/4"	NPT Low carbon black steel
03 -	1/2"	NPT Low carbon black steel
04 -	3/4"	NPT Low carbon black steel
05 -	1" XH	NPT Low carbon black steel, extra heavy wall, schedule 80 pipe
08 -	1" XH	NPT SAE 1025 steel, extra heavy wall, schedule 80 pipe
11 -	3/4"	NPT 446 stainless steel
12 -	1/2"	NPT 446 stainless steel
13 -	1"	NPT 446 stainless steel
14 -	1/2"	NPT Nickel
16 -	1/2"	NPT Inconel 601
17 -	3/4"	NPT Inconel 601
18 -	1/4"	NPT 304 stainless steel
19 -	1/2"	NPT 304 stainless steel
26 -	1/2"	NPT Incoloy 800 (Obsolete)
27 -	3/4"	NPT Incoloy 800 (Obsolete)
44 -	1/2"	NPT 316 stainless steel
47 -	3/4"	NPT 316 stainless steel
<b><u>Ceramic Tube</u></b>		
21 -	1-3/4" o.d.	Silicon carbide (note 3)
24 -	11/16" o.d.	High temperature Mullite
25 -	1" o.d.	High temperature Mullite
28 -	7/8" o.d.	Metal ceramic (note 3)
30 -	11/16" o.d.	Aluminum oxide
31 -	1" o.d.	Aluminum oxide
<b><u>Other</u></b>		
09 -	1-5/8" o.d.	Cast iron
41 -	1-1/4" o.d.	Ceramic coated steel (notes 1 & 3)
42 -	1-1/4" o.d.	Ceramic coated steel with spring (notes 2 & 3)
46 -	1-3/4" o.d.	Silicon carbide, 1/2" pipe reinforced (note 3)

#### Notes:

- 1) Immersion depth is 2" less than hot length. Replacement element is A-11711.
- 2) Immersion depth is 8" less than hot length. Minimum length is 18". Replacement element is A-11888.
- 3) Available only in increments of 6".

# T/C, 90° Metal or Ceramic

## Ordering Information (continued)

### Field 7. COLD END TERMINATION

See page 3-30 for protection tube/cold end termination compatibility table.

- 1 - General purpose, cast iron, Obsolete use code "2"
- 2 - Weatherproof, cast iron
- 3 - General purpose, aluminum, Obsolete use code "A"
- A - Weatherproof, aluminum
- B - Explosionproof (n/a with ceramic tube)
- D - Aluminum, DIN size
- E - Aluminum, explosionproof (extended lead time, n/a with ceramic tube)

### Fields 8, 9. HOT LENGTH (DIMENSION "HL")

 Complete these Fields to determine lengths for Fields 1, 2, 3, and Fields 5, 6

HL - Enter actual inches in 6" increments. Minimum 12", maximum 48"  
except if Fields 5, 6 is code 42, minimum length 18"

HL - Over 48" consult factory for availability.

### Field 10. HOT END

- 0 - Closed end metal pipe
- 8 - Open end metal pipe (See Fields 5, 6)
- 9 - Open end ceramic tube (See Fields 5, 6)  
(Ceramic tube is 1" shorter than specified "HL" dimension)

### Fields 11, 12. COLD LEG (DIMENSION "CL")

 Complete these Fields to determine lengths for Fields 1, 2, 3

CL - Black steel. Enter actual inches in multiples of 6"

### Field 13. MOUNTING FITTINGS

- 0 - None (Required when Fields 5, 6 is code 01, 09, 41 or 42)
- 2 - Adjustable flange

### Fields 14, 15. RESERVED

# T/C, 90° Metal

## Thermocouple, Metal Pipe, 90° Bend

### Introduction

This sensor offers the same functionality and features as the 90° elbow style described on the previous page, except it is not offered with a ceramic tube or a nickel tube.

### Ordering Information

Model No.     -      -    -   - 0 0  
 Field No. 1 2 3 4 5 6 7 8 9 10 11 12 13 14 15

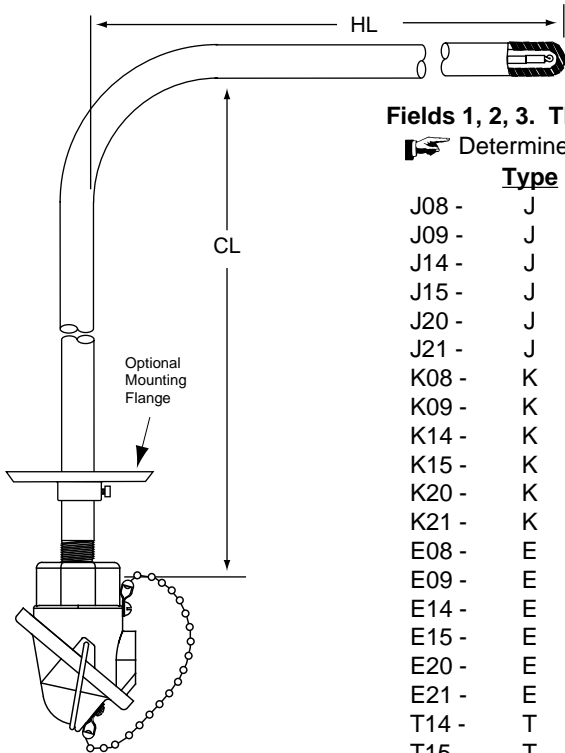

#### Fields 1, 2, 3. THERMOCOUPLE TYPE; WIRE GAUGE

☞ Determine length by completing Fields 8, 9 and Fields 11, 12; then add together.

	Type	Wire	Gauge	Limits
J08 -	J	Iron-Constantan	8	standard
J09 -	J	Iron-Constantan	8	special
J14 -	J	Iron-Constantan	14	standard
J15 -	J	Iron-Constantan	14	special
J20 -	J	Iron-Constantan	20	standard
J21 -	J	Iron-Constantan	20	special
K08 -	K	Chromel-Alumel	8	standard
K09 -	K	Chromel-Alumel	8	special
K14 -	K	Chromel-Alumel	14	standard
K15 -	K	Chromel-Alumel	14	special
K20 -	K	Chromel-Alumel	20	standard
K21 -	K	Chromel-Alumel	20	special
E08 -	E	Chromel-Constantan	8	standard
E09 -	E	Chromel-Constantan	8	special
E14 -	E	Chromel-Constantan	14	standard
E15 -	E	Chromel-Constantan	14	special
E20 -	E	Chromel-Constantan	20	standard
E21 -	E	Chromel-Constantan	20	special
T14 -	T	Copper-Constantan	14	standard
T15 -	T	Copper-Constantan	14	special
T20 -	T	Copper-Constantan	20	standard
T21 -	T	Copper-Constantan	20	special

#### Field 4. NUMBER OF ELEMENTS AND JUNCTION STYLE

- A - Single, twisted, grounded
- R - Single, twisted, ungrounded
- S - Single, butt welded, grounded
- T - Single, butt welded, ungrounded
- K - Dual, twisted, grounded
- U - Dual common, butt welded, ungrounded
- V - Dual isolated, butt welded, ungrounded
- D - Reserved. Do not use when ordering new thermocouple.

#### Fields 5, 6. PROTECTION TUBE

☞ Use length determined in Fields 8, 9 and Fields 11, 12.

# T/C, 90° Metal

## Ordering Information (continued)

See compatability table on page 3-3.

<b>Size</b>	<b>Material</b>
02 - 1/4"	NPT Low carbon black steel
03 - 1/2"	NPT Low carbon black steel
04 - 3/4"	NPT Low carbon black steel
05 - 1" XH*	NPT Low carbon black steel, extra heavy wall, schedule 80 pipe
07 - 1/4"	NPT SAE 1026 steel
08 - 1" XH	NPT SAE 1025 steel
11 - 3/4"	NPT 446 stainless steel
12 - 1/2"	NPT 446 stainless steel
13 - 1"	NPT 446 stainless steel
16 - 1/2"	NPT Inconel 601
17 - 3/4"	NPT Inconel 601
18 - 1/4"	NPT 304 stainless steel
19 - 1/2"	NPT 304 stainless steel
26 - 1/2"	NPT Incoloy 800 (Obsolete)
27 - 3/4"	NPT Incoloy 800 (Obsolete)
44 - 1/2"	NPT 316 stainless steel
47 - 3/4"	NPT 316 stainless steel

### Field 7. COLD END TERMINATION

See page 3-30 for protection tube/cold end termination compatibility table.

- 1 - General purpose, cast iron, Obolete use code "2"
- 2 - Weatherproof, cast iron
- 3 - General purpose, aluminum. Obsolete usw code "A"
- A - Weatherproof, aluminum
- B - Explosionproof
- D - Aluminum, DIN size
- E - Aluminum, explosionproof (extended lead time)

### Fields 8, 9. HOT LENGTH (DIMENSION "HL")

-  Complete these Fields to determine length for Fields 1, 2, 3.
- HL - Enter actual inches in 6" increments. Minimum 12", maximum 48"
- HL - Over 48" consult factory for availability.

### Field 10. HOT END

- 0 - Closed end
- 8 - Open end

### Fields 11, 12. COLD LEG (DIMENSION "CL")

-  Complete these Fields to determine length for Fields 1, 2, 3.
- CL - Enter actual inches in multiples of 06".

### Field 13. MOUNTING FITTINGS

- 0 - None
- 2 - Adjustable flange

### Fields 14, 15. RESERVED

# T/C, Straight Metal

## Thermocouple, Metal (Thin Wall) Tube, Straight

### Introduction

Offers the same functionality and features as other industrial sensors described on previous pages, except will accommodate wire only down to 14 gauge.

For high performance and added flexibility, we suggest you consider our BARCOPAC® MgO insulated thermocouples illustrated in Section 4.

This thermocouple can be mounted to the process with compression attaching device.

### Ordering Information

Model No.     -      -  0 0 -  - 0 0  
 Field No. 1 2 3 4 5 6 7 8 9 10 11 12 13 14 15

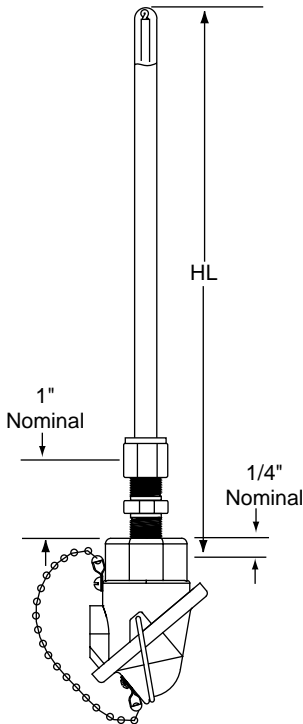

#### Fields 1, 2, 3. THERMOCOUPLE TYPE; WIRE GAUGE

☞ Determine length by completing Fields 8, 9

	Type	Wire	Gauge	Limits
J14 -	J	Iron-Constantan	14	standard
J15 -	J	Iron-Constantan	14	special
J20 -	J	Iron-Constantan	20	standard
J21 -	J	Iron-Constantan	20	special
K14 -	K	Chromel-Alumel	14	standard
K15 -	K	Chromel-Alumel	14	special
K20 -	K	Chromel-Alumel	20	standard
K21 -	K	Chromel-Alumel	20	special
E14 -	E	Chromel-Constantan	14	standard
E15 -	E	Chromel-Constantan	14	special
E20 -	E	Chromel-Constantan	20	standard
E21 -	E	Chromel-Constantan	20	special
T14 -	T	Copper-Constantan	14	standard
T15 -	T	Copper-Constantan	14	special
T20 -	T	Copper-Constantan	20	standard
T21 -	T	Copper-Constantan	20	special

#### Field 4. NUMBER OF ELEMENTS AND JUNCTION STYLE

- 1 - Single, twisted, grounded
- 2 - Single, twisted, ungrounded
- 3 - Single, butt welded, grounded
- 4 - Single, butt welded, ungrounded
- H - Dual, twisted, grounded
- 5 - Dual common, butt welded, ungrounded
- 6 - Dual isolated, butt welded, ungrounded

# T/C, Straight Metal

## Ordering Information (continued)

### Fields 5, 6. PROTECTION TUBE

 Use length determined in Fields 8, 9.  
See compatibility table on page 3-3.

	<u>Size</u>		<u>Material</u>
65 -	0.188" (3/16")	o.d.	304 stainless steel
66 -	0.250" (1/4")	o.d.	304 stainless steel
67 -	0.375" (3/8")*	o.d.	304 stainless steel
68 -	0.188" (3/16")	o.d.	316 stainless steel
69 -	0.250" (1/4")	o.d.	316 stainless steel
70 -	0.375" (3/8")*	o.d.	316 stainless steel
72 -	0.250" (1/4")	o.d.	Inconel
73 -	0.375" (3/8")*	o.d.	Inconel

\*not applicable if Field 7 is code 5, 6 or 8

### Field 7. COLD END TERMINATION

See page 3-30 for protection tube/cold end termination compatibility table.

- 1 - General purpose, cast iron, Obsolete use code "2"
- 2 - Weatherproof, cast iron
- 3 - General purpose, aluminum, Obsolete use code "A"
- 5 - Ceramic Wafer\*
- 6 - General purpose, miniature\*
- 8 - Weatherproof, plastic, miniature\*
- A - Weatherproof, aluminum
- B - Explosionproof
- D - Aluminum, DIN size
- E - Aluminum, explosionproof (extended lead time)

\*not available for 0.375" (3/8") tubes, or dual element assemblies

### Fields 8, 9. HOT LENGTH (DIMENSION "HL")

 Complete these Fields to determine lengths for Fields 1, 2, 3 and Fields 5, 6.

- HL - Enter actual inches in 6" increments. Minimum 12", maximum 48"
- HL - Over 48"

### Field 10. HOT END

- 0 - Closed end
- 8 - Open end

### Fields 11, 12. RESERVED

### Field 13. MOUNTING FITTINGS

- 0 - None
- 7 - Double ended bushing, 1/2" NPT

### Fields 14, 15. RESERVED

# T/C, Noble, Straight Ceramic

## Thermocouple, Noble Metal Ceramic Tube, Straight

### Introduction

Elements are constructed of high quality material using modern techniques to construct the hot junction. Other high quality components are designed to meet rugged requirements. Mullite protection pipes (Field 5, codes 23, 24, 25) are impervious to gases at high temperature. They have good resistance to thermal shock but poor resistance to mechanical shock; they should be mounted vertically.

Aluminum oxide protection tubes (Field 5, codes 29, 30, 31 and 34) have fair resistance to thermal shock and mechanical shock. They are impervious to gases up to 3200°F.

### Applications

Primary metal industry, heat treat furnaces, forging furnaces and bright annealing. Suitable for ceramics and glass industries. Semi-conductor manufacturing and research laboratories.

### Ordering Information

**Model No.**     -       - 0  0 -  - 0 0  
 Field No. 1 2 3 4 5 6 7 8 9 10 11 12 13 14 15

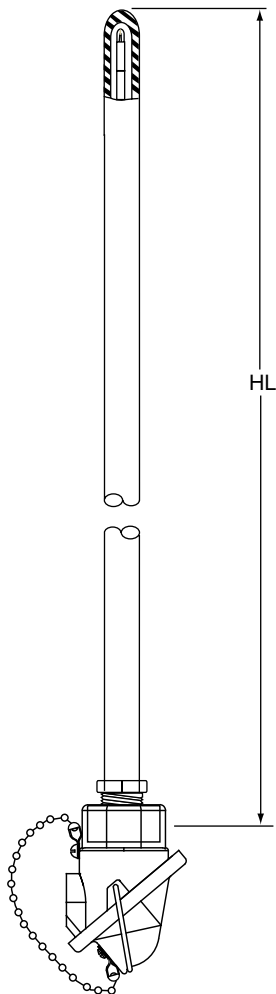

#### Fields 1, 2, 3. THERMOCOUPLE TYPE; WIRE GAUGE

☞ Determine length by completing Fields 8, 9

	Type	Wire	Gauge	Limits
B24 -	B	Pt, 6% Rh v Pt, 30% Rh	24	standard
B25 -	B	Pt, 6% Rh v Pt, 30% Rh	25	special
R24 -	R	Pt v Pt, 13% Rh	24	standard
R25 -	R	Pt v Pt, 13% Rh	25	special
S24 -	S	Pt v Pt, 10% Rh	24	standard
S25 -	S	Pt v Pt, 10% Rh	25	special
C24 -	C	W, 5% Re v W, 26% Re	24	standard

#### Field 4. NUMBER OF ELEMENTS AND JUNCTION STYLE

- I - Single, butt welded, ungrounded
- H - Dual, butt welded, ungrounded

#### Fields 5, 6. PROTECTION TUBE

☞ Use length determined for Fields 1, 2, 3. See compatibility table after Field 7.

	Size	Material
23 -	3/8" o.d.	High temperature Mullite
24 -	11/16" o.d.	High temperature Mullite
25 -	1" NPT	High temperature Mullite
29 -	3/8" NPT	Aluminum oxide
30 -	11/16" NPT	Aluminum oxide
31 -	1" NPT	Aluminum oxide
34 -	7 mm NPT	Aluminum oxide

#### Field 7. COLD END TERMINATION

# T/C, Noble, Straight Ceramic

## Ordering Information (continued)

See page 3-30 for protection tube/cold end termination compatibility table.

- 1 - General purpose, cast iron, Obsolete use code "2"
- 2 - Weatherproof, cast iron
- 3 - General purpose, aluminum, Obsolete use code "A"
- 7 - Quick disconnect plug
- 8 - Weatherproof, plastic
- 9 - Brass, open, no external process mount threads
- A - Weatherproof, aluminum
- C - Brass, open, with external process mount threads
- D - Aluminum, DIN size

Compatibility Table							
Blank cell = compatible; filled cell = not compatible							
Fields 5, 6	Field 7						
	1	2	3	7	8	9	A
23							
24, 25, 30, 31							
29							
34							

### Fields 8, 9. HOT LENGTH (DIMENSION "HL")

- ☞ Complete these fields to determine lengths for Fields 1, 2, 3, and Fields 5, 6.
- HL - Enter actual inches in 6" increments. Minimum 12", maximum 48"  
Over 48" consult factory for availability.

### Field 10. RESERVED

### Field 11. TUBE SEAL

- 0 - None – not available with Fields 1, 2, 3, code C24
- 1 - Sealed and filled with inert gas

### Field 12. RESERVED

### Field 13. MOUNTING FITTING\*

- 0 - None (Required when Field 5, 6 is code 01, 09, 41 or 42)
- 1 - 4" Black steel sleeve
- 3 - 4" Stainless steel sleeve
- 4 - 4" Stainless steel sleeve and flange
- 5 - 4" Black steel sleeve and flange
- 7 - Double ended bushing
- P - Double ended bushing, 1/2" x 3/4" NPT (Fields 5, 6, codes 23, 24, 29 & 30 only)
- 8 - Compression fitting (Fields 5, 6, code 34 only)
- R - Black steel sleeve longer than 4". Specify length in order.\*
- T - Stainless steel sleeve longer than 4". Specify length in order.\*
- V - Stainless steel sleeve and flange longer than 4". Specify length in order.\*
- W - Black steel sleeve and flange longer than 4". Specify length in order.\*

\* Mounting Fitting NPT Sizes (except as noted for code "P")

- Field 5, 6 codes 23, 29, 34 ..... 1/2"
- Field 5, 6 codes 24, 30 ..... 3/4"
- Field 5, 6 codes 25, 31 ..... 1"

### Fields 14, 15. RESERVED



# T/C, Noble, Dual, Straight

## Ordering Information (continued)

See page 3-30 for protection tube/cold end termination compatibility table.

- 1 - General purpose, cast iron, Obsolete use code "2"
- 2 - Weatherproof, cast iron
- 3 - General purpose, aluminum, Obsolete use code "A"
- 9 - Brass, open, no external process mount threads
- A - Weatherproof, aluminum
- C - Brass, open, with external process mount threads
- D - Aluminum, DIN size

### Fields 8, 9. HOT LENGTH (DIMENSION "HL")

-  Complete these Fields to determine lengths for Fields 1, 2, 3 and Fields 5, 6
- HL- Enter actual inches. Minimum 12", maximum 48"  
Over 48" consult factory for availability

### Field 10. RESERVED

### Field 11. TUBE SEAL

- 0 - None – not available with Fields 1, 2, 3, code C24
- 1 - Sealed and filled with inert gas

### Field 12. RESERVED

### Field 13. MOUNTING FITTING\*

- 0 - None (Required when Field 5, 6 is code 01, 09, 41 or 42)
- 1 - 4" Black steel sleeve
- 3 - 4" Stainless steel sleeve
- 4 - 4" Stainless steel sleeve and flange
- 5 - 4" Black steel sleeve and flange
- 7 - Double ended bushing
- P - Double ended bushing, 1/2" x 3/4" (Fields 5, 6, codes 23 and 29 only)
- 9 - Sleeve longer than 4". Specify length on order;
- R - Black steel sleeve longer than 4". Specify length in order.\*
- T - Stainless steel sleeve longer than 4". Specify length in order.\*
- V - Stainless steel sleeve and flange longer than 4". Specify length in order.\*
- W - Black steel sleeve and flange longer than 4". Specify length in order.\*

\*Mounting Fitting NPT Sizes (except as noted for code "P")

- Tube codes 23, 29, 34 ..... 1/2"
- Tube codes 24, 30 ..... 3/4"
- Tube codes 25, 31 ..... 1"

### Fields 14, 15. RESERVED

# T/C, Noble, Dual, Straight

## Thermocouple, Noble Metal Dual Tube (Ceramic in Inconel 601), Straight

### Introduction

Elements are made of top quality material. Insulators are 99.7% Al<sub>2</sub>O<sub>3</sub> (high purity). Primary protection tube is either high temperature Mullite or aluminum oxide. The secondary protection tube is Inconel 601 which has a high resistance to thermal and mechanical shock up to 2300°F. The Inconel 601 protection tube has excellent resistance to oxidation up to 2300°F and to corrosion at high temperature. Hydrogen makes it brittle.

3/8" o.d. primary tube is inside an 0.8450" o.d. pipe; 11/16" o.d. tube is inside a 1.050" o.d. pipe.

### Applications

For use in furnaces, kilns, and other locations where the protection tube is subject to either mechanical or thermal shock. Suitable for high temperature heat treating, carburizing, nitriding, salt baths, blast furnace operation, gas generators, and ceramic kilns.

### Ordering Information

Model No.     -       - 6  0 -  -    
Field No. 1 2 3 4 5 6 7 8 9 10 11 12 13 14 15

#### Fields 1, 2, 3. THERMOCOUPLE TYPE; WIRE GAUGE

☞ Determine length by completing Fields 8, 9

Type	Wire	Gauge	Limits
B24 -	B Pt, 6% Rh v Pt, 30% Rh	24	standard
B25 -	B Pt, 6% Rh v Pt, 30% Rh	25	special
R24 -	R Pt v Pt, 13% Rh	24	standard
R25 -	R Pt v Pt, 13% Rh	25	special
S24 -	S Pt v Pt, 10% Rh	24	standard
S25 -	S Pt v Pt, 10% Rh	25	special
C24 -	C W, 5% Re v W, 26% Re	24	standard

#### Field 4. NUMBER OF ELEMENTS AND JUNCTION STYLE

- I - Single, butt welded, ungrounded
- H - Dual, butt welded, ungrounded

#### Fields 5, 6. PROTECTION TUBES

☞ Use length determined in Fields 8, 9

##### Primary Tube

Size	Material
23 - 3/8"	High temperature Mullite
24 - 11/16"	High temperature Mullite
29 - 3/8"	Aluminum oxide
30 - 11/16"	Aluminum oxide

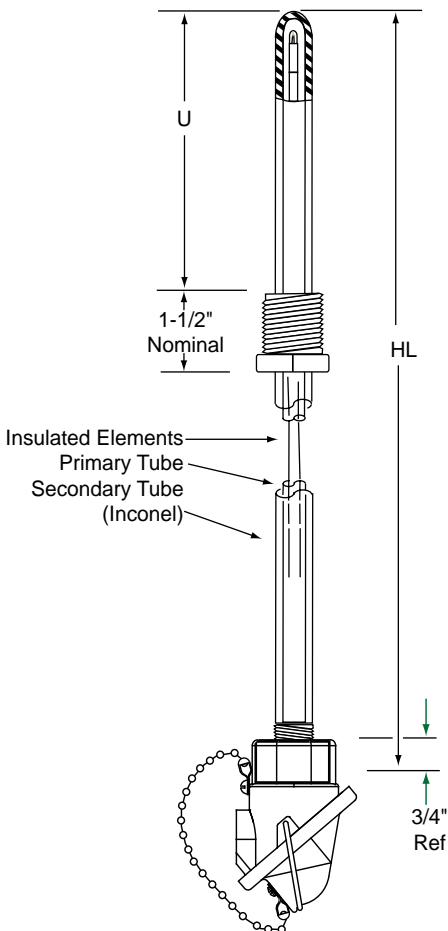

# T/C, Noble, Dual, Straight

## Ordering Information (continued)

### Field 7. COLD END TERMINATION

See page 3-30 for protection tube/cold end termination compatibility table.

- 1 - General purpose, cast iron, Obsolete use code "2"
- 2 - Weatherproof, cast iron
- 3 - General purpose, aluminum, Obsolete use code "A"
- 9 - Brass, open, no external process mount threads
- A - Weatherproof, aluminum
- B - Explosionproof, cast iron
- C - Brass, open, with external process mount threads
- D - Aluminum, DIN size
- E - Explosionproof, aluminum (extended lead time)

### Fields 8, 9. HOT LENGTH (DIMENSION "HL")

 Complete these Fields to determine lengths for Fields 1, 2, 3 and Fields 5, 6

- HL - Enter actual inches. Minimum 12", maximum 48". Over 48" consult factory  
When "U" dimension (Fields 14, 15) is specified,  
allow for 1-1/2" nominal bushing length.

### Field 10. RESERVED

### Field 11. TUBE SEAL

- 0 - None
- 1 - Sealed and filled with inert gas

### Field 12. RESERVED

### Field 13. MOUNTING FITTING

- 0 - None
- 2 - Adjustable mounting flange
- F - Welded bushing, 3/4" NPT, SS (Fields 5, 6, codes 23 and 29 only)
- G - Welded bushing, 1" NPT, SS (Fields 5, 6, codes 24 and 30 only)

### Fields 14, 15. MOUNTING FITTING LOCATION ("U" DIMENSION)

Applicable only if Field 13 is code F or G.

- 00 - Not applicable
- UU - Whole inches
- 99 - Fractional inches, specify on order

# T/C, Noble, Dual or Triple, Straight

## Thermocouple, Noble Metal Dual or Triple Tube (Ceramic in Silicon Carbide), Straight

### Introduction

The design of this assembly is for the maximum protection of the noble metal element. The primary protection tube (or tubes) protects the element from outside gases while the outer tube of silicon carbide protects the assembly against the cutting action of flames and hot gases. You can choose either high temperature Mullite or aluminum oxide for the primary tube material. High temperature Mullite is not recommended for temperatures above 1800°F.

Silicon carbide protection tubes have low lag time and long life; high resistance to thermal shock, high conductivity, and impermeability. They are especially resistant to many corrosive atmospheres and are highly resistant to attack by many molten nonferrous metals.

### Applications

For use with molten nonferrous metals, brick kilns, ceramic kilns and where the thermocouple is exposed to either flames or hot gases.

### Ordering Information

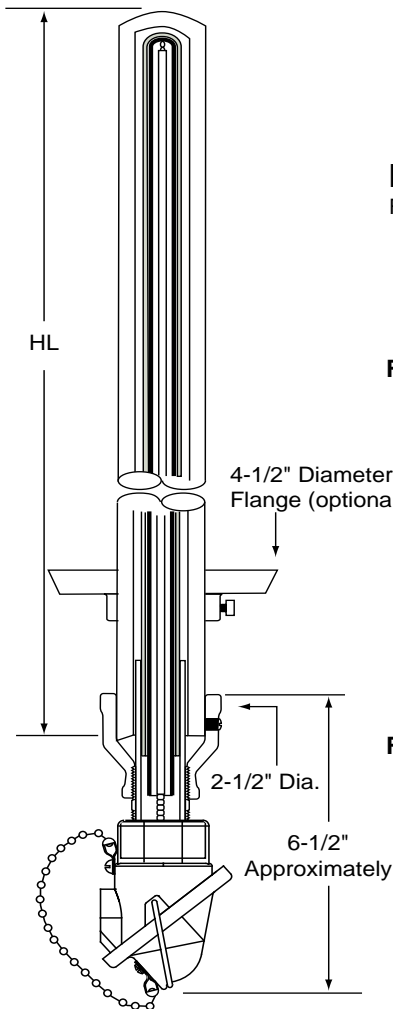

**Model No.**     -       -   **0** -   **00**  
 Field No.      1    2    3    4    5    6    7    8    9    10 11 12 13 14 15

### Fields 1, 2, 3. THERMOCOUPLE TYPE; WIRE GAUGE

Determine length by completing Fields 8, 9

	Type	Wire	Gauge	Limits
B24 -	B	Pt, 6% Rh v Pt, 30% Rh	24	standard
B25 -	B	Pt, 6% Rh v Pt, 30% Rh	25	special
B26 -	B	Pt, 6% Rh v Pt, 30% Rh	26	standard
R24 -	R	Pt v Pt, 13% Rh	24	standard
R25 -	R	Pt v Pt, 13% Rh	25	special
R26 -	R	Pt v Pt, 13% Rh	26	standard
S24 -	S	Pt v Pt, 10% Rh	24	standard
S25 -	S	Pt v Pt, 10% Rh	25	special
S26 -	S	Pt v Pt, 10% Rh	26	standard

### Field 4. NUMBER OF ELEMENTS AND JUNCTION STYLE

- I - Single, butt welded, ungrounded
- H - Dual, butt welded, ungrounded

# T/C, Noble, Dual or Triple, Straight

## Ordering Information (continued)

### Fields 5, 6. PROTECTION TUBES

 Use length determined in Fields 8, 9

Size	Material
------	----------

#### Dual Tube Assemblies (Primary tube is 11/16")

24 - 11/16" High temperature Mullite

30 - 11/16" Aluminum oxide

#### Triple Tube Assemblies (Primary tube is 3/8"; middle tube is 11/16")

23 - 3/8" High temperature Mullite

29 - 3/8" Aluminum oxide

### Field 7. COLD END TERMINATION

See page 3-30 for protection tube/cold end termination compatibility table.

- 1 - General purpose, cast iron, Obsolete use code "2"
- 2 - Weatherproof, cast iron
- 3 - General purpose, aluminum, Obsolete use code "A"
- 9 - Brass, open, no external process mount threads
- A - Weatherproof, aluminum
- C - Brass, open, with external process mount threads
- D - Aluminum, DIN size

### Fields 8, 9. HOT LENGTH (DIMENSION "HL")

 Complete these Fields to determine lengths for Fields 1, 2, 3 and Fields 5, 6

HL - Enter actual inches in 6" increments. Minimum 12", maximum 48"

Over 48" consult factory for availability.

### Field 10. OUTER TUBE

Priced in Fields 5, 6

- 2 - Dual tube assembly, silicone carbide outer tube
- 3 - Triple tube assembly, silicone carbide outer tube

### Field 11. TUBE SEAL

- 0 - None
- 1 - Sealed and filled with inert gas

### Field 12. RESERVED

### Field 13. MOUNTING FITTING

- 0 - None
- 2 - Adjustable mounting flange

### Fields 14, 15. RESERVED

# Fluoroplastic Coated

## Fluoroplastic Coated Stainless Steel Tube, Straight for Chemical and Acids

### Introduction

This thermocouple is suggested for pickling baths, and chemical and acid vats. It consists of a 20 gauge element inside .188" o.d. Teflon FEP coated tube. Teflon FEP is resistant to most acids and bases, dry fluorine at 300°F, molten sodium hydroxide, and steam up to 450°F. Among the organics, nearly complete resistance is shown to aliphatics, aromatics, alcohol, acids, and chlorinated solvents.

### Ordering Information

**Model No.**  I - 7 4 0  -  -  -   
Field No. 1 2 3 4 5 6 7 8 9 10 11 12 13 14 15

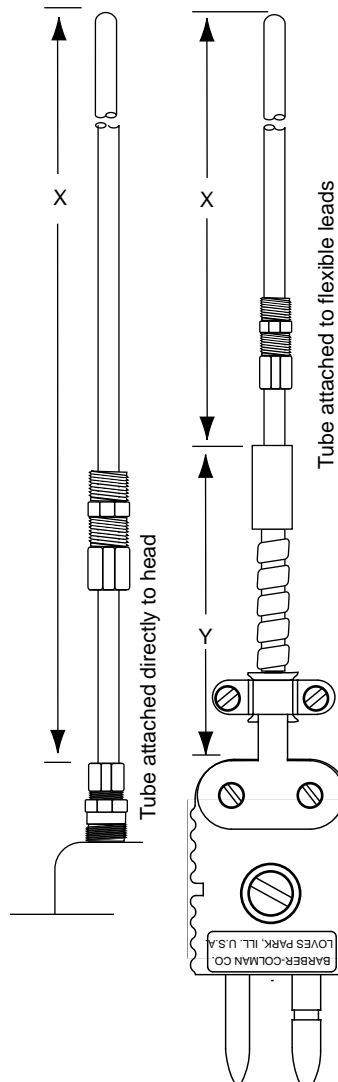

#### Fields 1, 2, 3. THERMOCOUPLE TYPE, GAUGE, LIMITS

☞ Determine length by completing Fields 8, 9

Type	Wire	Gauge	Limits
J20 - J	Iron-Constantan	20	standard
J21 - J	Iron-Constantan	20	special
K20 - K	Chromel-Alumel	20	standard
K21 - K	Chromel-Alumel	20	special
E20 - E	Chromel-Constantan	20	standard
E21 - E	Chromel-Constantan	20	special
T20 - T	Copper-Constantan	20	standard
T21 - T	Copper-Constantan	20	special
N20 - N	Nicrosil-Nisil	20	standard

#### Fields 4 through 6. RESERVED

#### Field 7. FLEXIBLE LEADWIRE CONSTRUCTION

- 0 - No Flexible leads
- A - Flexible armor
- B - Flexible armor with PVC sleeving
- C - Flexible armor with Teflon sleeving

#### Fields 8, 9. RIGID LENGTH ("X" DIMENSION)

XX - Specify in whole inches. Maximum standard length: 48"

#### Fields 10, 11, 12. FLEXIBLE LENGTH ("Y" DIMENSION)

- 000 - None
- YYY - Specify in whole inches. Maximum length: 240"

#### Field 13. MOUNTING FITTINGS

- 0 - None
- A - 316 SS body, 316 SS ferrule, 1/8" NPT
- B - 316 SS body, Teflon ferrule, 1/8" NPT
- C - Teflon Body, Teflon ferrule, 1/8" NPT

# Fluoroplastic Coated

## Fields 14, 15. COLD END TERMINATION

- 00 - 2-1/2" stripped leads
- 01 - 2-1/2" leads with spade lugs
- 02 - 2-1/2" leads with spade lugs and box connector
- 03 - Quick disconnect plug
- 04 - Quick disconnect plug and jack
- 05 - Ceramic wafer open head
- 06 - Miniature head and cover
- 07 - Quick disconnect jack
- 08 - General purpose, cast iron head, Obsolete use code "10"
- 09 - General purpose, aluminum head, Obsolete use code "27"
- 10 - Weatherproof, cast iron head
- 12 - Weatherproof, plastic head
- 27 - Weatherproof, aluminum head

# Case Hardened Steel

## Case Hardened Steel Pipe, Straight for Aggregate and Granular Materials

### Introduction

This assembly is particularly suited to measuring temperature of asphalt and other granular materials such as grain, sand, gravel, and pulverized coal. The element is solid 14 gauge with porcelain insulation inside a 1/4" NPT seamless steel case hardened protection pipe. The end of the pipe is cut at an angle to protect the element and allow close contact with the material. The tip of the thermocouple with grounded junction style is welded to the end of the pipe for greater sensitivity.

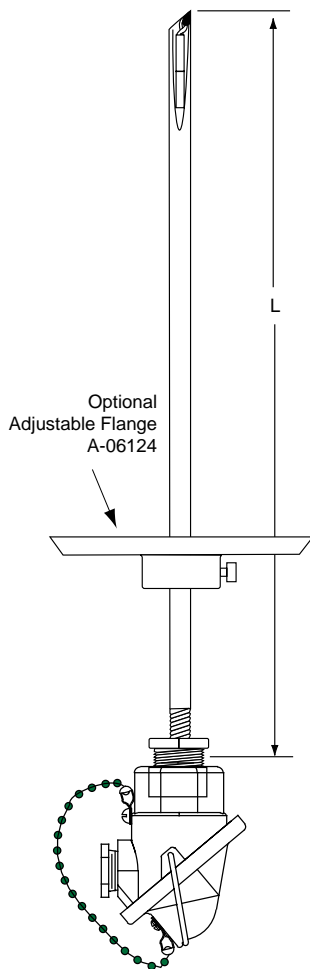

**Model No.**  **A** -  -  -  -

Field No.      1   2   3   4      5   6   7   8   9      10 11 12   13   14 15

- Fields 1 through 4 : Indicates assembly (leading zeros dropped)
- Fields 5 through 9: Type of head
- Fields 10 through 12: Calibration (Type J or Type K)
- Field 13: Junction style (grounded, ungrounded)
- Fields 14, 15: "L" dimension in inches. Maximum 48".

Model	Type	Style	Head
A-11266-100-0-LL	J	Grounded	Gen Purpose, Cast Iron, (Obsolete)
A-11266-100-1-LL	J	Ungrounded	Gen Purpose, Cast Iron, (Obsolete)
A-11266-200-0-LL	K	Grounded	Gen Purpose, Cast Iron, (Obsolete)
A-11266-200-1-LL	K	Ungrounded	Gen Purpose, Cast Iron, (Obsolete)
A-11568-100-0-LL	J	Grounded	Weatherproof, Cast Iron
A-11568-100-1-LL	J	Ungrounded	Weatherproof, Cast Iron
A-11568-200-0-LL	K	Grounded	Weatherproof, Cast Iron
A-11568-200-1-LL	K	Ungrounded	Weatherproof, Cast Iron
A-11569-100-0-LL	J	Grounded	Aluminum, Cast Iron, (Obsolete)
A-11569-100-1-LL	J	Ungrounded	Aluminum, Cast Iron, (Obsolete)
A-11569-200-0-LL	K	Grounded	Aluminum, Cast Iron, (Obsolete)
A-11569-200-1-LL	K	Ungrounded	Aluminum, Cast Iron, (Obsolete)

### Replacement Protection Tube

- A-11657-100-HL    J    with grounded element
- A-11657-200-HL    K    with grounded element
- 0042-07300-300-0-XX    tube only

# Diesel Engine

## Detachable Diesel Engine Thermocouples

### Introduction

#### Rigid Type

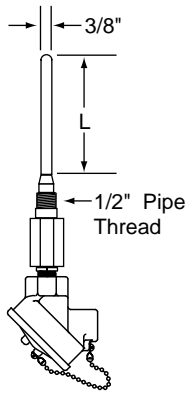

The rigid detachable type is of rugged construction to withstand vibration. The element can be easily removed for inspection or replacement: Remove the cover from the weatherproof head and disconnect the lead wires. Then pull the terminal block and insulated element from the assembly.

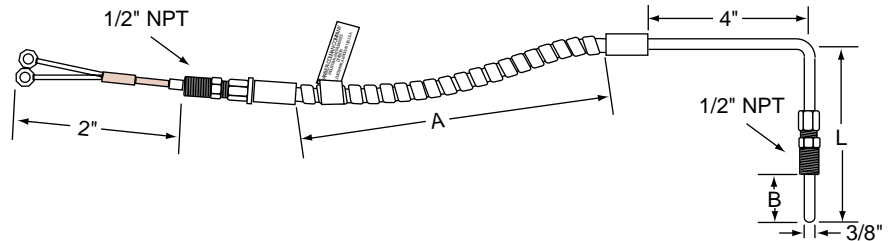

#### Flexible Type

Flexible armor protection of thermocouple leads allows easy connection to remotely located cold end terminal board.

### Specifications

#### Rigid Type

Wire: Type J (Iron-Constantan), 20 gauge  
 Insulation: Two hole ceramic  
 Head: Cast iron weatherproof with screw on cover  
 Well: Seamless steel tubing and fitting – welded  
 Conduit Coupling: Weatherproof – standard  
 Temperature Limit: 1000°F recommended maximum  
 Finish: Flat black lacquer painted

#### Flexible Type

Wire: Type J (Iron-Constantan), 20 gauge  
 Insulation: Double glass wrap with overall glass braid. Ceramic bead (fish spine) insulators at head.  
 Protection Tube: 3/8" o.d. x 0.245" i.d. seamless steel tubing and 1/4" i.d. Greenfield flexible tubing  
 Connector: 2" split leads silver brazed to terminal nuts.  
 Temperature Limit: 900°F recommended maximum  
 Immersion Length:

<u>Length "L"</u>	<u>Maximum Immersion Length "B"</u>
4"	1/2"
5"	1-1/2"
6"	2-1/2"
7	3-1/2"
8	4-1/2"
9	5-1/2"
11	7-1/2"
13	9-1/2"
20	16-1/2"

# Diesel Engine

## Ordering Information

**Model No. E N 0  - J 0    -    - 0 - 0 0**  
Field No.      1 2 3 4    5 6 7 8 9    10 11 12    13 14 15

**Fields 1, 2, 3, 4. BASE MODEL**

EN01 - Rigid Style  
EN02 - Flexible Style

**Fields 5, 6. RESERVED**

**Fields 7, 8, 9. TUBE LENGTH (DIMENSION "L")**

030 - 3"  
070 - 7"  
110 - 11"  
150 - 15"  
190 - 19"

Note: see immersion length "B" of EN02 in "Specifications" section

**Fields 10, 11, 12. FLEXIBLE LENGTH (DIMENSION "A")**

000 - Not applicable (Model EN01)  
AAA - Length in whole inches (example: 006 = 6"; 019 = 19")

**Fields 13, 14, 15. RESERVED**

# Pad Style

## Pad Style (MgO) Thermocouple

### Introduction

Specifically designed for mounting to pipe. Several pads available to accommodate various pipe diameters.

### Ordering Information

**Model No.** M  3 6 -  0    - B   -  -    
Field No. 1 2 3 4 5 6 7 8 9 10 11 12 13 14 15

#### Fields 1, 2, 3, 4. BASE MODEL

☞ To determine length, complete fields 7, 8, 9

MJ36 - Type J, special limits, 0.250" 316 SS sheath  
MK36 - Type K, special limits, 0.250" 316 SS sheath

#### Field 5. JUNCTION STYLE

- 1 - Single element, grounded
- 2 - Single element, ungrounded

#### Field 6. RESERVED

#### Fields 7, 8, 9. LENGTH

- XXX - Actual length in whole inches
- 999 - Longer than 998" (Consult Factory)

#### Field 10. RESERVED

#### Field 11. PAD STYLE

- A - Horizontal
- B - Vertical

#### Field 12. PAD RADIUS

- A - Flat
- B - 0.435" (1/2" pipe)
- C - 0.515" (3/4" pipe)
- D - 0.670" (1" pipe)
- E - 1.205" (2" pipe)
- F - 1.765" (3" pipe)
- G - 2.265" (4" pipe)

#### Field 13. ATTACHING DEVICE

- 0 - None
- A - 1/2" NPT nipple with compression fitting
- B - Union with 1/2" NPT nipples with compression fitting

#### Fields 14, 15. COLD END TERMINATION

- 10 - Cast iron weatherproof head
- 27 - Aluminum weatherproof head

#### ACCESSORIES

13-4661 304 SS welding strap for 1/4" sheath

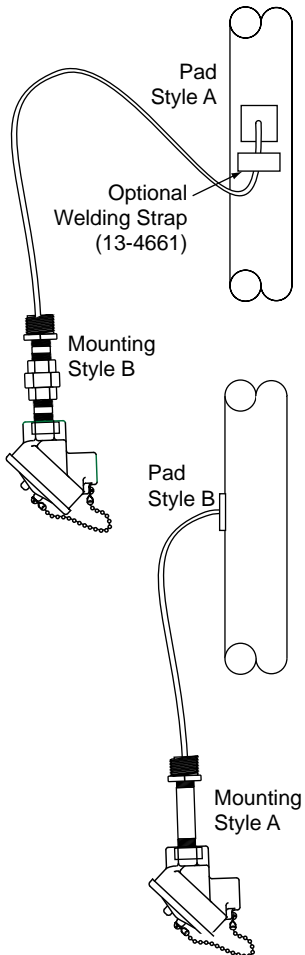

# Furnace Survey

## Base Metal Thermocouple Wire with Junction and Cold End Termination for Furnace Survey

### Introduction

This thermocouple consists of insulated wire with twisted and welded junction, and your choice of cold end termination.

### Ordering Information

**Model No. W**  -  - **000** -  -   
Field No. 1 2 3 4 5 6 7 8 9 10 11 12 13 14 15

#### Field 1. BASE MODEL

W - Base Metal Wire

#### Fields 2 through 9. WIRE SPECIFICATIONS AND INSULATION

 To determine length (required for pricing), complete Fields 14, 15. Obtain codes for Fields 2 through 9 from "T/C and Extension Wire" listing (base metal, insulated duplex only) in the "Wire and Accessories" section of this document, then return here to complete the model number.

#### Fields 10, 11, 12. RESERVED

#### Field 13. COLD END TERMINATION

- 1 - Stripped leads
- 2 - Lugs
- 5 - Solid pin quick disconnect plug
- 6 - Quick disconnect jack

#### Fields 14, 15. ASSEMBLY LENGTH

-  Complete these fields to determine length for Fields 2 through 9
- XX - Length (in whole inches) of prepared wire, up to 98"  
(examples: 035 = 3-1/2"; 190 = 19")
  - 99 - Longer than 98". Specify on order.

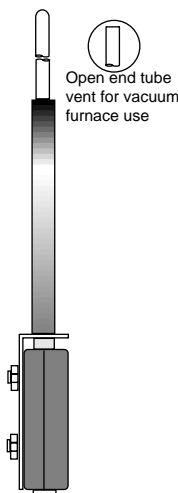

## Noble Metal Assemblies for Vacuum Furnace Operation

Type C (Tungsten, 5% Rhenium-Tungsten, 26% Rhenium) thermocouples can be used in temperatures up to 3400°F. Element must operate either in a vacuum or in an inert gas. In this assembly, a choice of protection tube seal allows the furnace atmosphere to become the protective atmosphere, or the unit can be provided with thermocouple sealed and backfilled with Argon for protection against external environment. Recommended for use up to 2900°F mounted horizontally, or 3400°F mounted vertically.

Open end tube is designed for a furnace in which the process cycle is such that the furnace is at low vacuum or inert before the temperature is increased, and the vacuum is maintained until the furnace temperature is cooled below 200°F.

Note: "1" (C24I) is the letter "I," not the numeral "1."

C24I-297HL-010-3-00 Sealed and filled with inert gas  
C24I-297HL-020-3-00 Sealed and vented to furnace

## Resistance Temperature Detector, Platinum

### Introduction

RTDs change resistance with temperature changes. They are more accurate than thermocouples, especially over a narrow range. Standard accuracy ratings of 0.25% and 0.10% are offered. However, they offer less resistance to physical shock, and respond slower.

The RTD element is a wire coil precision wound to a specific resistance value, hermetically sealed to prevent influence from moisture. It is mounted in the tip of a metal protection tube for physical protection

### Ordering Information

**Model No. R**    -      -    -  -

Field No.            1   2   3   4        5   6   7   8   9        10 11 12    13    14 15

#### Fields 1, 2, 3. BASE MODEL

Determine length by completing Fields 8, 9 and Fields 10, 11, 12, then add together.

Description	Accuracy	Temperature Rating
R51 - 0.00391 $\Omega/\Omega/^\circ\text{C}$	0.25%	500°F (Teflon)
R52 - 0.00391 $\Omega/\Omega/^\circ\text{C}$	0.10%	500°F (Teflon)
R53 - 0.00391 $\Omega/\Omega/^\circ\text{C}$	0.25%	932°F (Fiberglass)
R54 - 0.00391 $\Omega/\Omega/^\circ\text{C}$	0.10%	932°F (Fiberglass)
R71 - 0.00385 $\Omega/\Omega/^\circ\text{C}$	0.25%	500°F (Teflon)
R72 - 0.00385 $\Omega/\Omega/^\circ\text{C}$	0.10%	500°F (Teflon)
R73 - 0.00385 $\Omega/\Omega/^\circ\text{C}$	0.25%	932°F (Fiberglass)
R74 - 0.00385 $\Omega/\Omega/^\circ\text{C}$	0.10%	932°F (Fiberglass)

#### Field 4. NUMBER OF ELEMENTS AND WIRES

See compatibility table after Fields 14, 15

- 1 - Single element, 3 wire
- 2 - Dual element, 3 wire (Requires 0.250" protection tube, Fields 5, 6)
- 5 - Single element, 4 wire

#### Fields 5, 6. PROTECTION TUBE

Use length determined in Fields 8, 9

Size	Material
65 - 0.188" o.d.	304 stainless steel
66 - 0.250" o.d.	304 stainless steel
68 - 0.188" o.d.	316 stainless steel
69 - 0.250" o.d.	316 stainless steel
72 - 0.250" o.d.	Inconel

#### Field 7. FLEXIBLE LEAD MATERIAL

Use length determined in Fields 10, 11, 12. See compatibility table after Field 15. (If fields 10, 11 & 12 equal "000" and fields 14 & 15 equal "00", "01" or "02", then field 7 must be code "1". Six inch leads will be supplied.)

- 0 - None
- 1 - Teflon (500°F) or Fiberglass (932°)
- 2 - Teflon (500°F) or Fiberglass (932°) with armor
- 3 - Teflon (500°F) or Fiberglass (932°) with SS overbraid (avail. only if Field 4 is "1")

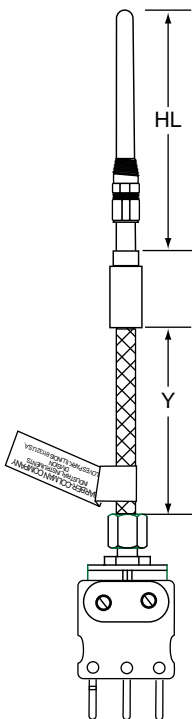

## Ordering Information (continued)

### Fields 8, 9. HOT LENGTH (DIMENSION "HL")

- ☞ Complete these Fields to determine lengths for Fields 1, 2, 3, and Fields 5, 6
- HL - Actual length in whole inches; minimum 3"
- 99 - Longer than 98". Specify details on order

### Fields 10, 11, 12. FLEXIBLE LEAD LENGTH (DIMENSION "Y")

- ☞ Complete these Fields to determine lengths for Fields 1, 2, 3, and Field 7
- 000 - None - no flexible lead (Note 1)
- YYY- Actual length in whole inches
- 999 - Longer than 998". Specify details on order

### Field 13. MOUNTING FITTING

- 0 - None
- 4 - 1/4" NPT nickel plated brass compression fitting
- 5 - 1/4" NPT stainless steel compression fitting
- 7 - Stainless steel double ended bushing, 1/2" NPT only
- 8 - Spring loaded stainless steel double ended bushing, 1/2" NPT only
- 9 - Specify details on order

### Fields 14, 15. COLD END TERMINATION

See page 3-24 for protection tube/cold end termination compatibility table.  
See compatibility table below

- 00 - 2-1/2" split leads, ends stripped (Note 1)
- 01 - 2-1/2" split leads, spade lugs (Note 1)
- 02 - 2-1/2" split leads, spade lugs, 1/2" NPS box connector with lock nut (Note 1)
- 03 - Solid pin quick disconnect plug
- 04 - Solid pin quick disconnect plug with mating jack
- 05 - Ceramic wafer open head
- 06 - Miniature head and cover
- 08 - General purpose, cast iron head, Obsolete use code "10"
- 09 - General purpose, aluminum head, Obsolete use cose "27"
- 10 - Weatherproof, cast iron head
- 12 - Weatherproof, plastic head
- 27 - Weatherproof, aluminum head
- 21 - Amphenol connector
- 22 - Explosionproof head
- 30 - Single ended 1/4" NPT hex bushing, 6" leads
- 32 - Aluminum, DIN size

Compatibility Table. Blank cell = compatible; filled cell = not compatible																
Fields 14, 15	00	01	02	03	04	05	06	08	09	10	12	27	21	22	30	32
Field 4, Code 1																
Field 4, Code 2																
Field 4, Code 5																
Field 4, Code 4																
Field 7, Code 0																
Field 7, Code 1																
Field 7, Code 2																
Field 7, Code 3																

Note 1, If fields 10, 11, and 12 equal "000" and fields 14 & 15 equal "00", "01" or "02", then field 7 must be code "1". Six inch leads will be supplied.

# Protection Tube/Head Compatibility

This table shows which heads are compatible with each protection tube for industrial sensors. Blank cell = compatible; filled cell = not compatible.

See Section 6 for head descriptions.

Head Model Number:		HD01	HD03	HD04	HD05	HD06	HD08	HD09	HD11	HD12	HD14	HD15	HD16	HD17
Fields 5, 6. Protection Tube		Field 7. Cold End Termination Codes												
Code / Description		1	3	4	5	6	8	8	B	A	9	C	E	D
01	Cast iron coated													
02	Black steel, 1/4" NPS													
03	Black steel, 1/2" NPS													
04	Black steel, 3/4" NPS													
05	Black steel, 1" NPS													
06	Welded steel, 1/8" NPS													
07	Welded steel, 1/4" NPS													
08	Welded steel, 1" NPS													
09	Cast iron													
11	446 SS, 3/4" NPS													
12	446 SS, 1/2" NPS													
13	446 SS, 1" NPS													
14	Pure nickel, 1/2" NPS													
16	Inconel 601, 1/2" NPS													
17	Inconel 601, 3/4" NPS													
18	304 SS, 1/4" NPS													
19	304 SS, 1/2" NPS													
21	Silicon carbide, 1-3/4" o.d.													
22	Silicon carbide w/collar													
23	H.T. Mullite, 3/8" o.d.													
24	H.T. Mullite, 11/16" o.d.													
25	H.T. Mullite, 1" o.d.													
26	Incoloy 800, 1/2" NPS													
27	Incoloy 800, 3/4" NPS													
28	Metal ceramic, 7/8" o.d.													
29	Aluminum oxide, 3/8" o.d.													
30	Aluminum oxide, 11/16" o.d.													
31	Aluminum oxide, 1" o.d.													
41	Ceramic clad													
42	Ceramic clad w/spring													
44	316 SS, 1/2" NPS													
46	Silicon carbide pipe, reinforced													
47	316 SS, 3/4" NPS													
65	304 SS, 0.160" x 0.185"													
66	304 SS, 0.194" x 0.250"													
67	304 SS, 0.305" x 0.375"													
68	316 SS, 0.160" x 0.185"													
69	316 SS, 0.194" x 0.250"													
70	316 SS, 0.305" x 0.375"													
72	Inconel 601, 0.194" x 0.250"													
73	Inconel 601, 0.305" x 0.375"													